

INTRODUCTION

S6A0075 is a dot matrix LCD driver & controller LSI which is fabricated by low power CMOS technology. It can display 1, 2, or 4 lines with 5 x 8 or 6 x 8 dots format.

FUNCTIONS

- Character type dot matrix LCD driver & controller
- Internal driver: 34 common and 100 segment signal output
- Easy interface with 4-bit or 8-bit MPU
- Clock synchronized serial interface
- 5 x 8 dot matrix/6 x 8 dot matrix possible
- Bi-directional shift function
- All character reverse display
- Display shift per line
- Voltage converter for LCD drive voltage: 13V max. (2 times/3 times)
- Various instruction functions
- Automatic power on reset

FEATURES

- Internal memory
 - Character Generator ROM (CGROM): 9,600 bits (240 characters x 5 x 8 dot)
 - Character Generator RAM (CGRAM): 64 x 8 bits (8 characters x 5 x 8 dot)
 - Segment Icon RAM (SEGRAM): 16 x 8 bits (96 icons max.)
 - Display Data RAM (DDRAM): 80 x 8 bits (80 characters max.)
- Low power operation
 - Power supply voltage range: 2.7 - 5.5V (V_{DD})
 - LCD Drive voltage range: 3.0 - 13.0V (V_{DD} - V_5)
- CMOS process
- Programmable duty cycle: 1/17, 1/33
- Internal oscillator with an external resistor
- Bare chip available

PROGRAMMABLE DUTY CYCLES

5-dot Font Width

Display Line Numbers	Duty Ratio	Single-chip Operation	
		Displayable Characters	Possible Icons
1	1/17	1 line of 40 characters	80
2	1/33	2 lines of 40 characters	80
4	1/33	4 lines of 20 characters	80

6-dot Font Width

Display Line Numbers	Duty Ratio	Single-chip Operation	
		Displayable Characters	Possible Icons
1	1/17	1 line of 32 characters	96
2	1/33	2 lines of 32 characters	96
4	1/33	4 lines of 16 characters	96

BLOCK DIAGRAM

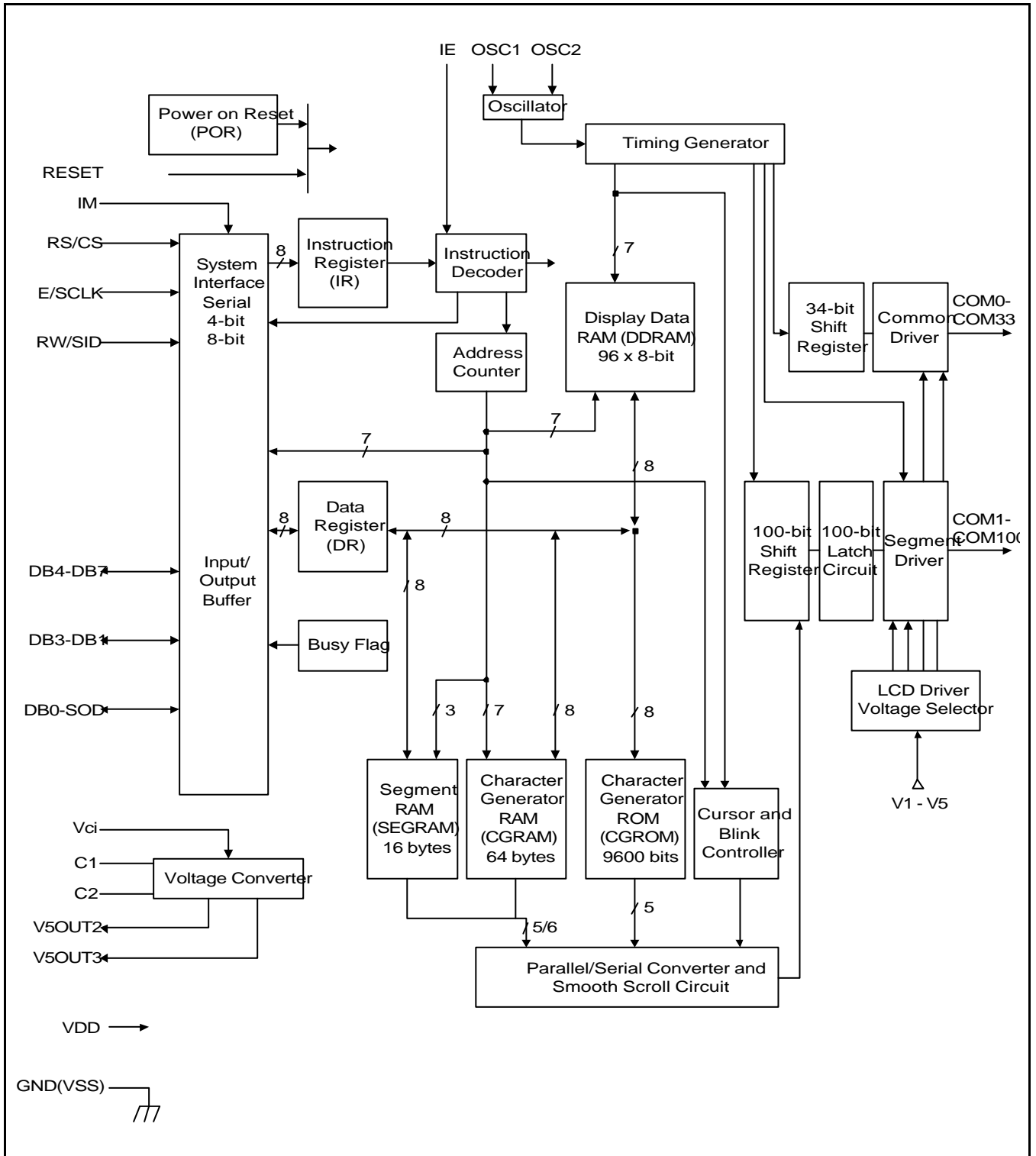

PAD CENTER COORDINATES

Table 1. Pad Location

Pad No.	Pad Name	Coordinate		Pad No.	Pad Name	Coordinate		Pad No.	Pad Name	Coordinate	
		X	Y			X	Y			X	Y
1	SEG68	-2975	-2504	33	SEG100	1024	-2504	65	DB4	3559	0
2	SEG69	-2850	-2504	34	COM9	1262	-2504	66	DB5	3559	125
3	SEG70	-2725	-2504	35	COM10	1387	-2504	67	DB6	3559	250
4	SEG71	-2600	-2504	36	COM11	1512	-2504	68	DB7	3559	375
5	SEG72	-2475	-2504	37	COM12	1637	-2504	69	VCI	3559	500
6	SEG73	-2350	-2504	38	COM13	1762	-2504	70	C2	3559	625
7	SEG74	-2225	-2504	39	COM14	1887	-2504	71	C1	3559	750
8	SEG75	-2100	-2504	40	COM15	2012	-2504	72	VSS2	3559	875
9	SEG76	-1975	-2504	41	COM16	2137	-2504	73	V5OUT2	3559	1000
10	SEG77	-1850	-2504	42	COM25	2262	-2504	74	V5OUT3	3559	1125
11	SEG78	-1725	-2504	43	COM26	2387	-2504	75	V5	3559	1250
12	SEG79	-1600	-2504	44	COM27	2512	-2504	76	V4	3559	1375
13	SEG80	-1475	-2504	45	COM28	2637	-2504	77	V3	3559	1500
14	SEG81	-1350	-2504	46	COM29	2762	-2504	78	V2	3559	1625
15	SEG82	-1225	-2504	47	COM30	2887	-2504	79	V1	3559	1750
16	SEG83	-1100	-2504	48	COM31	3012	-2504	80	COM24	3262	2504
17	SEG84	-975	-2504	49	COM32	3137	-2504	81	COM23	3137	2504
18	SEG85	-850	-2504	50	COM33	3262	-2504	82	COM22	3012	2504
19	SEG86	-725	-2504	51	VDD	3559	-1750	83	COM21	2887	2504
20	SEG87	-600	-2504	52	OSCC	3559	-1625	84	COM20	2762	2504
21	SEG88	-475	-2504	53	OSC1	3559	-1500	85	COM19	2637	2504
22	SEG89	-350	-2504	54	RESET	3559	-1375	86	COM18	2512	2504
23	SEG90	-225	-2504	55	IM	3559	-1250	87	COM17	2387	2504
24	SEG91	-100	-2504	56	IE	3559	-1125	88	COM8	2262	2504
25	SEG92	24	-2504	57	VSS1	3559	-1000	89	COM7	2137	2504
26	SEG93	149	-2504	58	RS/CS	3559	-875	90	COM6	2012	2504
27	SEG94	274	-2504	59	RW/SID	3559	-750	91	COM5	1887	2504
28	SEG95	399	-2504	60	E/SCLK	3559	-625	92	COM4	1762	2504
29	SEG96	524	-2504	61	DB0/SOD	3559	-500	93	COM3	1637	2504
30	SEG97	649	-2504	62	DB1	3559	-375	94	COM2	1512	2504
31	SEG98	774	-2504	63	DB2	3559	-250	95	COM1	1387	2504
32	SEG99	899	-2504	64	DB3	3559	-125	96	COM0	1262	2504

Table 1. Pad Location (Continued)

Pad No.	Pad Name	Coordinate		Pad No.	Pad Name	Coordinate		Pad No.	Pad Name	Coordinate	
		X	Y			X	Y			X	Y
97	SEG1	1024	2504	120	SEG24	-1850	2504	143	SEG47	-3559	437
98	SEG2	899	2504	121	SEG25	-1975	2504	144	SEG48	-3559	312
99	SEG3	774	2504	122	SEG26	-2100	2504	145	SEG49	-3559	187
100	SEG4	649	2504	123	SEG27	-2225	2504	146	SEG50	-3559	62
101	SEG5	524	2504	124	SEG28	-2350	2504	147	SEG51	-3559	-62
102	SEG6	399	2504	125	SEG29	-2475	2504	148	SEG52	-3559	-187
103	SEG7	274	2504	126	SEG30	-2600	2504	149	SEG53	-3559	-312
104	SEG8	149	2504	127	SEG31	-2725	2504	150	SEG54	-3559	-437
105	SEG9	24	2504	128	SEG32	-2850	2504	151	SEG55	-3559	-562
106	SEG10	-100	2504	129	SEG33	-2975	2504	152	SEG56	-3559	-687
107	SEG11	-225	2504	130	SEG34	-3559	2062	153	SEG57	-3559	-812
108	SEG12	-350	2504	131	SEG35	-3559	1937	154	SEG58	-3559	-937
109	SEG13	-475	2504	132	SEG36	-3559	1812	155	SEG59	-3559	-1062
110	SEG14	-600	2504	133	SEG37	-3559	1687	156	SEG60	-3559	-1187
111	SEG15	-725	2504	134	SEG38	-3559	1562	157	SEG61	-3559	-1312
112	SEG16	-850	2504	135	SEG39	-3559	1437	158	SEG62	-3559	-1437
113	SEG17	-975	2504	136	SEG40	-3559	1312	159	SEG63	-3559	-1562
114	SEG18	-1100	2504	137	SEG41	-3559	1187	160	SEG64	-3559	-1687
115	SEG19	-1225	2504	138	SEG42	-3559	1062	161	SEG65	-3559	-1812
116	SEG20	-1350	2504	139	SEG43	-3559	937	162	SEG66	-3559	-1937
117	SEG21	-1475	2504	140	SEG44	-3559	812	163	SEG67	-3559	-2062
118	SEG22	-1600	2504	141	SEG45	-3559	687				
119	SEG23	-1725	2504	142	SEG46	-3559	562				

PAD DESCRIPTION

Table 2. Pad Description

Pad (No)	Input/Output	Name	Description	Interface
VDD (51)	-	Power supply	for logical circuit (+3V, +5V)	Power supply
VSS1, VSS2 (57,72)			0V (GND)	
V1 - V5 (79 - 75)			Bias voltage level for LCD driving.	
Vci (69)			Input voltage to the voltage converter to generate LCD drive voltage (Vci = 2.5 - 4.5V).	
SEG1 - SEG100 (97- 33)	Output	Segment output	Segment signal output for LCD drive.	LCD
COM0 - COM33 (80 - 96, 34 - 50)	Output	Common output	Common signal output for LCD drive.	LCD
OSC1, OSC2 (53, 52)	Input (OSC1), Output (OSC2)	Oscillator	When use internal oscillator, connect external Rf resistor. If external clock is used, connect it to OSC1.	External resistor/oscillator(OSC1)
C1, C2 (71, 70)	Input	External capacitance input	To use the voltage converter (2 times /3 times), these pins must be connected to the external capacitance.	External capacitance
RESET (54)	Input	Reset pin	Initialized to low	-
IE (56)	Input	Select pin of instruction set	When IE = "High", Instruction set is selected as Table 6. When IE = "Low", Instruction set is selected as Table 10.	-
V5OUT2 (73)	Output	Two times converter output	The value of Vci is converted two times. To use three times converter, the same capacitance as that of C1-C2 should be connected here.	V5 capacitance
V5OUT3 (74)		Three times converter output	The value of Vci is converted three times.	V5
IM (55)	Input	Interface mode selection	Select Interface mode with the MPU. When IM = "Low": Serial mode, When IM = "High": 4-bit/8-bit bus mode.	-

Table 2. Pad Description (Continued)

Pad (No)	Input/Output	Name	Description	Interface
RS/CS (58)	Input	Register select/ chip select	When bus mode, used as register selection input. When RS/CS = "High", data register is selected. When RS/CS = "Low", instruction register is selected. When serial mode, used as chip selection input. When RS/CS = "Low", selected. When RS/CS = "High", not elected. (low access enable)	MPU
RW/SID (59)	Input	Read/Write/ Serial input data	When bus mode, used as read/write election input. When RW/SID = "High", read operation. When RW/SID = "Low", write operation. When serial mode, used for data input pin.	MPU
E/SCLK (60)	Input	Read/Write Enable/Serial clock	When bus mode, used as read/write enable signal. When serial mode, used as serial clock input pin.	MPU
DB0/SOD (61)	Input.Output/ Output	Data bus 0 bit/serial output data	When 8-bit bus mode, used as lowest bi-directional data bit. During 4-bit bus mode, open this pin. When serial mode, used as serial data output pin. If not in read operation, open this pin.	MPU
DB1 - DB3 (62 - 64)	Input.Output	Data bus 1-7	When 8-bit bus mode, used as low order bi-directional data bus. During 4-bit bus mode or serial mode, open these pins.	MPU
DB4 - DB7 (65 - 68)			When 8-bit bus mode, used as high order bi-directional data bus. In case of 4-bit bus mode, used as both high and low order. DB7 used for busy flag output. During serial mode, open these pins.	MPU

FUNCTION DESCRIPTION

SYSTEM INTERFACE

This chip has all three kinds interface type with MPU: serial, 4-bit bus and 8-bit bus. Serial and bus (4-bit/8-bit) is selected by IM input, and 4-bit bus and 8-bit bus is selected by DL bit in the instruction register. During read or write operation, two 8-bit registers are used. one is data register (DR), the other is instruction register (IR). The data register (DR) is used as temporary data storage place for being written into or read from DDRAM/CGRAM/SEGRAM, target RAM is selected by RAM address setting instruction. Each internal operation, reading from or writing into RAM, is done automatically. So to speak, after MPU reads DR data, the data in the next DDRAM/CGRAM/SEGRAM address is transferred into DR automatically. Also after MPU writes data to DR, the data in DR is transferred into DDRAM/CGRAM/SEGRAM automatically. The Instruction register (IR) is used only to store instruction code transferred from MPU. MPU cannot use it to read instruction data. To select register, use RS/CS input pin in 4-bit/8-bit bus mode (IM = "High") or RS bit in serial mode (IM = "Low").

RS	R/W	Operation
0	0	Instruction write operation (MPU writes Instruction code into IR)
0	1	Read busy flag (DB7) and address counter (DB0 – DB6)
1	0	Data write operation (MPU writes data into DR)
1	1	Data read operation (MPU reads data from DR)

BUSY FLAG (BF)

When BF = "High", it indicates that the internal operation is being processed. So during this time the next instruction cannot be accepted. BF can be read, when RS = Low and R/W = High (Read Instruction Operation), through DB7. Before executing the next instruction, be sure that BF is not high.

DISPLAY DATA RAM (DDRAM)

DDRAM stores display data of maximum 80 x 8 bits (80 characters). DDRAM address is set in the address counter (AC) as a hexadecimal number. (refer to Figure 1.)

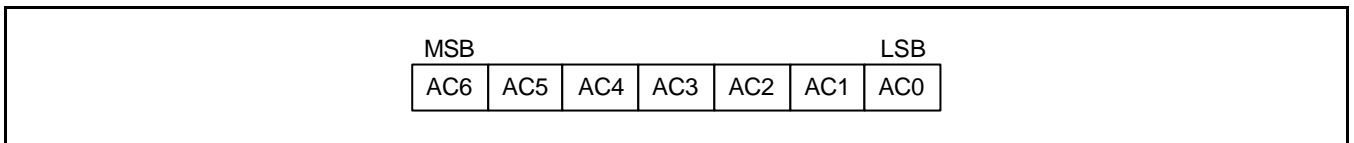

Figure 1. DDRAM Address

Display of 5-Dot Font Width Character

5-dot 1-line Display

In case of 1-line display with 5-dot font, the address range of DDRAM is 00H-4FH. (refer to Figure 2)

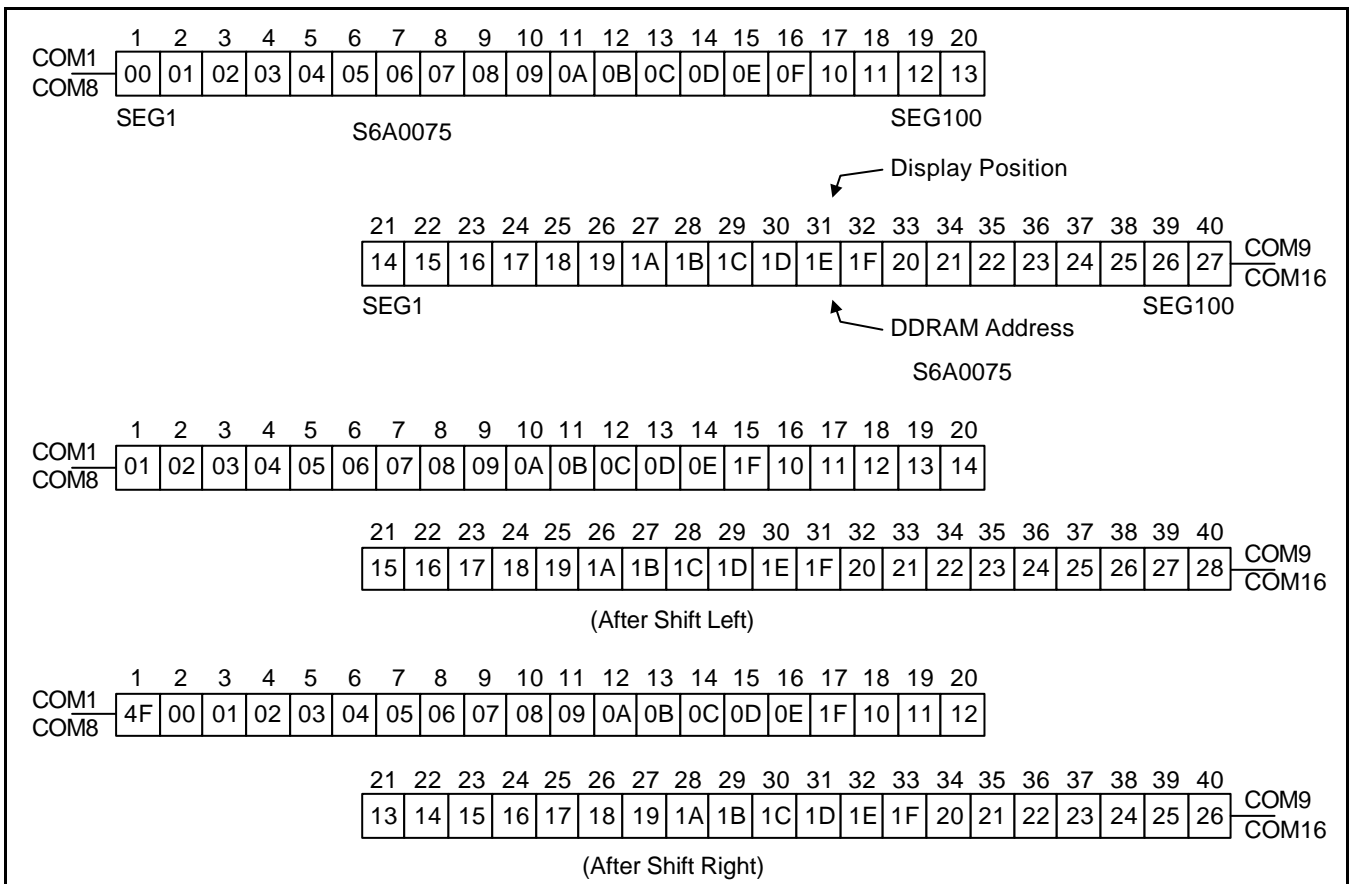

Figure 2. 1-line x 40ch. Display

5-dot 2-line Display

In case of 2-line display with 5-dot font, the address range of DDRAM is 00H-27H, 40H-67H (refer to Figure 3).

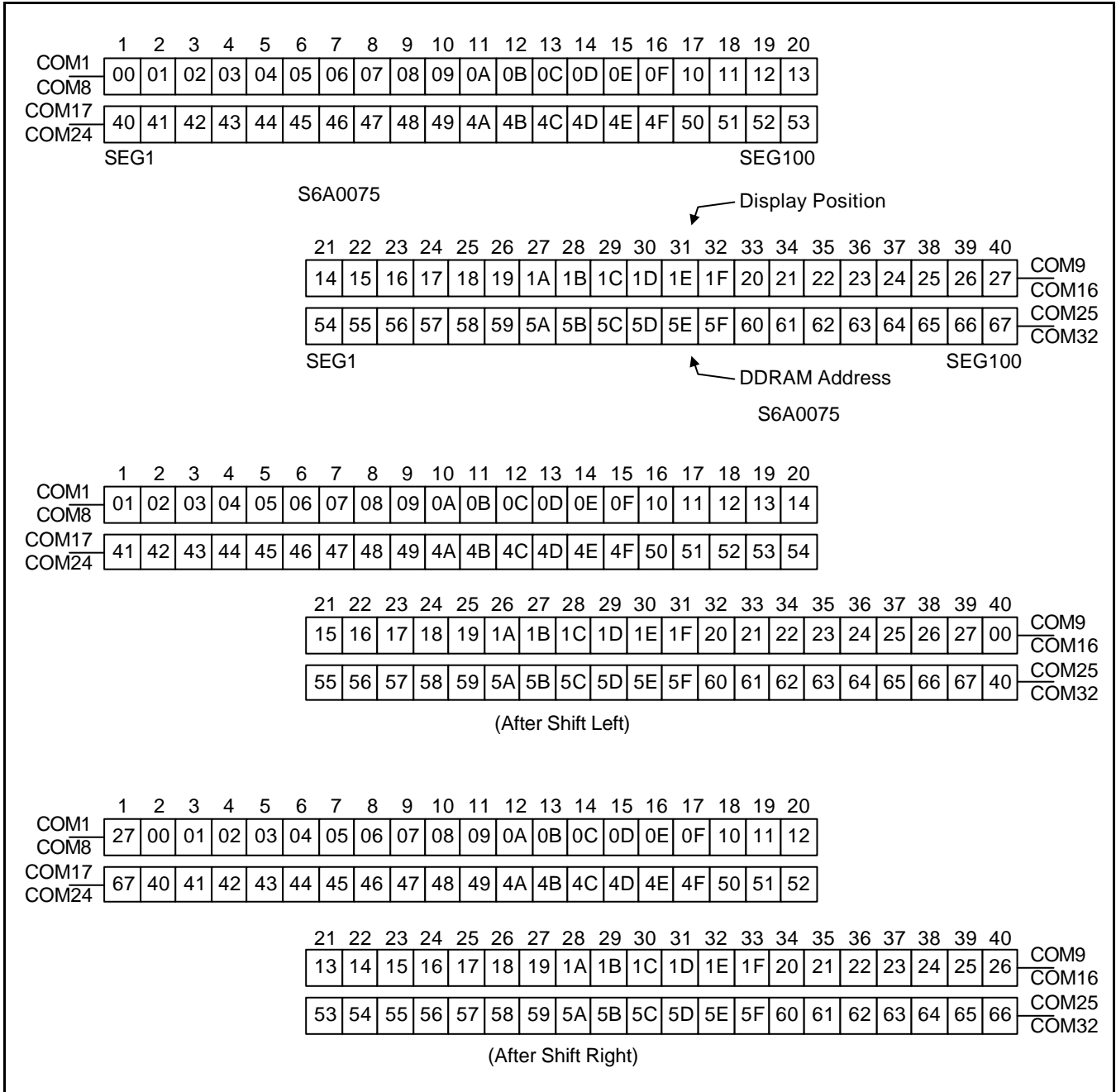

Figure 3. 2-line x 40ch. Display (5-dot Font Width)

5-dot 4-line Display

In case of 4-line display with 5-dot font, the address range of DDARM is 00H-13H, 20H-33H, 40H -53H, 60H-73H (refer to Figure 4).

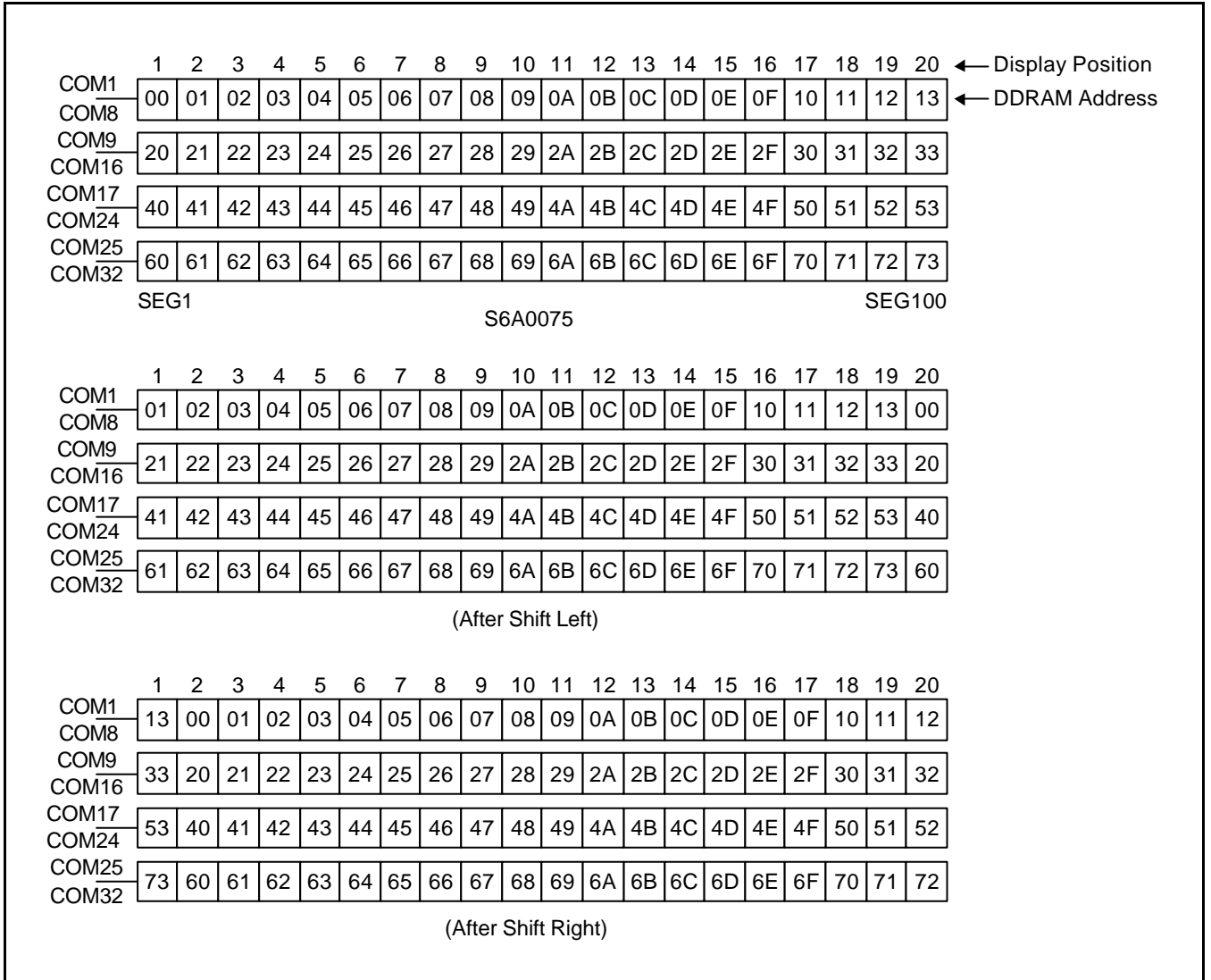

Figure 4. 4-line x 20ch. Display (5-dot Font Width)

DISPLAY OF 6-DOT FONT WIDTH CHARACTER

When this device is used in 6-dot font width mode, SEG97, SEG98, SEG99 and SEG100 must be open.

6-dot 1-line Display

In case of 1-line display with 6-dot font, the address range of DDRAM is 00H-4FH (refer to Figure 5).

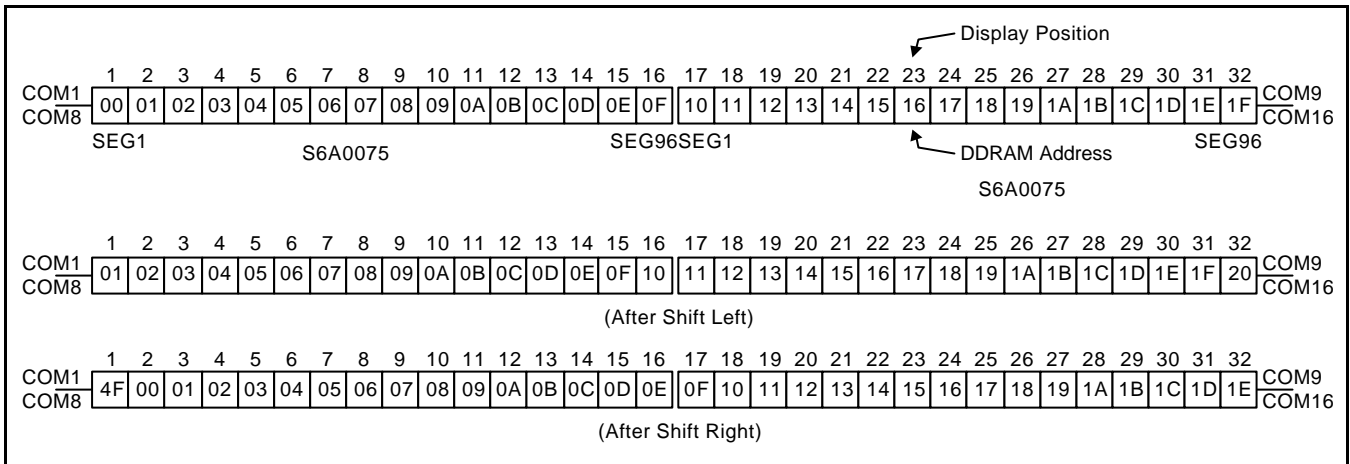

Figure 5. 1-line 32ch. Display

6-dot 2-line Display

In case of 2-line display with 6-dot font, the address range of DDRAM is 00H-27H, 40H-67H (refer to Figure 6).

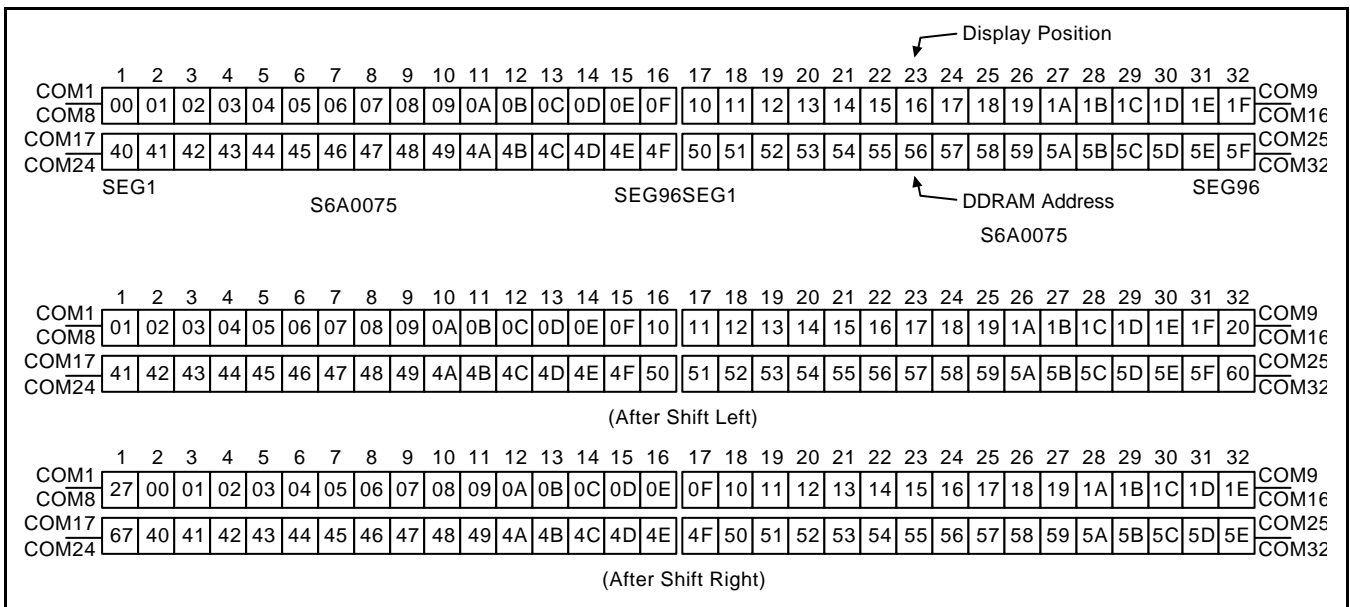

Figure 6. 2-line 32ch. Display (6-dot font width)

6-dot 4-line Display

In case of 4-line display with 6-dot font, the address range of DDARM is 00H-13H, 20H-33H, 40H-53H, 60H-73H (refer to Figure 7).

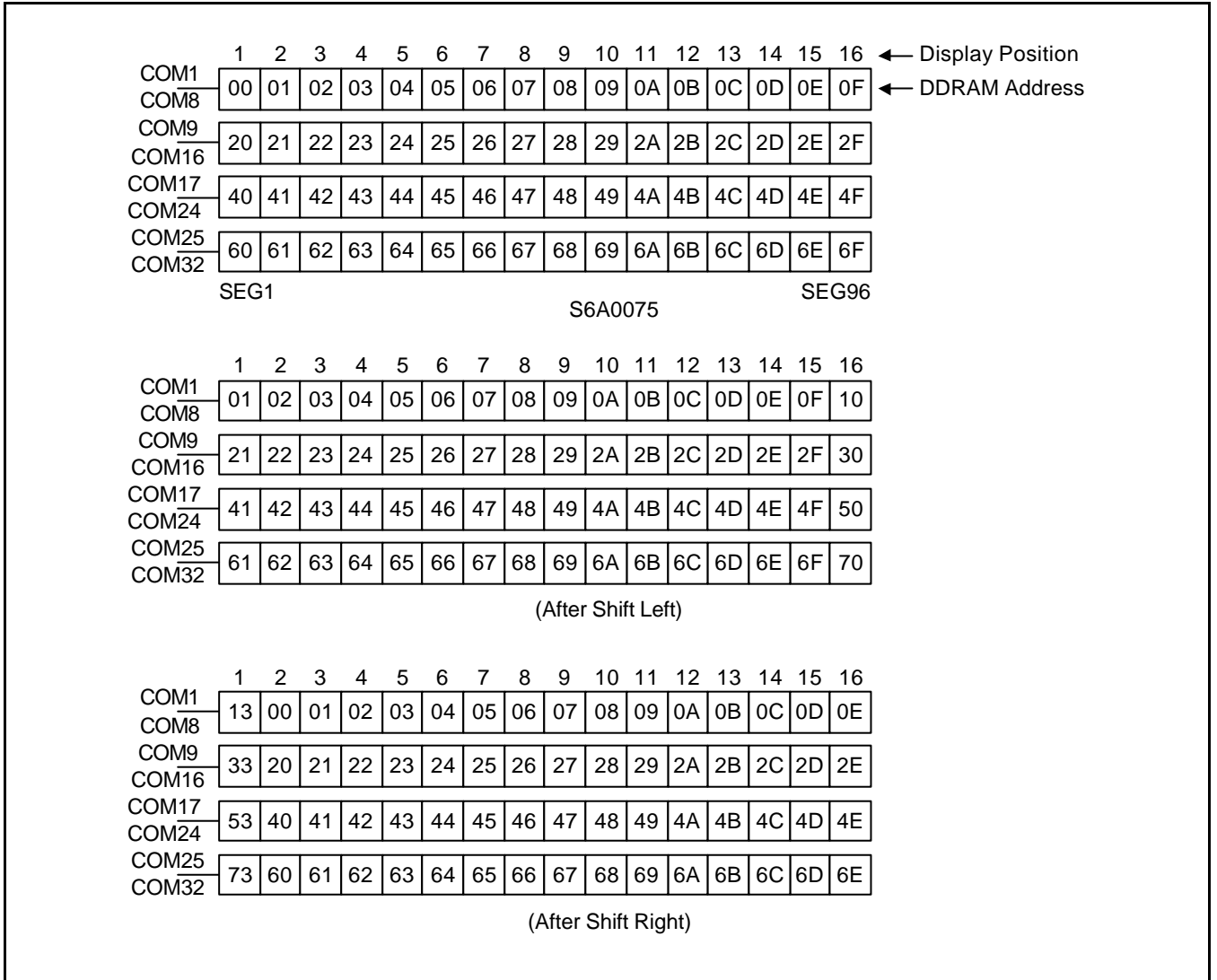

Figure 7. 4-line 16ch. Display (6-dot Font Width)

TIMING GENERATION CIRCUIT

Timing generation circuit generates clock signals for the internal operations.

ADDRESS COUNTER (AC)

Address Counter(AC) stores DDRAM/CGRAM/SEGRAM address, transferred from IR. After writing into (reading from) DDRAM/CGRAM/SEGRAM, AC is automatically increased (decreased) by 1. When RS = "Low" and R/W = "High", AC can be read through DB0-DB6

CURSOR/BLINK CONTROL CIRCUIT

It controls cursor/blink ON/OFF and black/white inversion at cursor position.

LCD DRIVER CIRCUIT

LCD Driver circuit has 34 common and 100 segment signals for LCD driving. Data from SEGRAM/CGRAM/CGROM is transferred to 100-bit segment latch serially, and then it is stored to 100-bit shift latch. When each com is selected by 34-bit common register, segment data also output through segment driver from 100-bit segment latch. In case of 1-line display mode, COM0-COM17 have 1/17 duty, and in 2-line or 4-line mode, COM0-COM33 have 1/33 duty ratio.

CGROM (CHARACTER GENERATOR ROM)

CGROM has 5 × 8 dots 240 Character Pattern.

CGRAM (CHARACTER GENERATOR RAM)

CGRAM has up to 5 × 8 dots 8 characters. By writing font data to CGRAM, user defined character can be used (refer to Table 4).

5 × 8 dots Character Pattern

Table 4. Relationship between Character Code(DDRAM) and Character Pattern(CGRAM)

Character Code (DDRAM data)								CGRAM Address				CGRAM Data								Pattern Number		
D7	D6	D5	D4	D3	D2	D1	D0	A5	A4	A3	A2	A1	A0	P7	P6	P5	P4	P3	P2		P1	P0
0	0	0	0	x	0	0	0	0	0	0	0	0	0	B1	B0	x	0	1	1	1	0	Pattern 1
											0	0	1				1	0	0	0	1	
											0	1	0				1	0	0	0	1	
				⋮						⋮	0	1	1			⋮	1	1	1	1	1	
				⋮						⋮	1	0	0			⋮	1	0	0	0	1	
				⋮						⋮	1	0	1			⋮	1	0	0	0	1	
				⋮						⋮	1	1	0			⋮	1	0	0	0	1	
											1	1	1				0	0	0	0	0	
				⋮						⋮												
0	0	0	0	x	1	1	1	1	1	1	0	0	0	B1	B0	x	1	0	0	0	1	Pattern 8
											0	0	1				1	0	0	0	1	
											0	1	0				1	0	0	0	1	
				⋮						⋮	0	1	1			⋮	1	1	1	1	1	
				⋮						⋮	1	0	0			⋮	1	0	0	0	1	
				⋮						⋮	1	0	1			⋮	1	0	0	0	1	
				⋮						⋮	1	1	0			⋮	1	0	0	0	1	
											1	1	1				0	0	0	0	0	

6 x 8 Dots Character Pattern

Character Code (DDRAM data)								CGRAM Address						CGRAM Data								Pattern Number
D7	D6	D5	D4	D3	D2	D1	D0	A5	A4	A3	A2	A1	A0	P7	P6	P5	P4	P3	P2	P1	P0	
0	0	0	0	x	0	0	0	0	0	0	0	0	0	B1	B0	0	0	1	1	1	0	Pattern 1
											0	0	1			0	1	0	0	0	1	
											0	1	0			0	1	0	0	0	1	
				.						.	0	1	1	.		0	1	1	1	1	1	
				.						.	1	0	0	.		0	1	0	0	0	1	
				.						.	1	0	1	.		0	1	0	0	0	1	
				.						.	1	1	0	.		0	1	0	0	0	1	
				.						.	1	1	1	.		0	0	0	0	0	0	
									
0	0	0	0	x	1	1	1	1	1	1	0	0	0	B1	B0	0	1	0	0	0	1	Pattern 8
											0	0	1			0	1	0	0	0	1	
											0	1	0			0	1	0	0	0	1	
				.						.	0	1	1	.		0	1	1	1	1	1	
				.						.	1	0	0	.		0	1	0	0	0	1	
				.						.	1	0	1	.		0	1	0	0	0	1	
				.						.	1	1	0	.		0	1	0	0	0	1	
				.						.	1	1	1	.		0	0	0	0	0	0	

NOTES:

- When BE (Blink Enable bit) = "High", blink is controlled by B1 and B0 bit.
In case of 5-dot font width, when B1 = "1", enabled dots of P0-P4 will blink, and when B1 = "0" and B0 = "1", enabled dots in P4 will blink, when B1 = "0" and B0 = "0", blink will not happen.
In case of 6-dot font width, when B1 = "1", enabled dots of P0-P5 will blink, and when B1 = "0" and B0 = "1", enabled dots of P5 will blink, when B1 = "0" and B0 = "0", blink will not happen.
- "X" is don't care.

SEGRAM (SEGMENT ICON RAM)

SEGRAM has segment control data and segment pattern data. During 1-line display mode, COM0 (COM17) makes the data of SEGRAM enable to display icons. When used in 2/4-line display mode COM0 (COM33) does that. Its higher 2-bit are blinking control data, and lower 6-bits are pattern data (refer to Table 5 and Figure 8).

Table 5. Relationship between SEGRAM Address and Display Pattern

SEGRAM Address				SEGRAM Data Display Pattern															
				5-dot Font Width								6-dot Font Width							
A3	A2	A1	A0	D7	D6	D5	D4	D3	D2	D1	D0	D7	D6	D5	D4	D3	D2	D1	D0
0	0	0	0	B1	B0	X	S1	S2	S3	S4	S5	B1	B0	S1	S2	S3	S4	S5	S6
0	0	0	1	B1	B0	X	S6	S7	S8	S9	S10	B1	B0	S7	S8	S9	S10	S11	S12
0	0	1	0	B1	B0	X	S11	S12	S13	S14	S15	B1	B0	S13	S14	S15	S16	S17	S18
0	0	1	1	B1	B0	X	S16	S17	S18	S19	S20	B1	B0	S19	S20	S21	S22	S23	S24
0	1	0	0	B1	B0	X	S21	S22	S23	S24	S25	B1	B0	S25	S26	S27	S28	S29	S30
0	1	0	1	B1	B0	X	S26	S27	S28	S29	S30	B1	B0	S31	S32	S33	S34	S35	S36
0	1	1	0	B1	B0	X	S31	S32	S33	S34	S35	B1	B0	S37	S38	S39	S40	S41	S42
0	1	1	1	B1	B0	X	S36	S37	S38	S39	S40	B1	B0	S43	S44	S45	S46	S47	S48
1	0	0	0	B1	B0	X	S41	S42	S43	S44	S45	B1	B0	S49	S50	S51	S52	S53	S54
1	0	0	1	B1	B0	X	S46	S47	S48	S49	S50	B1	B0	S55	S56	S57	S58	S59	S60
1	0	1	0	B1	B0	X	S51	S52	S53	S54	S55	B1	B0	S61	S62	S63	S64	S65	S66
1	0	1	1	B1	B0	X	S56	S57	S58	S59	S60	B1	B0	S67	S68	S69	S70	S71	S72
1	1	0	0	B1	B0	X	S61	S62	S63	S64	S65	B1	B0	S73	S74	S75	S76	S77	S78
1	1	0	1	B1	B0	X	S66	S67	S68	S69	S70	B1	B0	S79	S80	S81	S82	S83	S84
1	1	1	0	B1	B0	X	S71	S72	S73	S74	S75	B1	B0	S85	S86	S87	S88	S89	S90
1	1	1	1	B1	B0	X	S76	S77	S78	S79	S80	B1	B0	S91	S92	S93	S94	S95	S96

NOTE: B1, B0: Blinking control bit

Control Bit	Blinking Port	
BE B1 B0	5-dot font width	6-dot font width
0 X X	No blink	No blink
1 0 0	No blink	No blink
1 0 1	D4	D5
1 1 X	D4 - D0	D5 - D0

NOTES:

- S1-S80 : Icon pattern ON/OFF in 5-dot font width
S1-S96 : Icon pattern ON/OFF in 6-dot font width
- "X" is don't care.

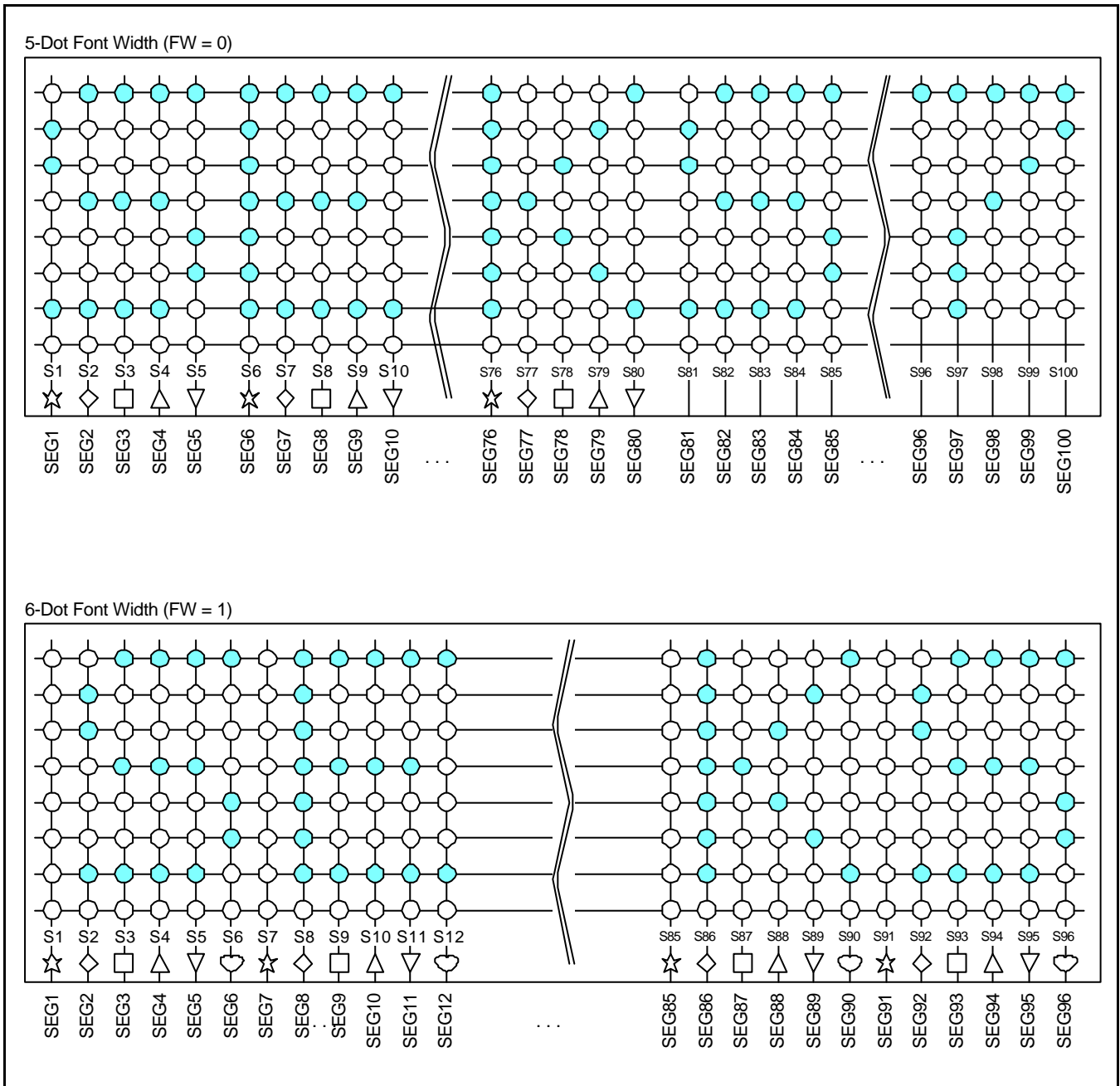

Figure 8. Relationship between SEGGRAM and Segment Display

INSTRUCTION DESCRIPTION

OUTLINE

To overcome the speed difference between internal clock of S6A0075 and MPU clock, S6A0075 performs internal operation by storing control information to IR or DR. The internal operation is determined according to the signal from MPU, composed of read/write and data bus. (refer to Table 6/10) Instruction can be divided largely four kinds,

- S6A0075 function set instructions (set display methods, set data length, etc.)
- Address set instructions to internal RAM
- Data transfer instructions with internal RAM
- Others

The address of internal RAM is automatically increased or decreased by 1.

When IE = "High", S6A0075 is operated according to instruction set 1 (Table 6) and when IE = "Low", S6A0075 is operated according to instruction set 2 (Table 10).

NOTE

During internal operation, busy flag (DB7) is read high. Busy flag check must precede the next instruction. When an MPU program with Busy Flag (DB7) checking is made, $1/2 f_{osc}$ (is necessary) for executing the next instruction by the falling edge of the "E" signal after the Busy Flag (DB7) goes to "Low".

INSTRUCTION DESCRIPTION 1 (IE = "HIGH")

Table 6. Instruction Set 1

Instruction	RE	Instruction Code										Description	Execution Time (fosc = 270kHz)	
		RS	R/W	DB7	DB6	DB5	DB4	DB3	DB2	DB1	DB0			
Clear display	X	0	0	0	0	0	0	0	0	0	0	1	Write "20H" to DDRAM. and set DDRAM address to "00H" from AC.	1.53ms
Return home	0	0	0	0	0	0	0	0	0	0	1	x	Set DDRAM address to "00H" from AC and return cursor to its original position if shifted. The contents of DDRAM are not changed.	1.53ms
Power down mode	1	0	0	0	0	0	0	0	0	0	1	PD	Set power down mode bit. PD = "1": power down mode set, PD = "0": power down mode disable	39μs
Entry mode set	0	0	0	0	0	0	0	0	0	1	I/D	S	Assign cursor moving direction. I/D = "1": increment, I/D = "0": decrement and display shift enable bit. S = "1": make display shift of the enabled lines by the DS4 DS1 bits in the shift enable instruction. S = "0": display shift disable	39μs
	1	0	0	0	0	0	0	0	0	1	1	B/D	Segment bi-direction function. BID = "0": Seg1 → Seg80, BID = "1": Seg80 → Seg1.	
Display ON/OFF Control	0	0	0	0	0	0	0	0	1	D	C	B	Set display/cursor/blink on/off D = "1": display on, D = "0": display off, C = "1": cursor on, C = "0": cursor off, B = "1": blink on, B = "0": blink off.	39μs

Table 6. Instruction Set 1 (Continued)

Instruction	RE	Instruction Code										Description	Execution Time (fosc = 270kHz)
		RS	R/W	DB7	DB6	DB5	DB4	DB3	DB2	DB1	DB0		
Extended function set	1	0	0	0	0	0	0	1	FW	B/W	NW	Assign font width, black/white inverting of cursor, and 4-line display mode control bit. FW = "1": 6-dot font width, FW = "0": 5-dot font width, B/W = "1": black/white inverting of cursor enable, B/W = "0": black/white inverting of cursor disable NW = "1": 4-line display mode, NW = "0": 1-line or 2-line display mode.	39μs
Cursor or Display Shift	0	0	0	0	0	0	1	S/C	R/L	x	x	Cursor or display shift. S/C = "1": display shift, S/C = "0": cursor shift, R/L = "1": shift to right, R/L = "0": shift to left.	39μs
Shift Enable	1	0	0	0	0	0	1	DS4	DS3	DS2	DS1	(when DH = "1") Determine the line for display shift. DS1 = "1/0": 1st line display shift enable/disable DS2 = "1/0": 2nd line display shift enable/disable DS3 = "1/0": 3rd line display shift enable/disable DS4 = "1/0": 4th line display shift enable/disable.	39μs
Scroll enable	1	0	0	0	0	0	1	HS4	HS3	HS2	HS1	(when DH = "0") Determine the line for horizontal smooth scroll. HS1 = "1/0": 1st line dot scroll enable/disable HS2 = "1/0": 2nd line dot scroll enable/disable HS3 = "1/0": 3rd line dot scroll enable/disable HS4 = "1/0": 4th line dot scroll enable/disable.	39μs

Table 6. Instruction Set 1 (Continued)

Instruction	RE	Instruction Code										Description	Execution Time (fosc = 270kHz)
		RS	R/W	DB7	DB6	DB5	DB4	DB3	DB2	DB1	DB0		
Function set	0	0	0	0	0	1	DL	N	RE (0)	DH	REV	Set interface data length (DL = "1": 8-bit, DL = "0": 4-bit), numbers of display line when NW = "0", (N = "1": 2-line, N = "0" : 1-line), extension register, RE("0"), shift/scroll enable DH = "1": display shift enable DH = "0": dot scroll enable. reverse bit REV = "1": reverse display, REV = "0": normal display.	39μs
	1	0	0	0	0	1	DL	N	RE (1)	BE	0	Set DL, N, RE("1") and CGRAM/SEGRAM blink enable (BE) BE = "1/0": CGRAM/SEGRAM blink enable/disable	39μs
Set CGRAM address	0	0	0	0	1	AC5	AC4	AC3	AC2	AC1	AC0	Set CGRAM address in address counter.	39μs
Set SEGRAM address	1	0	0	0	1	X	X	AC3	AC2	AC1	AC0	Set SEGRAM address in address counter.	39μs
Set DDRAM address	0	0	0	1	AC6	AC5	AC4	AC3	AC2	AC1	AC0	Set DDRAM address in address counter.	39μs
Set scroll quantity	1	0	0	1	X	QC5	QC4	QC3	QC2	QC1	QC0	Set the quantity of horizontal dot scroll.	39μs
Read busy flag and address	X	0	1	BF	AC6	AC5	AC4	AC3	AC2	AC1	AC0	Can be known whether during internal operation or not by reading BF. The contents of address counter can also be read. BF = "1": busy state BF = "0": ready state	0μs
Write data	X	1	0	D7	D6	D5	D4	D3	D2	D1	D0	Write data into internal RAM (DDRAM/CGRAM/SEGRAM).	43μs
Read data	X	1	1	D7	D6	D5	D4	D3	D2	D1	D0	Read data from internal RAM (DDRAM/CGRAM/SEGRAM).	43μs

NOTES:

- When a MPU program with busy flag (DB7) checking is made, 1/2 fosc (is necessary) for executing the next instruction by the "E" signal after the busy flag (DB7) goes to "Low"
- "X": Don't care

Display Clear

RS	R/W	DB7	DB6	DB5	DB4	DB3	DB2	DB1	DB0
0	0	0	0	0	0	0	0	0	1

Clear all the display data by writing "20H" (space code) to all DDRAM address, and set DDRAM address to "00H" into AC (address counter). Return cursor to the original status, namely, bring the cursor to the left edge on first line of the display. Make entry mode increment (I/D = "1").

Return Home (RE = 0)

RS	R/W	DB7	DB6	DB5	DB4	DB3	DB2	DB1	DB0
0	0	0	0	0	0	0	0	1	X

Return Home is cursor return home instruction. Set DDRAM address to "00H" into the address counter. Return cursor to its original site and return display to its original status, if shifted. Contents of DDRAM does not change.

Power Down Mode Set (RE = 1)

RS	R/W	DB7	DB6	DB5	DB4	DB3	DB2	DB1	DB0
1	0	0	0	0	0	0	0	1	PD

Power down mode enable bit set instruction. When PD = "High", it makes S6A0075 suppress current consumption except the current needed for data storage by executing next three functions.

- Make the output value of all the COM/SEG ports VDD
- Make the COM/SEG output value of extension driver VDD by setting D output to "High" and M output to "Low"
- Disable voltage converter to remove the current through the divide resistor of power supply.
You can use this instruction as power sleep mode.
When PD = "Low", power down mode becomes disabled.

Entry Mode Set (RE = 0)

RS	R/W	DB7	DB6	DB5	DB4	DB3	DB2	DB1	DB0
0	0	0	0	0	0	0	1	I/D	S

Set the moving direction of cursor and display.

I/D: Increment/decrement of DDRAM address (cursor or blink)

When I/D = "High", cursor/blink moves to right and DDRAM address is increased by 1.

When I/D = "Low", cursor/blink moves to left and DDRAM address is decreased by 1.

— CGRAM/SEGRAM operates the same as DDRAM, when read from or write to CGRAM/SEGRAM.

When S = "High", after DDRAM write, the display of enabled line by DS1 - DS4 bits in the shift enable instruction is shifted to the right (I/D = "0") or to the left (I/D = "1"). But it will seem as if the cursor does not move. When S = "Low", or DDRAM read, or CGRAM/SEGRAM read/write operation, shift of display like this function is not performed.

Entry Mode Set (RE = 1)

RS	R/W	DB7	DB6	DB5	DB4	DB3	DB2	DB1	DB0
0	0	0	0	0	0	0	1	1	BID

Set the data shift direction of segment in the application set.

BID: Data shift direction of segment

When BID = "Low", segment data shift direction is set to normal order from SEG1 to SEG100.

When BID = "High", segment data shift direction is set to reverse from SEG100 to SEG1.

By using this instruction, you can raise the efficiency of application board area.

— The BID setting instruction is recommended to be set at the same time level of function set instruction.

— DB1 bit must be set to "1".

Display ON/OFF Control (RE = 0)

RS	R/W	DB7	DB6	DB5	DB4	DB3	DB2	DB1	DB0
0	0	0	0	0	0	1	D	C	B

Control display/cursor/blink ON/OFF 1 bit register.

- D: Display ON/OFF control bit
When D = "High", entire display is turned on.
When D = "Low", display is turned off, but display data is remained in DDRAM.
- C: Cursor ON/OFF control bit
When C = "High", cursor is turned on.
When C = "Low", cursor is disappeared in current display, but I/D register remains its data.
- B: Cursor Blink ON/OFF control bit
When B = "High", cursor blink is on, that performs alternate between all the high data and display character at the cursor position. If fosc has 270kHz frequency, blinking has 370 ms interval.
When B = "Low", blink is off.

Extended Function Set (RE = 1)

RS	R/W	DB7	DB6	DB5	DB4	DB3	DB2	DB1	DB0
0	0	0	0	0	0	1	FW	B/W	NW

- FW: Font Width control
When FW = "High", display character font width is assigned to 6-dot and execution time becomes 6/5 times than that of 5-dot font width.
The user font, specified in CGRAM, is displayed into 6-dot font width, bit-5 to bit-0, including the leftmost space bit of CGRAM.(refer to Figure 9)
When FW = "Low", 5-dot font width is set.
- B/W: Black/White Inversion enable bit
When B/W = "High", black/white inversion at the cursor position is set. In this case C/B bit of display ON/OFF control instruction becomes don't care condition. If fosc has frequency of 270kHz, inversion has 370 ms intervals.
- NW: 4 Line mode enable bit
When NW = "High", 4 line display mode is set. In this case N bit of function set instruction becomes don't care condition.

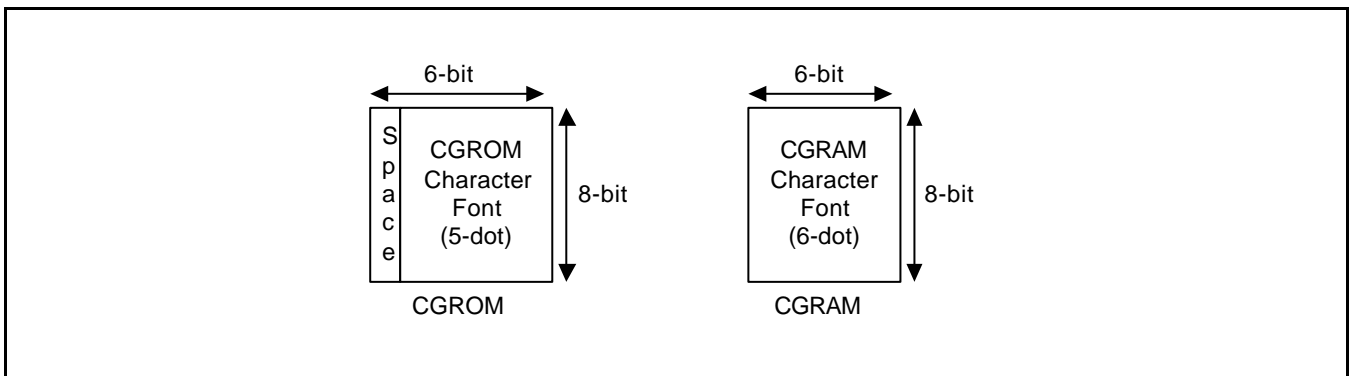

Figure 9. 6-dot Font Width CGROM/CGRAM

Cursor or Display Shift (RE = 0)

RS	R/W	DB7	DB6	DB5	DB4	DB3	DB2	DB1	DB0
0	0	0	0	0	1	S/C	R/L	x	x

Shift right/left cursor position or display, without writing or reading of display data, this instruction is use to correct or search display data (refer to Table 7). During 2-line mode display, cursor moves to the 2nd line after 40th digit of 1st line. When 4-line mode, cursor moves to the next line, only after every 20th digit of the current line. Note that display shift is performed simultaneously in all the line enabled by DS1-DS4 in the shift enable instruction. When displayed data is shifted repeatedly, each line shifted individually. When display shift is performed, the contents of address counter are not changed. During low power consumption mode, display shift may not be performed normally.

Table 7. Shift Patterns According to S/C and R/L Bits

S/C	R/L	Operation
0	0	Shift cursor to the left, address counter is decreased by 1
0	1	Shift cursor to the right, address counter is increased by 1
1	0	Shift all the display to the left, cursor moves according to the display
1	1	Shift all the display to the right, cursor moves according to the display

Shift/Scroll Enable (RE = 1)

(DH = 0)

RS	R/W	DB7	DB6	DB5	DB4	DB3	DB2	DB1	DB0
0	0	0	0	0	1	HS4	HS3	HS2	HS1

HS: Horizontal scroll per line enable

This instruction makes valid dot shift by a display line unit. HS1, HS2, HS3 and HS4 indicate each line to be dot scrolled, and each scroll is performed individually in each line.

If you want to scroll the line in 1-line display mode or the 1st line in 2-line display mode, set HS1 and HS2 to "High".

If the 2nd line scroll is needed in 2-line mode, set HS3 and HS4 to "High". (refer to Table 8)

(DH = 1)

RS	R/W	DB7	DB6	DB5	DB4	DB3	DB2	DB1	DB0
0	0	0	0	0	1	DS4	DS3	DS2	DS1

DS: Display shift per line enable this instruction selects shifting line to be shifted according to each line mode in display shift right/left instruction. DS1, DS2, DS3 and DS4 indicate each line to be shifted, and each shift is performed individually in each line.

If you set DS1 and DS2 to "High" (enable) in 2 line mode, only the 1st line is shifted and the 2nd line is not shifted. When only DS1 = "High", only the half of the 1st line is shifted. If all the DS bits (DS1 to DS4) are set to "Low" (disable), no display is shifted.

Table 8. Relationship between DS and COM signal

Enable Bit	Enabled Common Signals During Shift	Description
HS1/DS1	COM1 - COM8	The part of display line that corresponds to enabled common signal can be shifted.
HS2/DS2	COM9 - COM16	
HS3/DS3	COM17 - COM24	
HS4/DS4	COM25 - COM32	

Function Set (RE = 0)

RS	R/W	DB7	DB6	DB5	DB4	DB3	DB2	DB1	DB0
0	0	0	0	1	DL	N	RE(0)	DH	REV

- DL:** Interface data length control bit
 When DL = "High", it means 8-bit bus mode with MPU.
 When DL = "Low", it means 4-bit bus mode with MPU. So to speak, DL is a signal to select 8-bit or 4-bit bus mode.
 When 4-bit bus mode, it needs to transfer 4-bit data by two times.
- N:** Display line number control bit
 It is variable only when NW bit of extended function set instruction is low.
 When N = "Low", it means 1-line display mode.
 When N = "High", 2-line display mode is set.
 When NW = "High", N bit is invalid, it means 4-line mode independent of N bit.
- RE:** Extended function registers enable bit
 At this instruction, RE must be "Low".
- DH:** Display shift enable selection bit.
 When DH = "High", display shift per line becomes enable.
 When DH = "Low", smooth dot scroll becomes enable.
 This bit can be accessed only when IE pin input is "High".
- REV:** Reverse enable bit
 When REV = "High", all the display data are reversed. Namely, all the white dots become black and black dots become white.
 When REV = "Low", the display mode set normal display.

Function Set (RE = 1)

RS	R/W	DB7	DB6	DB5	DB4	DB3	DB2	DB1	DB0
0	0	0	0	1	DL	N	RE(1)	BE	0

- DL:** Interface data length control bit
 When DL = "High", it means 8-bit bus mode with MPU.
 When DL = "Low", it means 4-bit bus mode with MPU.
 So to speak, DL is a signal to select 8-bit or 4-bit bus mode.
 When 4-bit bus mode, it needs to transfer 4-bit data by two times.
- N:** Display line number control bit
 It is variable only when NW bit of extended function set instruction is Low.
 When N = "Low", it means 1-line display mode.
 When N = "High", 2-line display mode is set.
 When NW = "High", N bit is invalid, it means 4-line mode independent of N bit.
- RE:** Extended function registers enable bit
 When RE = "High", extended function set registers, SEGRAM address set registers, BID bit, HS/DS bits of shift/scroll enable instruction and BE bits of function set register can be accessed.
- BE:** CGRAM/SEGRAM data blink enable bit
 If BE is "High", It makes user font of CGRAM and segment of SEGRAM blink. The quantity of blink is assigned the highest 2 bit of CGRAM/SEGRAM.

Set CGRAM Address (RE = 0)

RS	R/W	DB7	DB6	DB5	DB4	DB3	DB2	DB1	DB0
0	0	0	1	AC5	AC4	AC3	AC2	AC1	AC0

Set CGRAM address to AC. This instruction makes CGRAM data available from MPU.

Set SEGRAM Address (RE = 1)

RS	R/W	DB7	DB6	DB5	DB4	DB3	DB2	DB1	DB0
0	0	0	1	x	x	AC3	AC2	AC1	AC0

Set CGRAM address to AC. This instruction makes CGRAM data available from MPU.

Set DDRAM Address (RE = 0)

RS	R/W	DB7	DB6	DB5	DB4	DB3	DB2	DB1	DB0
0	0	1	AC6	AC5	AC4	AC3	AC2	AC1	AC0

Set DDRAM address to AC. This instruction makes DDRAM data available from MPU. When 1-line display mode (N = 0, NW = 0), DDRAM address is from "00H" to "4FH". In 2-line display mode (N = 1, NW = 0), DDRAM address in the 1st line is from "00H" - "27H", and DDRAM address in the 2nd line is from "40H" - "67H". In 4-line display mode (NW = 1), DDRAM address is from "00H" - "13H" in the 1st line, from "20H" to "33H" in the 2nd line, from "40H" - "53H" in the 3rd line and from "60H" - "73H" in the 4th line.

Set Scroll Quantity (RE = 1)

RS	R/W	DB7	DB6	DB5	DB4	DB3	DB2	DB1	DB0
0	0	1	x	SQ	SQ4	SQ3	SQ2	SQ1	SQ0

As set SQ5 to SQ0, horizontal scroll quantity can be controlled in dot units (Refer to Table 9). In this case S6A0075 can show hidden areas of DDRAM by executing smooth scroll from 1 to 48 dots.

Table 9. Scroll Quantity According to HDS bits

SQ5	SQ4	SQ3	SQ2	SQ1	SQ0	Function
0	0	0	0	0	0	No shift
0	0	0	0	0	1	Shift left by 1-dot
0	0	0	0	1	0	Shift left by 2-dot
0	0	0	0	1	1	Shift left by 3-dot
:	:	:	:	:	:	:
1	0	1	1	1	1	Shift left by 47-dot
1	1	x	x	x	x	Shift left by 48-dot

Read Busy Flag & Address

RS	R/W	DB7	DB6	DB5	DB4	DB3	DB2	DB1	DB0
0	1	BF	AC6	AC5	AC4	AC3	AC2	AC1	AC0

This instruction shows whether S6A0075 is in internal operation or not. If the resultant BF is High, it means the internal operation is in progress and you have to wait until BF to be Low, and then the next instruction can be performed. In this instruction you can read also the value of address counter.

Write Data to RAM

RS	R/W	DB7	DB6	DB5	DB4	DB3	DB2	DB1	DB0
1	0	D7	D6	D5	D4	D3	D2	D1	D0

Write binary 8-bit data to DDRAM/CGRAM/SEGRAM. The selection of RAM from DDRAM, CGRAM, or SEGRAM, is set by the previous address set instruction: DDRAM address set, CGRAM address set, SEGRAM address set. RAM set instruction can also determines the AC direction to RAM. After write operation, the address is automatically increased/decreased by 1, according to the entry mode.

Read Data From RAM

RS	R/W	DB7	DB6	DB5	DB4	DB3	DB2	DB1	DB0
1	1	D7	D6	D5	D4	D3	D2	D1	D0

Read binary 8-bit data from DDRAM/CGRAM/SEGRAM. The selection of RAM is set by the previous address set instruction. If address set instruction of RAM is not performed before this instruction, the data that read first is invalid, because the direction of AC is not determined. If you read RAM data several times without RAM address set instruction before read operation, you can get correct RAM data from the second, but the first data would be incorrect, because there is no time margin to transfer RAM data. In case of DDRAM read operation, cursor shift instruction plays the same role as DDRAM address set instruction : it also transfer RAM data to output data register. After read operation address counter is automatically increased/decreased by 1 according to the entry mode. After CGRAM/SEGRAM read operation, display shift may not be executed correctly. In case of RAM write operation, after this AC is increased/decreased by 1 like read operation. In this time, AC indicates the next address position, but you can read only the previous data by read instruction.

INSTRUCTION DESCRIPTION 2 (IE = "LOW")

Table 10. Instruction Set 2

Instruction	RE	Instruction Code										Description	Execution Time (fosc = 270kHz)	
		RS	R/W	DB7	DB6	DB5	DB4	DB3	DB2	DB1	DB0			
Clear display	X	0	0	0	0	0	0	0	0	0	0	1	Write "20H" to DDRAM. and set DDRAM address to "00H" from AC.	1.53ms
Return home	X	0	0	0	0	0	0	0	0	0	1	x	Set DDRAM address to "00H" from AC and return cursor to its original position if shifted. The contents of DDRAM are not changed.	1.53ms
Entry mode set	X	0	0	0	0	0	0	0	0	1	I/D	S	Assign cursor moving direction. I/D = "1": increment, I/D = "0": decrement. and display shift enable bit. S = "1": make entire display shift of all lines during DDRAM write, S = "0": display shift disable	39μs
Display ON/OFF control	0	0	0	0	0	0	0	0	1	D	C	B	Set display/cursor/blink on/off D = "1": display on, D = "0": display off, C = "1": cursor on, C = "0": cursor off, B = "1": blink on, B = "0": blink off.	39μs
Extended function set	1	0	0	0	0	0	0	0	1	FW	B/W	NW	Assign font width, black/white inverting of cursor, and 4-line display mode control bit. FW = "1": 6-dot font width, FW = "0": 5-dot font width, B/W = "1": black/white inverting of cursor enable, B/W = "0": black/white inverting of cursor disable NW = "1": 4-line display mode, NW = "0": 1-line or 2-line display mode	39μs
Cursor or display shift	0	0	0	0	0	0	0	1	S/L	R/L	X	X	Cursor or display shift. S/C = "1": display shift, S/C = "0": cursor shift, R/L = "1": shift to right, R/L = "0": shift to left	39μs

Table 10. Instruction Set 2 (Continued)

Instruction	RE	Instruction Code										Description	Execution Time (fosc = 270kHz)
		RS	R/W	DB7	DB6	DB5	DB4	DB3	DB2	DB1	DB0		
Scroll Enable	1	0	0	0	0	0	1	HS4	HS3	HS2	HS1	Determine the line for horizontal smooth scroll. HS1 = "1/0": 1st line dot scroll enable/disable HS2 = "1/0": 2nd line dot scroll enable/disable HS3 = "1/0": 3rd line dot scroll enable/disable HS4 = "1/0": 4th line dot scroll enable/disable	39μs
Function Set	0	0	0	0	0	1	DL	N	RE (0)	X	X	Set interface data length DL = "1": 8-bit, DL = "0": 4-bit numbers of display line when NW = "0", N = "1": 2-line, N = "0": 1-line extension register, RE("0")	39μs
	1	0	0	0	0	1	DL	N	RE (1)	BE	0	Set DL, N, RE("1") and CGRAM/SEGRAM blink enable (BE) BE = "1/0": CGRAM/SEGRAM blink enable/disable	39μs
Set CGRAM address	0	0	0	0	1	AC5	AC4	AC3	AC2	AC1	AC0	Set CGRAM address in address counter.	39μs
Set SEGRAM address	1	0	0	0	1	X	X	AC3	AC2	AC1	AC0	Set SEGRAM address in address counter.	39μs
Set DDRAM address	0	0	0	1	AC6	AC5	AC4	AC3	AC2	AC1	AC0	Set DDRAM address in address counter.	39μs
Set scroll quantity	1	0	0	1	X	SQ5	SQ4	SQ3	SQ2	SQ1	SQ0	Set the quantity of horizontal dot scroll.	39μs
Read busy flag and address	X	0	1	BF	AC6	AC5	AC4	AC3	AC2	AC1	AC0	Can be known whether during internal operation or not by reading BF. The contents of address counter can also be read. BF = "1": busy state, BF = "0": ready state.	0μs

Table 10. Instruction Set 2 (Continued)

Instruction	RE	Instruction Code										Description	Execution Time (fosc = 270kHz)
		RS	R/W	DB7	DB6	DB5	DB4	DB3	DB2	DB1	DB0		
Write data	X	1	0	D7	D6	D5	D4	D3	D2	D1	D0	Write data into internal RAM (DDRAM/CGRAM/SEGRAM).	43μs
Read data	X	1	1	D7	D6	D5	D4	D3	D2	D1	D0	Read data from internal RAM (DDRAM/CGRAM/SEGRAM).	43μs

NOTES:

1. When an MPU program with Busy Flag (DB7) checking is made, 1/2 fosc (is necessary) for executing the next instruction by the falling edge of the "E" signal after the Busy Flag (DB7) goes to "Low".
2. "X" is don't care.

Display Clear

RS	R/W	DB7	DB6	DB5	DB4	DB3	DB2	DB1	DB0
0	0	0	0	0	0	0	0	0	1

Clear all the display data by writing "20H" (space code) to all DDRAM address, and set DDRAM address to "00H" into AC (address counter). Return cursor to the original status, namely, bring the cursor to the left edge on first line of the display. And entry mode is set to increment mode (I/D = "1").

Return Home

RS	R/W	DB7	DB6	DB5	DB4	DB3	DB2	DB1	DB0
0	0	0	0	0	0	0	0	1	X

Return Home is cursor return home instruction. Set DDRAM address to "00H" into the address counter. Return cursor to its original site and return display to its original status, if shifted. Contents of DDRAM does not change.

Entry Mode Set

RS	R/W	DB7	DB6	DB5	DB4	DB3	DB2	DB1	DB0
0	0	0	0	0	0	0	1	I/D	S

Set the moving direction of cursor and display.

I/D: Increment/decrement of DDRAM address (cursor or blink)
 When I/D = "High", cursor/blink moves to right and DDRAM address is increased by 1.
 When I/D = "Low", cursor/blink moves to left and DDRAM address is decreased by 1.

- CGRAM/SEGRAM operates the same as DDRAM, when read from or write to CGRAM/SEGRAM.

When S = "High", after DDRAM write, the entire display of all lines is shifted to the right (I/D = "0") or to the left (I/D = "1"). But it will seem as if the cursor does not move. When S = "Low", or DDRAM read, or CGRAM/SEGRAM read/write operation, shift of entire display is not performed.

Display ON/OFF Control (RE = 0)

RS	R/W	DB7	DB6	DB5	DB4	DB3	DB2	DB1	DB0
0	0	0	0	0	0	1	D	C	B

Control display/cursor/blink ON/OFF 1 bit register.

- D: Display ON/OFF control bit
When D = "High", entire display is turned on.
When D = "Low", display is turned off, but display data is remained in DDRAM.
- C: Cursor ON/OFF control bit
When C = "High", cursor is turned on.
When C = "Low", cursor is disappeared in current display, but I/D register remains its data.
- B: Cursor Blink ON/OFF control bit
When B = "High", cursor blink is on, that performs alternate between all the high data and display character at the cursor position. If fosc has 270kHz frequency, blinking has 370 ms interval.
When B = "Low", blink is off.

Extended Function Set (RE = 1)

RS	R/W	DB7	DB6	DB5	DB4	DB3	DB2	DB1	DB0
0	0	0	0	0	0	1	FW	B/W	NW

- FW: Font width control
When FW = "High", display character font width is assigned to 6-dot and execution time becomes 6/5 times than that of 5-dot font width.
The user font, specified in CGRAM, is displayed into 6-dot font width, bit-5 to bit-0, including the leftmost pace bit of CGRAM. (Refer to Figure 10)
When FW = "Low", 5-dot font width is set.
- B/W: Black/White Inversion enable bit
When B/W = "High", black/white inversion at the cursor position is set. In this case C/B bit of display ON/OFF control instruction becomes don't care condition. If fosc has frequency of 270kHz, inversion has 370 ms intervals.
- NW: 4 Line mode enable bit
When NW = "High", 4 line display mode is set. In this case N bit of function set instruction becomes don't care condition.

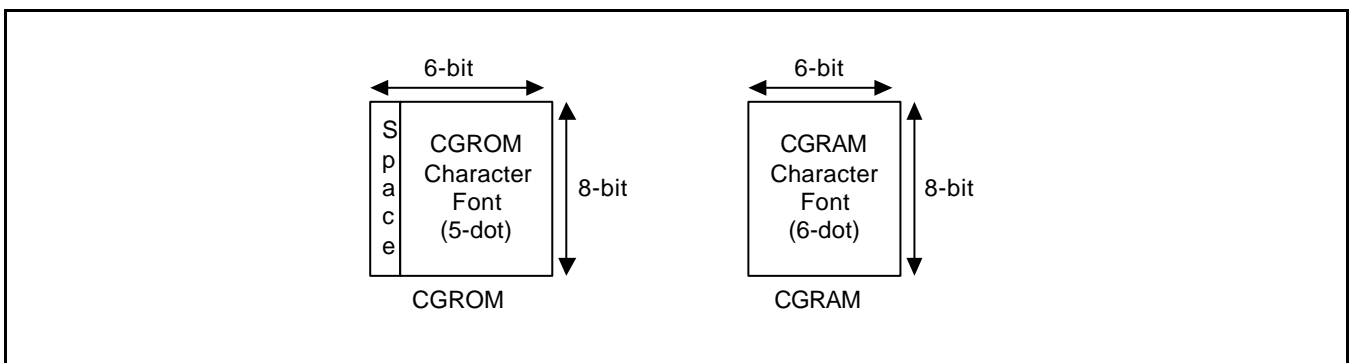

Figure 10. 6-dot font width CGROM/CGRAM

Cursor or Display Shift (RE = 0)

RS	R/W	DB7	DB6	DB5	DB4	DB3	DB2	DB1	DB0
0	0	0	0	0	1	S/C	R/L	x	x

Without writing or reading of display data, shift right/left cursor position or display. This instruction is used to correct or search display data.(Refer to Table 11) during 2-line mode display, cursor moves to the 2nd line after 40th digit of 1st line. When 4-line mode, cursor moves to the next line, only after every 20th digit of the current line. Note that display shift is performed simultaneously in all the line. When displayed data is shifted repeatedly, each line shifted individually. When display shift is performed, the contents of address counter are not changed.

Table 11. Shift Patterns According to S/C and R/L Bits

S/C	R/L	Operation
0	0	Shift cursor to the left, address counter is decreased by 1
0	1	Shift cursor to the right, address counter is increased by 1
1	0	Shift all the display to the left, cursor moves according to the display
1	1	Shift all the display to the right, cursor moves according to the display

Scroll Enable (RE = 1)

RS	R/W	DB7	DB6	DB5	DB4	DB3	DB2	DB1	DB0
0	0	0	0	0	1	HS4	HS3	HS2	HS1

HS: Horizontal scroll per line enable

This instruction makes valid dot shift by a display line unit. HS1, HS2, HS3 and HS4 indicate each line to be dot scrolled, and each scroll is performed individually in each line.

If you want to scroll the line in 1-line display mode or the 1st line in 2-line display mode, set HS1 and HS2 to "High". If the 2nd line scroll is needed in 2-line mode, set HS3 and HS4 to "High".

(refer to Table 8)

Function Set (RE = 0)

RS	R/W	DB7	DB6	DB5	DB4	DB3	DB2	DB1	DB0
0	0	0	0	1	DL	N	RE(0)	x	x

- DL:** Interface data length control bit
 When DL = "High", it means 8-bit bus mode with MPU.
 When DL = "Low", it means 4-bit bus mode with MPU. So to speak, DL is a signal to select 8-bit or 4-bit bus mode.
 When 4-bit bus mode, it needs to transfer 4-bit data by two times.
- N:** Display line number control bit
 It is variable only when NW bit of extended function set instruction is Low.
 When N = "Low", it means 1-line display mode.
 When N = "High", 2-line display mode is set.
 When NW = "High", N bit is invalid, it means 4-line mode independent of N bit.
- RE:** Extended function registers enable bit
 At this instruction, RE must be "Low".

Function Set (RE = 1)

RS	R/W	DB7	DB6	DB5	DB4	DB3	DB2	DB1	DB0
0	0	0	0	1	DL	N	RE(1)	BE	0

- DL:** Interface data length control bit
 When DL = "High", it means 8-bit bus mode with MPU.
 When DL = "Low", it means 4-bit bus mode with MPU. So to speak, DL is a signal to select 8-bit or 4-bit bus mode.
 When 4-bit bus mode, it needs to transfer 4-bit data by two times.
- N:** Display line number control bit
 It is variable only when NW bit of extended function set instruction is Low.
 When N = "Low", it means 1-line display mode.
 When N = "High", 2-line display mode is set.
 When NW = "High", N bit is invalid, it means 4-line mode independent of N bit.
- RE:** Extended function registers enable bit
 When RE = "High", extended function set registers, SEGRAM address set registers, HS bits of scroll enable instruction and BE bits of function set register can be accessed.
- BE:** CGRAM/SEGRAM data blink enable bit
 If BE is "High", It makes user font of CGRAM and segment of SEGRAM blink. The quantity of blink is assigned the highest 2 bit of CGRAM/SEGRAM.

Set CGRAM Address (RE = 0)

RS	R/W	DB7	DB6	DB5	DB4	DB3	DB2	DB1	DB0
0	0	0	1	AC5	AC4	AC3	AC2	AC1	AC0

Set CGRAM address to AC. This instruction makes CGRAM data available from MPU.

Set SEGRAM Address (RE = 1)

RS	R/W	DB7	DB6	DB5	DB4	DB3	DB2	DB1	DB0
0	0	0	1	x	x	AC3	AC2	AC1	AC0

Set SEGRAM address to AC. This instruction makes SEGRAM data available from MPU.

Set DDRAM Address (RE = 0)

RS	R/W	DB7	DB6	DB5	DB4	DB3	DB2	DB1	DB0
0	0	1	AC6	AC5	AC4	AC3	AC2	AC1	AC0

Set DDRAM address to AC.

This instruction makes DDRAM data available from MPU. When 1-line display mode (N = 0, NW = 0), DDRAM address is from "00H" to "4FH". In 2-line display mode (N = 1, NW = 0), DDRAM address in the 1st line is from "00H" to "27H", and DDRAM address in the 2nd line is from "40H" to "67H". In 4-line display mode (NW = 1), DDRAM address is from "00H" to "13H" in the 1st line, from "20H" to "33H" in the 2nd line, from "40H" to "53H" in the 3rd line and from "60H" to "73H" in the 4th line.

Set Scroll Quantity (RE = 1)

RS	R/W	DB7	DB6	DB5	DB4	DB3	DB2	DB1	DB0
0	0	1	x	SQ5	SQ4	SQ3	SQ2	SQ1	SQ0

As set SQ5 to SQ0, horizontal scroll quantity can be controlled in dot units (refer to Table 12). In this case S6A0075 execute dot smooth scroll from 1 to 48 dots.

Table 12. Scroll Quantity According to HDS bits

SQ5	SQ4	SQ3	SQ2	SQ1	SQ0	Function
0	0	0	0	0	0	No shift
0	0	0	0	0	1	Shift left by 1-dot
0	0	0	0	1	0	Shift left by 2-dot
0	0	0	0	1	1	Shift left by 3-dot
:	:	:	:	:	:	:
1	0	1	1	1	1	Shift left by 47-dot
1	1	x	x	x	x	Shift left by 48-dot

Read Busy Flag & Address

RS	R/W	DB7	DB6	DB5	DB4	DB3	DB2	DB1	DB0
0	1	BF	AC6	AC5	AC4	AC3	AC2	AC1	AC0

This instruction shows whether S6A0075 is in internal operation or not. If the resultant BF is High, it means the internal operation is in progress and you have to wait until BF to be low, and then the next instruction can be performed. In this instruction you can read also the value of address counter.

Write Data to RAM

RS	R/W	DB7	DB6	DB5	DB4	DB3	DB2	DB1	DB0
1	0	D7	D6	D5	D4	D3	D2	D1	D0

Write binary 8-bit data to DDRAM/CGRAM/SEGRAM. The selection of RAM from DDRAM, CGRAM, or SEGRAM, is set by the previous address set instruction : DDRAM address set, CGRAM address set, SEGRAM address set. RAM set instruction can also determines the AC direction to RAM. After write operation, the address is automatically increased/decreased by 1, according to the entry mode.

Read Data From RAM

RS	R/W	DB7	DB6	DB5	DB4	DB3	DB2	DB1	DB0
1	1	D7	D6	D5	D4	D3	D2	D1	D0

Read binary 8-bit data from DDRAM/CGRAM/SEGRAM. The selection of RAM is set by the previous address set instruction. If address set instruction of RAM is not performed before this instruction, the data that read first is invalid, because the direction of AC is not determined. If you read RAM data several times without RAM address set instruction before read operation, you can get correct RAM data from the second, but the first data would be incorrect, because there is no time margin to transfer RAM data. In case of DDRAM read operation, cursor shift instruction plays the same role as DDRAM address set instruction : it also transfer RAM data to output data register. After read operation address counter is automatically increased/decreased by 1 according to the entry mode. After CGRAM/SEGRAM read operation, display shift may not be executed correctly.

- In case of RAM write operation, after this AC is increased/decreased by 1 like read operation. In this time, AC indicates the next address position, but you can read only the previous data by read instruction.

INTERFACE WITH MPU

S6A0075 can transfer data in bus mode (4-bit or 8-bit) or serial mode with MPU. So you can use any type 4 or 8-bit MPU.

In case of 4-bit bus mode, data transfer is performed by two times to transfer 1 byte data.

- When interfacing data length are 4-bit, only 4 ports, from DB4 - DB7, are used as data bus.
- At first higher 4-bit (in case of 8-bit bus mode, the contents of DB4 - DB7) are transferred, and then lower 4-bit (in case of 8-bit bus mode, the contents of DB0 - DB3) are transferred. So transfer is performed by two times. Busy flag outputs "High" after the second transfer are ended.
- When interfacing data length are 8-bit, transfer is performed at a time through 8 ports, from DB0 - DB7.
- If IM is set to "Low", serial transfer mode is set.

INTERFACE WITH MPU IN BUS MODE

Interface with 8-bit MPU

If 8-bit MPU is used, S6A0075 can connect directly with that. In this case, port E, RS, R/W and DB0 - DB7 need to interface each other. Example of timing sequence is shown below.

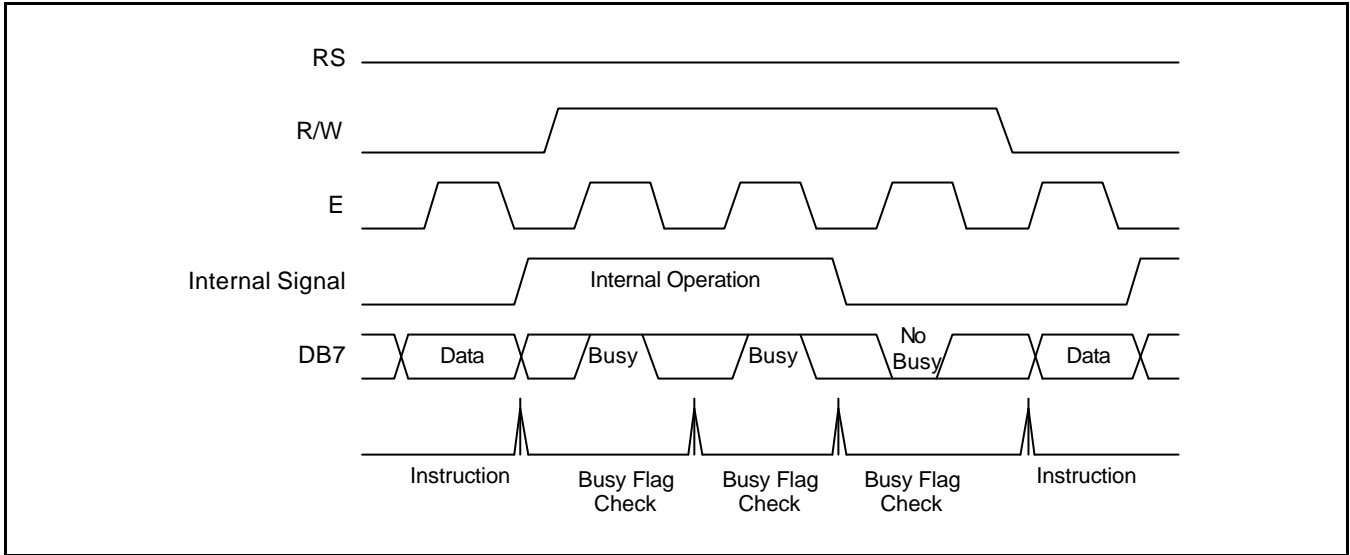

Figure 11. Example of 8-bit Bus Mode Timing Sequence

Interface with 4-bit MPU

If 4-bit MPU is used, S6A0075 can connect directly with this. In this case, port E, RS, R/W and DB4 - DB7 need to interface each other. The transfer is performed by two times. Example of timing sequence is shown below.

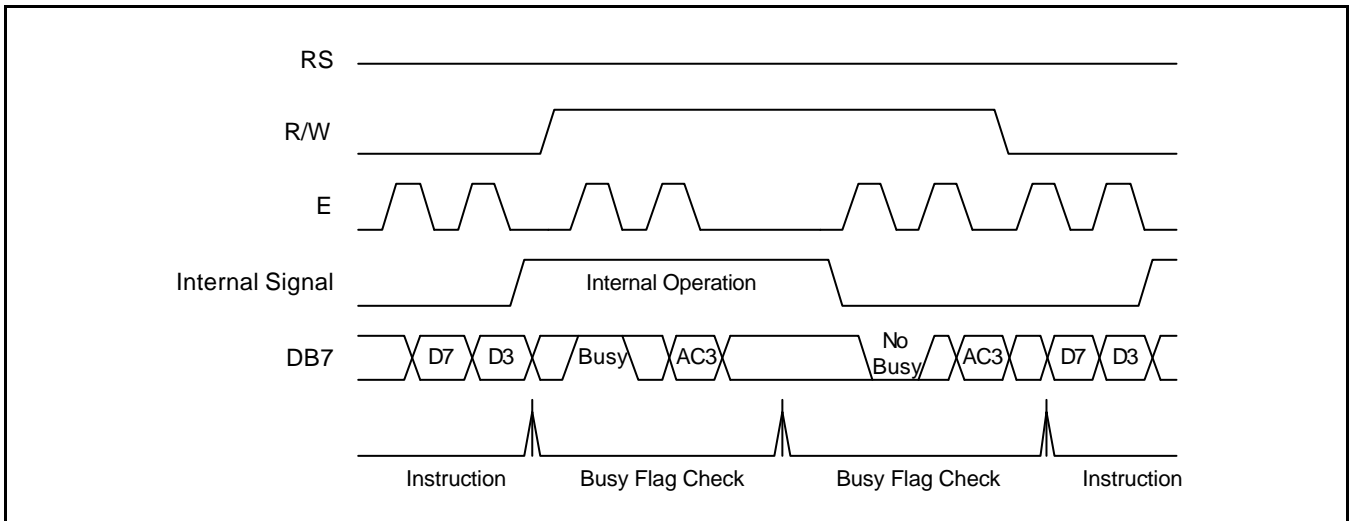

Figure 12. Example of 4-bit Bus Mode Timing Sequence

INTERFACE WITH MPU IN SERIAL MODE

When IM port input is "Low", serial interface mode is started. At this time, all three ports, SCLK (synchronizing transfer clock), SID (serial input data), and SOD (serial output data), are used. If you want to use S6A0075 with other chips, chip select port (CS) can be used. By setting CS to "Low", S6A0075 can receive SCLK input. If CS is set to "High", S6A0075 reset the internal transfer counter.

Before transfer real data, start byte has to be transferred. It is composed of succeeding 5 "High" bits, read write control bit (R/W), register selection bit (RS), and end bit that indicates the end of start byte. Whenever succeeding 5 "High" bits are detected by S6A0075, it makes serial transfer counter reset and ready to receive next information.

The next input data are register selection bit that determine which register will be used, and read write control bit that determine the direction of data. Then end bit is transferred, which must have "Low" value to show the end of start byte. (Refer to Figure 13. Figure 14)

Write Operation (R/W = 0)

After start byte is transferred from MPU to S6A0075, 8-bit data is transferred which is divided into 2 bytes, each byte has 4 bit's real data and 4 bit's partition token data. For example, if real data is "10110001" (D0 - D7), then serially transferred data becomes "1011 0000 0001 0000" where 2nd and 4th 4 bits must be "0000" for safe transfer. To transfer several bytes continuously without changing RS bit and RW bit, start byte transfer is needed only at first starting time. Namely, after first start byte is transferred, real data can be transferred succeeding.

Read Operation (R/W = 1)

After start byte is transferred to S6A0075, MPU can receive 8-bit data through the SOD port at a time from the LSB. Wait time is needed to insert between start byte and data reading, because internal reading from RAM requires some delay. Continuous data reading is possible like serial write operation. It also needs only one start bytes, only if you insert some delay between reading operations of each byte. During the reading operation, S6A0075 observes succeeding 5 "High" from MPU. If it is detected, S6A0075 restarts serial operation at once and ready to receive RS bit. So in continuous reading operation, SID port must be "Low".

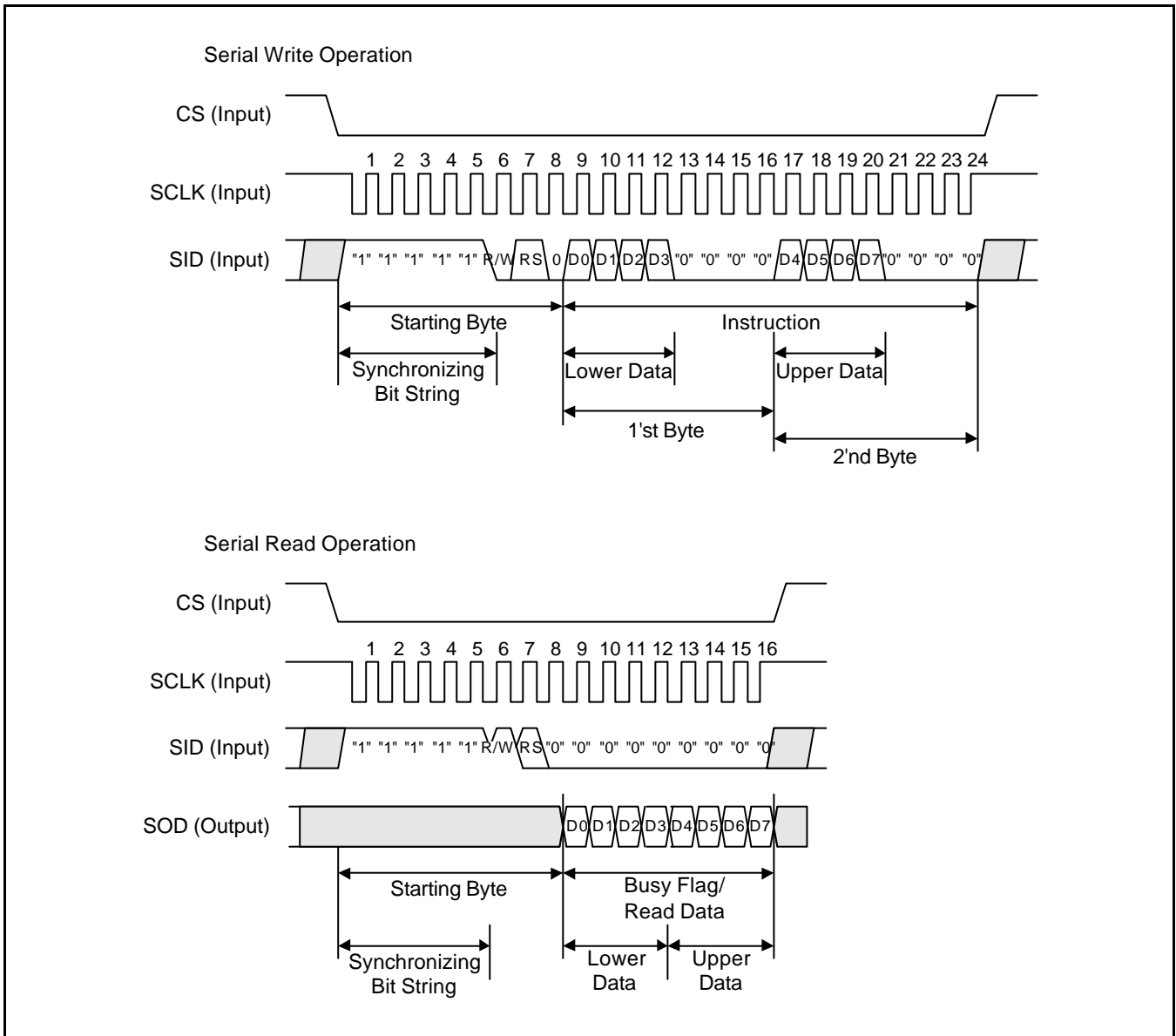

Figure 13. Timing Diagram of Serial Data Transfer

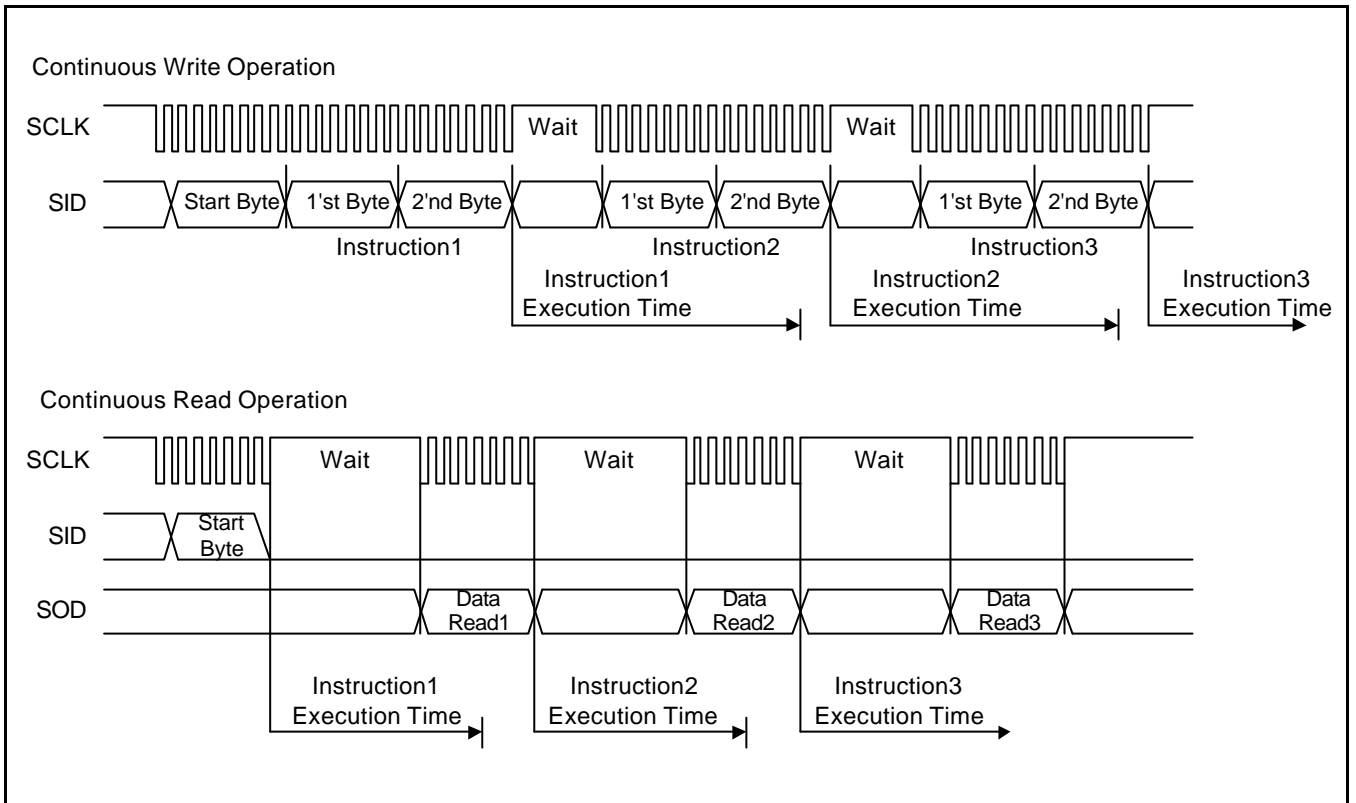
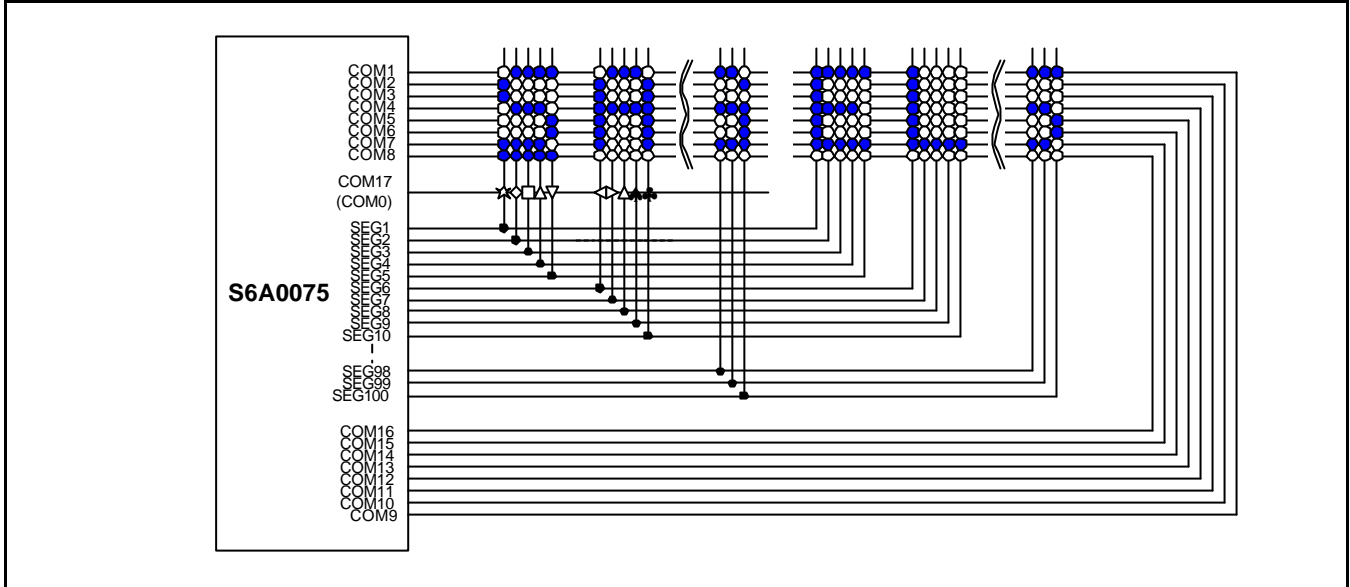

Figure 14. Timing Diagram of Continuous Data Transfer

APPLICATION INFORMATION ACCORDING TO LCD PANEL

LCD Panel: 40 Character x 1-line Format (5-dot Font, 1/17 Duty)



LCD Panel: 40 Character x 2-line Format (5-dot Font, 1/33 Duty)

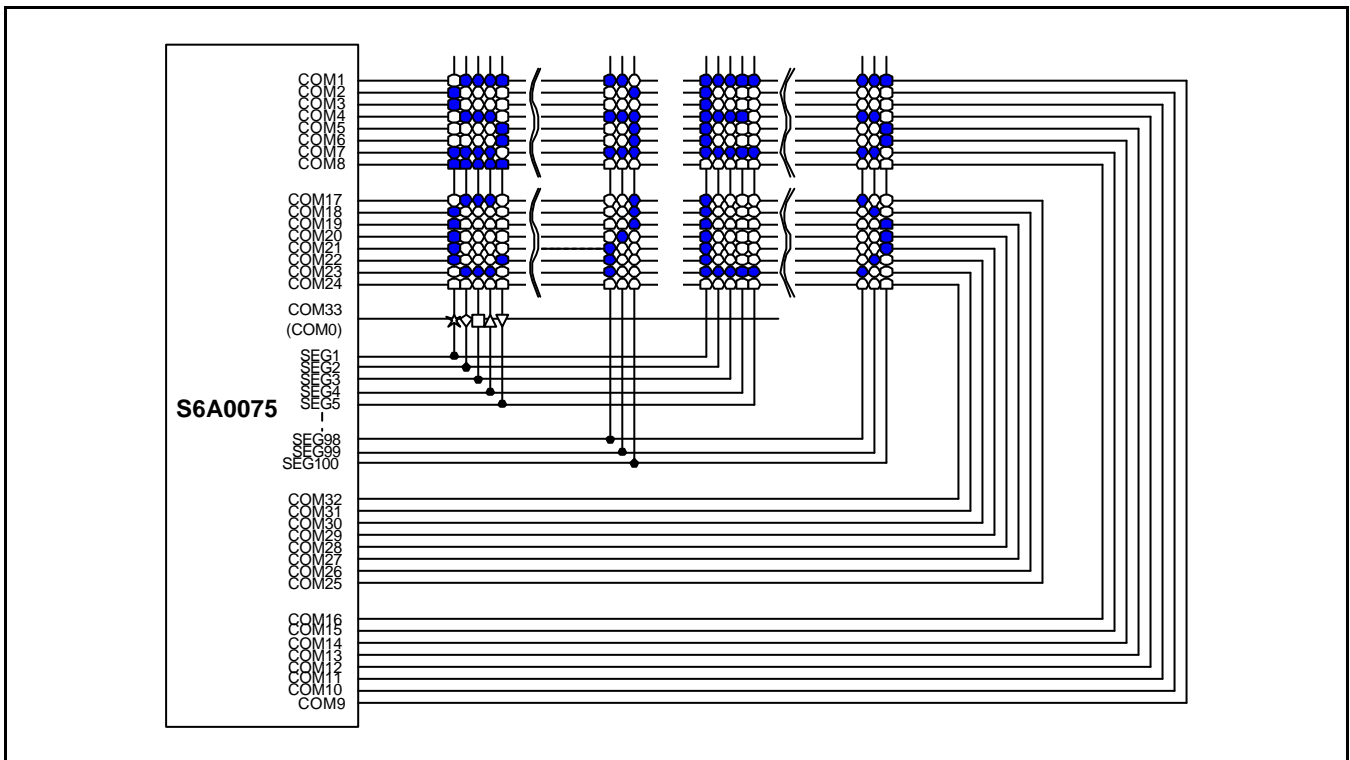

LCD Panel: 20 Character x 4-line Format (5-dot Font, 1/33 Duty)

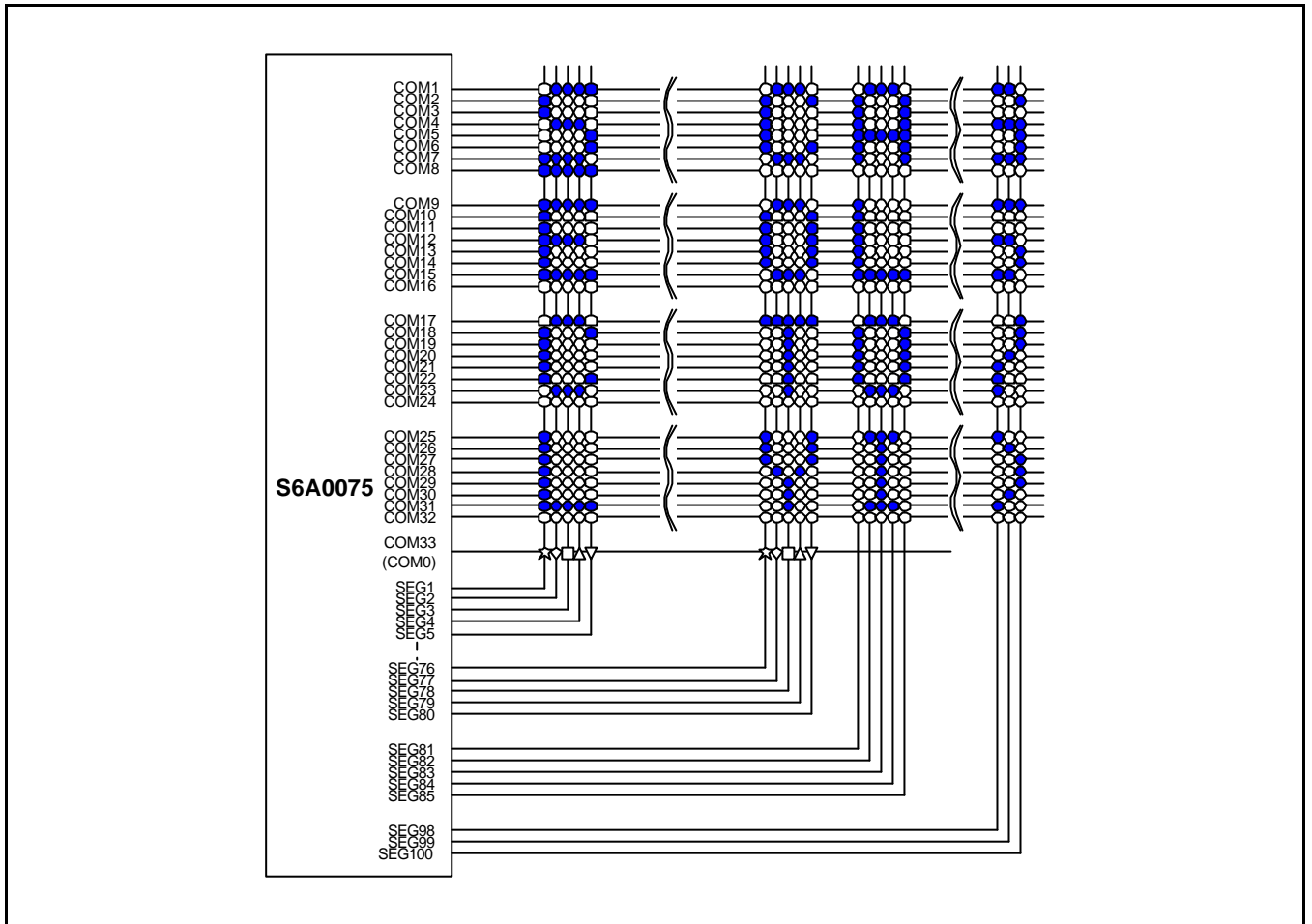

LCD Panel: 16 Character x 4-line Format (6-dot Font, 1/33 Duty)

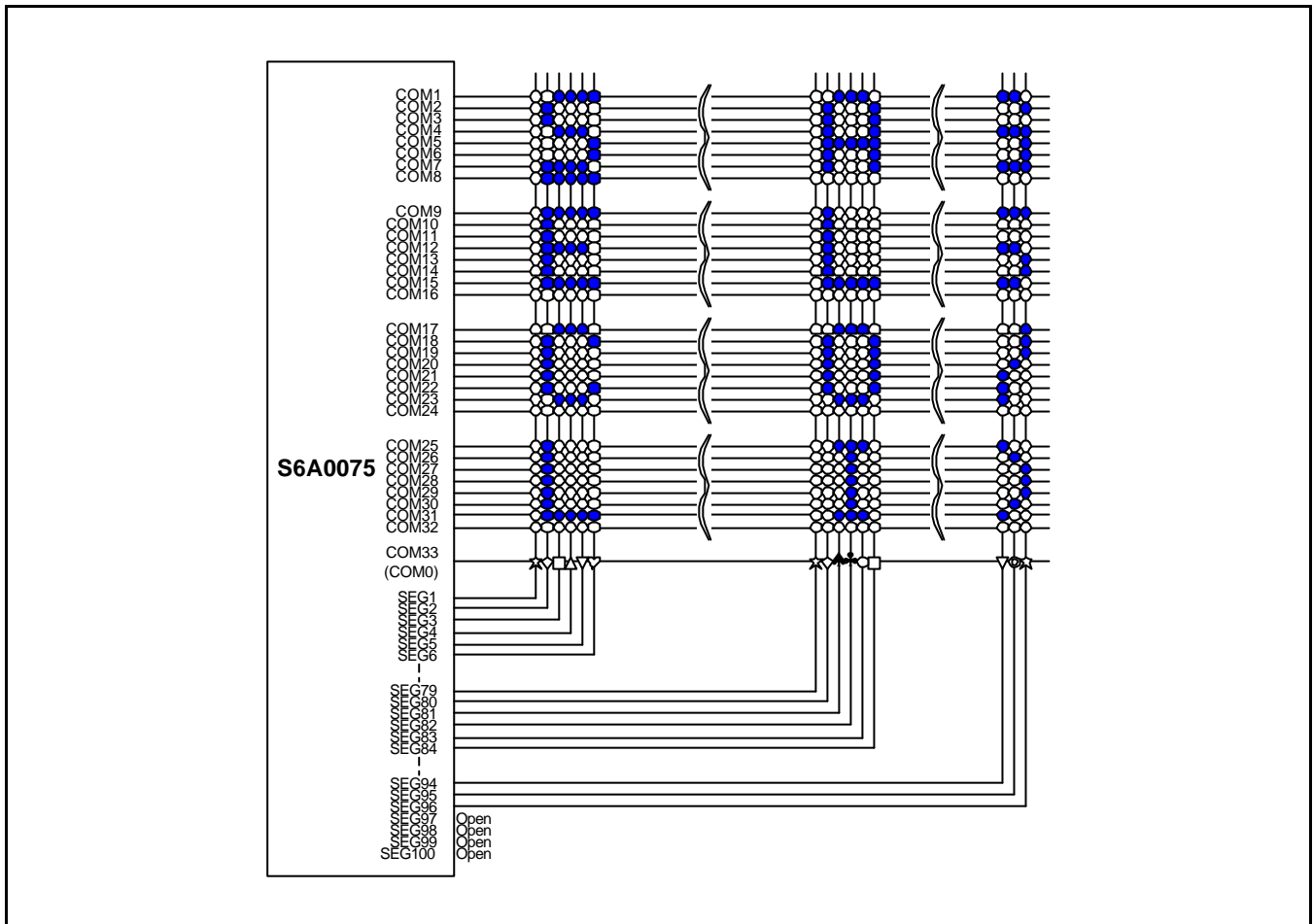

INITIALIZING

INITIALIZING BY INTERNAL RESET CIRCUIT

When the power is turned on, S6A0075 is initialized automatically by power on reset circuit. During the initialization, the following instructions are executed, and BF(Busy Flag) is kept "High"(busy state) to the end of initialization.

Display Clear instruction

Write "20H" to all DDRAM

Set Functions instruction

DL = 1: 8-bit bus mode
N = 1: 2-line display mode
RE = 0: Extension register disable
BE = 0: CGRAM/SEGRAM blink OFF
DH = 0: Horizontal scroll enable
REV = 0: Normal display (Not reversed display)

Control Display ON/OFF instruction

D = 0: Display OFF
C = 0: Cursor OFF
B = 0: Blink OFF

Set Entry Mode instruction

I/D = 1: Increment by 1
S = 0: No entire display shift
BID = 0: Normal direction segment port

Set Extension Function instruction

FW = 0: 5-dot font width character display
B/W = 0: Normal cursor (8th line)
NW = 0: Not 4-line display mode, 2-line mode is set because of N("1")

Enable Shift instruction

HS = 0000: Scroll per line disable
DS = 0000: Shift per line disable

Set scroll Quantity instruction

SQ = 000000: Not scroll

INITIALIZING BY HARDWARE RESET INPUT

When RESET pin = "Low", S6A0075 can be initialized like the case of power on reset. During the power on reset operation, this pin is ignored.

INITIALIZING BY INSTRUCTION

8-BIT INTERFACE MODE

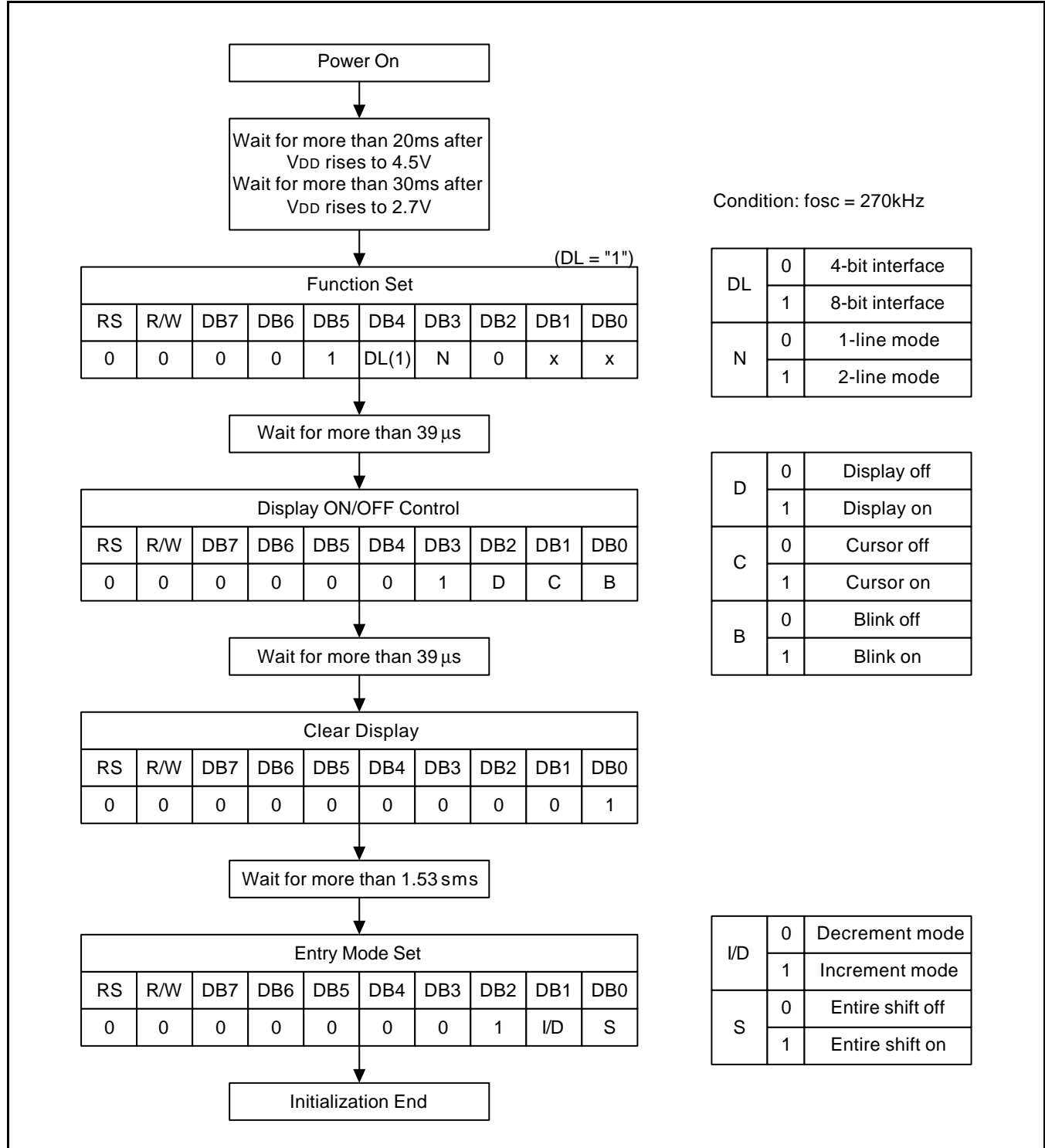

4-BIT INTERFACE MODE

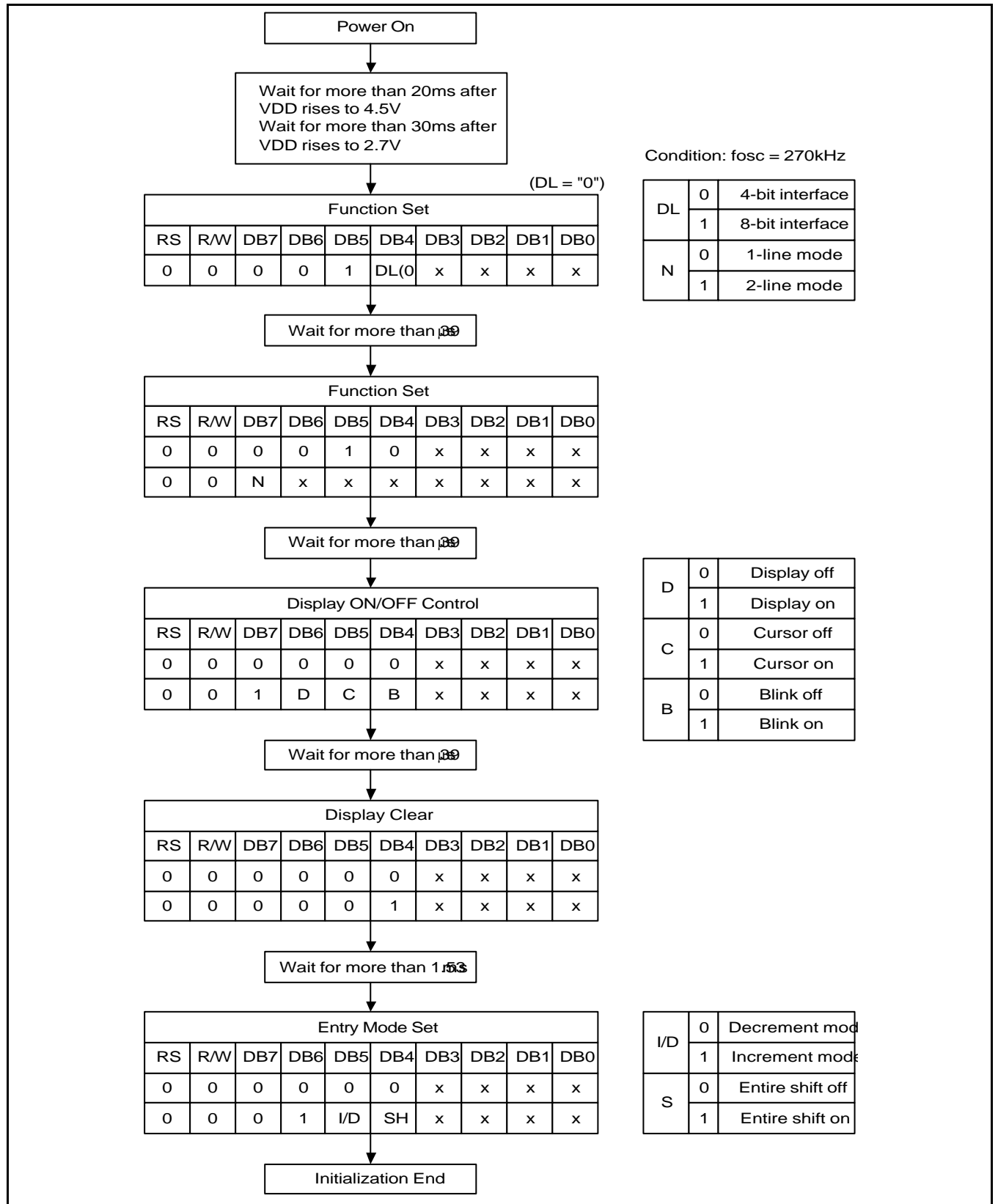

EXAMPLE OF INSTRUCTION AND DISPLAY CORRESPONDENCE

IE = "LOW"

										LCD DISPLAY
1. Power supply on: Initialized by the internal power on reset circuit										
RS	R/W	DB7	DB6	DB5	DB4	DB3	DB2	DB1	DB0	
2. Function Set: 8-bit, 1-line, RE(0)										
RS	R/W	DB7	DB6	DB5	DB4	DB3	DB2	DB1	DB0	
0	0	0	0	1	1	1	0	X	X	
3. Display ON/OFF Control: Display/Cursor on										
RS	R/W	DB7	DB6	DB5	DB4	DB3	DB2	DB1	DB0	
0	0	0	0	0	0	1	1	1	0	-
4. Entry Mode Set: Increment										
RS	R/W	DB7	DB6	DB5	DB4	DB3	DB2	DB1	DB0	
0	0	0	0	0	0	0	1	1	0	-
5. Write Data to DDRAM: Write S										
RS	R/W	DB7	DB6	DB5	DB4	DB3	DB2	DB1	DB0	
1	0	0	1	0	1	0	0	1	1	S_
6. Write Data to DDRAM: Write A										
RS	R/W	DB7	DB6	DB5	DB4	DB3	DB2	DB1	DB0	
1	0	0	1	0	0	0	0	0	1	SA_
7. Write Data to DDRAM: Write M										
RS	R/W	DB7	DB6	DB5	DB4	DB3	DB2	DB1	DB0	
1	0	0	1	0	0	1	1	0	1	SAM_
8. Write Data to DDRAM: Write S										
RS	R/W	DB7	DB6	DB5	DB4	DB3	DB2	DB1	DB0	
1	0	0	1	0	1	0	0	1	1	SAMS_

9. Write Data to DDRAM: Write U

RS	R/W	DB7	DB6	DB5	DB4	DB3	DB2	DB1	DB0
1	0	0	1	0	1	0	1	0	1

LCD DISPLAY

SAMSU_

10. Write Data to DDRAM: Write N

RS	R/W	DB7	DB6	DB5	DB4	DB3	DB2	DB1	DB0
1	0	0	1	0	0	1	1	1	0

SAMSUN_

11. Write Data to DDRAM: Write G

RS	R/W	DB7	DB6	DB5	DB4	DB3	DB2	DB1	DB0
1	0	0	1	0	0	0	1	1	1

SAMSUNG_

12. Cursor or Display Shift: Cursor shift to right

RS	R/W	DB7	DB6	DB5	DB4	DB3	DB2	DB1	DB0
0	0	0	0	0	1	0	1	X	X

SAMSUNG_

13. Entry Mode Set: Entire Display Shift Enable

RS	R/W	DB7	DB6	DB5	DB4	DB3	DB2	DB1	DB0
0	0	0	0	0	0	0	1	1	1

SAMSUNG_

14. Write Data to DDRAM: Write S

RS	R/W	DB7	DB6	DB5	DB4	DB3	DB2	DB1	DB0
1	0	0	1	1	0	0	0	1	1

AMSUNG S_

15. Write Data to DDRAM: Write 6

RS	R/W	DB7	DB6	DB5	DB4	DB3	DB2	DB1	DB0
1	0	0	0	1	1	0	1	1	0

MSUNG S6_

16. Write Data to DDRAM: Write A

RS	R/W	DB7	DB6	DB5	DB4	DB3	DB2	DB1	DB0
1	0	0	1	0	0	0	0	0	1

SUNG S6A_



17. Write Data to DDRAM: Write 0

RS	R/W	DB7	DB6	DB5	DB4	DB3	DB2	DB1	DB0
1	0	0	0	1	1	0	0	0	0

LCD DISPLAY

UNG S6A0_

18. Write Data to DDRAM: Write 0

RS	R/W	DB7	DB6	DB5	DB4	DB3	DB2	DB1	DB0
1	0	0	0	1	1	0	1	1	1

NG S6A00_

19. Write Data to DDRAM: Write 7

RS	R/W	DB7	DB6	DB5	DB4	DB3	DB2	DB1	DB0
1	0	0	0	1	1	0	1	1	1

G S6A007_

20. Write Data to DDRAM: Write 3

RS	R/W	DB7	DB6	DB5	DB4	DB3	DB2	DB1	DB0
1	0	0	0	1	1	0	0	1	1

G S6A0073_

21. Cursor or Display Shift: Cursor shift left

RS	R/W	DB7	DB6	DB5	DB4	DB3	DB2	DB1	DB0
0	0	0	0	0	1	0	0	x	x

G S6A007 3

22. Write Data to DDRAM: Write 5

RS	R/W	DB7	DB6	DB5	DB4	DB3	DB2	DB1	DB0
1	0	0	0	1	1	0	1	0	1

S6A0075_

23. Return Home

RS	R/W	DB7	DB6	DB5	DB4	DB3	DB2	DB1	DB0
0	0	0	0	0	0	0	0	1	x

SAMSUNG S6A0075

24. Clear Display

RS	R/W	DB7	DB6	DB5	DB4	DB3	DB2	DB1	DB0
0	0	0	0	0	0	0	0	0	1

_

IE = "HIGH"

1. Power Supply On: Initialized by the internal power on reset circuit

RS	R/W	DB7	DB6	DB5	DB4	DB3	DB2	DB1	DB0

2. Function Set: 8-bit, RE(1)

RS	R/W	DB7	DB6	DB5	DB4	DB3	DB2	DB1	DB0
0	0	0	0	1	1	1	1	0	0

3. Extended Function Set: 5-font, 4-line

RS	R/W	DB7	DB6	DB5	DB4	DB3	DB2	DB1	DB0
0	0	0	0	0	0	1	0	0	1

4. Function Set: RE(0)

RS	R/W	DB7	DB6	DB5	DB4	DB3	DB2	DB1	DB0
0	0	0	0	1	1	1	0	0	0

5. Display ON/OFF Control: Display/Cursor on

RS	R/W	DB7	DB6	DB5	DB4	DB3	DB2	DB1	DB0
0	0	0	0	0	0	1	1	1	0

_

6. Write Data to DDRAM: Write S

RS	R/W	DB7	DB6	DB5	DB4	DB3	DB2	DB1	DB0
1	0	0	1	0	1	0	0	1	1

S_

7. Write Data to DDRAM: Write A

RS	R/W	DB7	DB6	DB5	DB4	DB3	DB2	DB1	DB0
1	0	0	1	0	0	0	0	0	1

SAMSUNG
SA_

12. Write Data to DDRAM: Write G

RS	R/W	DB7	DB6	DB5	DB4	DB3	DB2	DB1	DB0
1	0	0	1	0	0	0	1	1	1

SAMSUNG
G_

13. Set DDRAM Address 20H

RS	R/W	DB7	DB6	DB5	DB4	DB3	DB2	DB1	DB0
0	0	1	0	1	0	0	0	0	0

SAMSUNG
20H

14. Write Data to DDRAM: Write S

RS	R/W	DB7	DB6	DB5	DB4	DB3	DB2	DB1	DB0
1	0	0	1	0	1	0	0	1	1

SAMSUNG
S_

20. Write Data to DDRAM: Write 5

RS	R/W	DB7	DB6	DB5	DB4	DB3	DB2	DB1	DB0
1	0	0	0	1	1	0	1	0	1

SAMSUNG
S6A0075_

21. Set DDRAM Address 40H

RS	R/W	DB7	DB6	DB5	DB4	DB3	DB2	DB1	DB0
0	0	1	1	0	0	0	0	0	0

SAMSUNG
S6A0075
40H

21. Write Data to DDRAM: Write L

RS	R/W	DB7	DB6	DB5	DB4	DB3	DB2	DB1	DB0
1	0	0	1	0	0	1	1	0	0

SAMSUNG
S6A0075
L_

30. Write Data to DDRAM: Write R

RS	R/W	DB7	DB6	DB5	DB4	DB3	DB2	DB1	DB0
1	0	0	1	0	1	0	0	1	0

SAMSUNG
S6A0075
LCD DRIVER_

31. Set DDRAM Address 60H

RS	R/W	DB7	DB6	DB5	DB4	DB3	DB2	DB1	DB0
0	0	1	1	1	0	0	0	0	0

SAMSUNG
S6A0075
LCD DRIVER
_

43. Write Data to DDRAM: Write R

RS	R/W	DB7	DB6	DB5	DB4	DB3	DB2	DB1	DB0
1	0	0	1	0	1	0	0	1	0

SAMSUNG
S6A0075
LCD DRIVER
& CONTROLLER_

44. Function Set: RE("0"), DH("1")

RS	R/W	DB7	DB6	DB5	DB4	DB3	DB2	DB1	DB0
0	0	0	0	1	1	1	0	1	0

SAMSUNG
S6A0075
LCD DRIVER
& CONTROLLER_

45. Function Set: RE("1")

RS	R/W	DB7	DB6	DB5	DB4	DB3	DB2	DB1	DB0
0	0	0	0	1	1	1	1	0	0

SAMSUNG
S6A0075
LCD DRIVER
& CONTROLLER_

46. Shift/Scroll Enable: DS4("1"), DS3/2/1("0")

RS	R/W	DB7	DB6	DB5	DB4	DB3	DB2	DB1	DB0
0	0	0	0	0	1	1	0	0	0

SAMSUNG
S6A0075
LCD DRIVER
& CONTROLLER_

47. Function Set: RE("0")

RS	R/W	DB7	DB6	DB5	DB4	DB3	DB2	DB1	DB0
0	0	0	0	1	1	1	0	1	0

SAMSUNG
S6A0075
LCD DRIVER
& CONTROLLER_

48. Cursor or Display Shift: Display shift to left

RS	R/W	DB7	DB6	DB5	DB4	DB3	DB2	DB1	DB0
0	0	0	0	0	1	1	0	x	x

SAMSUNG
S6A0075
LCD DRIVER
CONTROLLER_

49. Cursor or Display Shift: Display shift to left

RS	R/W	DB7	DB6	DB5	DB4	DB3	DB2	DB1	DB0
0	0	0	0	0	1	1	0	x	x

SAMSUNG
S6A0075
LCD DRIVER
CONTROLLER_

50. Cursor or Display Shift: Display shift to left

RS	R/W	DB7	DB6	DB5	DB4	DB3	DB2	DB1	DB0
0	0	0	0	0	1	1	0	x	x

SAMSUNG
S6A0075
LCD DRIVER
ONTROLLER_

51. Cursor or Display Shift: Display shift to left

RS	R/W	DB7	DB6	DB5	DB4	DB3	DB2	DB1	DB0
0	0	0	0	0	1	1	0	x	x

SAMSUNG
S6A0075
LCD DRIVER
NTROLLER_

52. Return Home

RS	R/W	DB7	DB6	DB5	DB4	DB3	DB2	DB1	DB0
0	0	0	0	0	0	0	0	1	x

**SAMSUNG
S6A0075
LCD DRIVER
& CONTROLLER**

53. Function Set: RE("0), REV("1")

RS	R/W	DB7	DB6	DB5	DB4	DB3	DB2	DB1	DB0
0	0	0	0	1	1	1	0	1	1

**SAMSUNG
S6A0075
LCD DRIVER
& CONTROLLER**

54. Cursor or Display Shift: Display shift to right

RS	R/W	DB7	DB6	DB5	DB4	DB3	DB2	DB1	DB0
0	0	0	0	0	1	1	1	x	x

**SAMSUNG
S6A0075
LCD DRIVER
& CONTROLLER**

55. Cursor or Display Shift: Display shift to right

RS	R/W	DB7	DB6	DB5	DB4	DB3	DB2	DB1	DB0
0	0	0	0	0	1	1	1	x	x

**SAMSUNG
S6A0075
LCD DRIVER
& CONTROLLER**

56. Return Home

RS	R/W	DB7	DB6	DB5	DB4	DB3	DB2	DB1	DB0
0	0	0	0	0	0	0	0	1	x

**SAMSUNG
S6A0075
LCD DRIVER
& CONTROLLER**

57. Function Set: RE("0"), REV("0")

RS	R/W	DB7	DB6	DB5	DB4	DB3	DB2	DB1	DB0
0	0	0	0	1	1	1	0	0	0

**SAMSUNG
S6A0075
LCD DRIVER
& CONTROLLER**

58. Function Set: RE("1")

RS	R/W	DB7	DB6	DB5	DB4	DB3	DB2	DB1	DB0
0	0	0	0	1	1	1	1	0	0

SAMSUNG
S6A0075
LCD DRIVER
& CONTROLLER

59. Entry Mode Set: BID("1")

RS	R/W	DB7	DB6	DB5	DB4	DB3	DB2	DB1	DB0
0	0	0	0	0	0	0	1	1	1

SAMSUNG
S6A0075
LCD DRIVER
& CONTROLLER

60. Clear Display

RS	R/W	DB7	DB6	DB5	DB4	DB3	DB2	DB1	DB0
1	0	0	1	0	0	0	0	1	0

—

61. Write Data to DDRAM: Write B

RS	R/W	DB7	DB6	DB5	DB4	DB3	DB2	DB1	DB0
1	0	0	1	0	0	1	0	0	1

B_

62. Write Data to DDRAM: Write I

RS	R/W	DB7	DB6	DB5	DB4	DB3	DB2	DB1	DB0
1	0	0	1	0	0	0	1	0	0

BI_

63. Write Data for DDRAM: Write D

RS	R/W	DB7	DB6	DB5	DB4	DB3	DB2	DB1	DB0
0	0	0	0	0	0	0	0	0	1

BID_

FRAME FREQUENCY

1/17 DUTY CYCLE

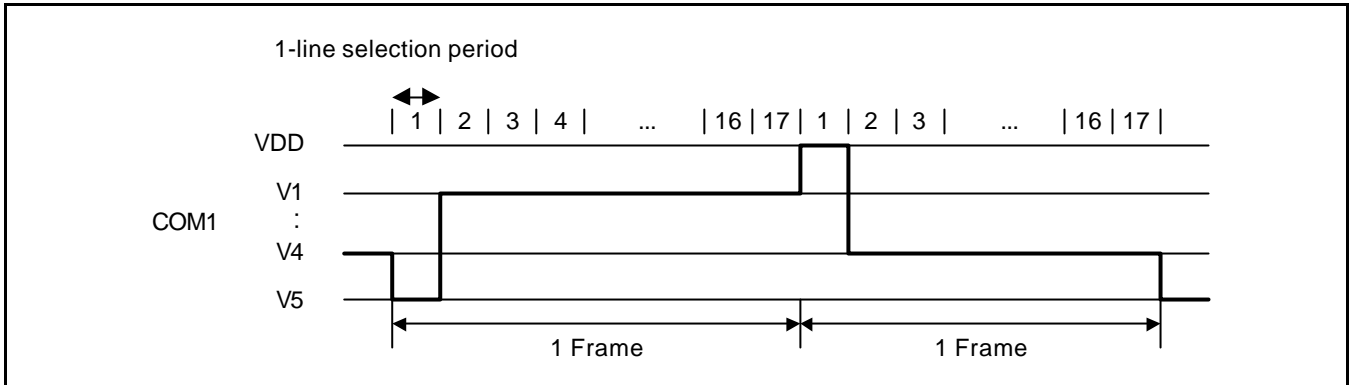

Item	Display Font Width	
	5-Dot Font Width	6-Dot Font Width
1-line selection period	200 clocks	240 clocks
Frame frequency	79.4Hz	66.2Hz

NOTE: $f_{OSC} = 270\text{kHz}$ (1 clock = $3.7\mu\text{s}$)

1/33 DUTY CYCLE

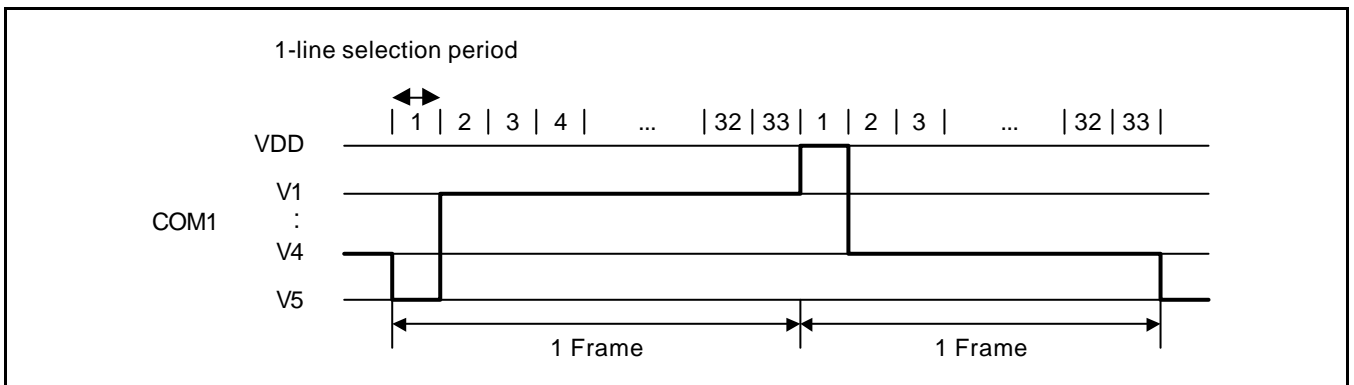

Item	Display Font Width	
	5-Dot Font Width	6-Dot Font Width
1-line selection period	100 clocks	120 clocks
Frame frequency	81.8Hz	68.2Hz

NOTE: $f_{OSC} = 270\text{kHz}$ (1 clock = $3.7\mu\text{s}$)

POWER SUPPLY FOR DRIVING LCD PANEL

WHEN AN EXTERNAL POWER SUPPLY IS USED

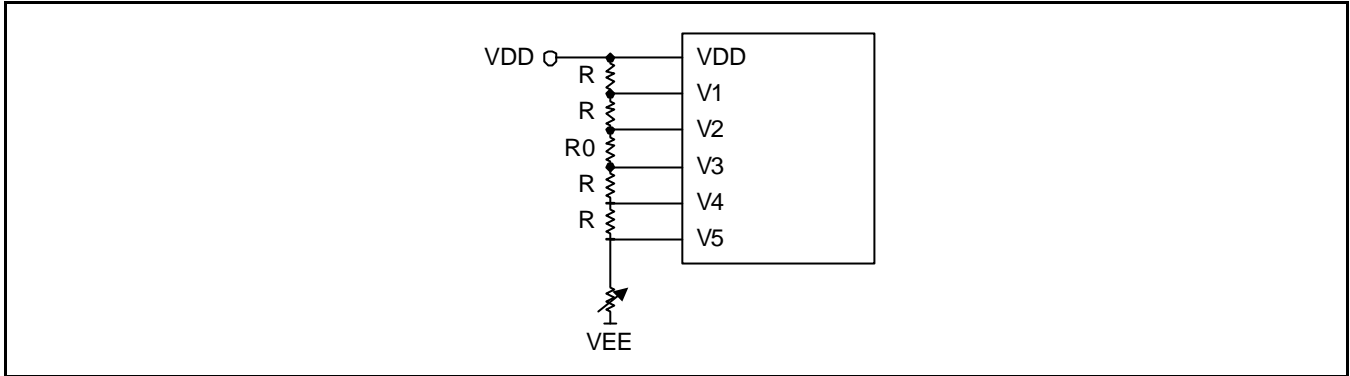

WHEN AN INTERNAL BOOSTER IS USED

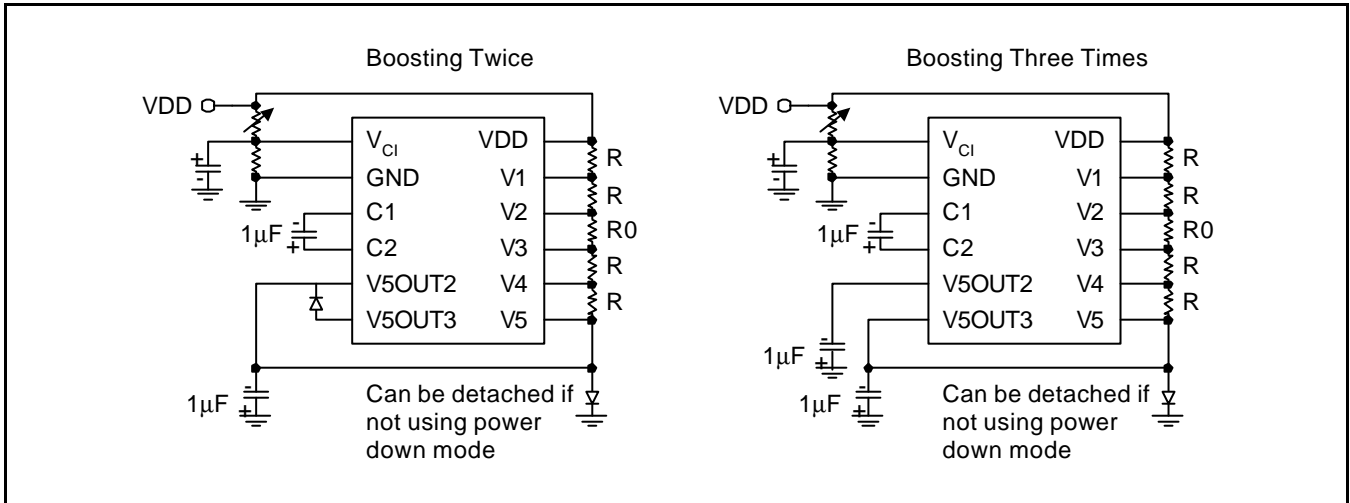

- Boosted output voltage should not exceed the maximum value (13 V) of the LCD driving voltage. Especially, a voltage of over 4.3V should not be input to the reference voltage (Vci) when boosting three times.
- A voltage of over 5.5V should not be input to the reference voltage (Vci) when boosting twice.
- The value of resistance, according to the number of lines, duty ratio and the bias, is shown below. (refer to Table 13)

Table 13. Duty Ratio and Power Supply for LCD Driving

Item		Data	
Number of lines		1	2 or 4
Duty ratio		1/17	1/33
Bias		1/5	1/6.7
Divided resistance	R	R	R
	R0	R	2.7R

MAXIMUM ABSOLUTE RATE

Characteristic	Symbol	Value	Unit
Power supply voltage (1)	V_{DD}	-0.3 to +7.0	V
Power supply voltage (2)	V_{LCD}	$V_{DD} - 15.0$ to $V_{DD} + 0.3$	V
Input voltage	V_{IN}	-0.3 to $V_{DD} + 0.3$	V
Operating temperature	T_{OPR}	-30 to +85	°C
Storage temperature	T_{STG}	-55 to +125	°C

NOTE: Voltage greater than above may damage to the circuit ($V_{DD} \geq V1 \geq V2 \geq V3 \geq V4 \geq V5$)

ELECTRICAL CHARACTERISTICS

DC CHARACTERISTICS

($V_{DD} = 2.7V$ to $5.5V$, $T_A = -30$ to $+85^\circ C$)

Characteristic	Symbol	Condition	Min	Typ	Max	Unit	
Operating voltage	V_{DD}	–	2.7	–	5.5	V	
Supply current	I_{DD}	Internal oscillation or external clock. ($V_{DD} = 3.0V$, $f_{OSC} = 270kHz$)	–	0.15	0.3	mA	
Input voltage (1) (Except OSC1)	V_{IH1}	–	$0.7V_{DD}$	–	V_{DD}	–	
	V_{IL1}	$V_{DD} = 2.7 - 3.0$	-0.3	–	$0.2V_{DD}$		
		$V_{DD} = 3.0 - 5.5$	-0.3	–	0.6		
Input voltage (2) (OSC1)	V_{IH2}	–	$0.7V_{DD}$	–	V_{DD}	V	
	V_{IL2}	–	–	–	$0.2V_{DD}$		
Output voltage (1) (DB0 - DB7)	V_{OH1}	$I_{OH} = -0.1mA$	$0.75V_{DD}$	–	–	V	
	V_{OL1}	$I_{OL} = 0.1mA$	–	–	$0.2V_{DD}$		
Output voltage (2) (Except DB0 - DB7)	V_{OH2}	$I_O = -40\mu A$	$0.8V_{DD}$	–	–	V	
	V_{OL1}	$I_O = 40\mu A$	–	–	$0.2V_{DD}$		
Voltage drop	V_{dCOM}	$I_O = \pm 0.1mA$	–	–	1	V	
	V_{dSEG}		–	–	1		
Input leakage current	I_{LKG}	$V_{IN} = 0V - V_{DD}$	-1	–	1	μA	
Low input current	I_{IL}	$V_{IN} = 0V$, $V_{DD} = 3V$ (pull up)	-10	-50	-120		
Internal clock (external Rf)	f_{OSC}	$R_f = 91k\Omega \pm 2\%$ ($V_{DD} = 5V$)	190	270	350	kHz	
External clock	f_{EC}	–	125	270	410	kHz	
	duty		45	50	55	%	
	tr, tf		–	–	0.2	μs	
Voltage converter out2 ($V_{ci} = 4.5V$)	V_{OUT2}	$T_A = 25^\circ C$, $C = 1\mu F$, $I_{OUT} = 0.25mA$, $f_{OSC} = 270kHz$	-3.0	-4.2	–	V	
Voltage converter out3 ($V_{ci} = 2.7V$)			V_{OUT3}	-4.3	-5.1		–
Voltage converter input	V_{ci}	–	1.0	–	4.5	V	
LCD driving voltage	V_{LCD}	$V_{DD} - V_5$	1/5 bias	3.0	–	13.0	
			1/6.7 bias	3.0	–	13.0	

AC CHARACTERISTICS $(V_{DD} = 4.5 \text{ to } 5.5\text{V}, T_A = -30 \text{ to } +85^\circ\text{C})$

Mode	Item	Symbol	Min	Typ	Max	Unit
(1) Write mode (refer to Figure15)	E cycle time	tc	500	–	–	ns
	E rise/fall time	tr, tf	–	–	20	
	E pulse width (high, low)	tw	230	–	–	
	R/W and RS setup time	tsu1	40	–	–	
	R/W and RS hold time	th1	10	–	–	
	Data setup time	tsu2	60	–	–	
	Data hold time	th2	10	–	–	
(2) Read mode (refer to Figure 16)	E cycle time	tc	500	–	–	ns
	E rise/fall time	tr, tf	–	–	20	
	E pulse width (high, low)	tw	230	–	–	
	R/W and RS setup time	tsu	40	–	–	
	R/W and RS hold time	th	10	–	–	
	Data output delay time	t _D	–	–	160	
	Data hold time	t _{DH}	5	–	–	
(3) Serial interface mode (refer to Figure 17)	Serial clock cycle time	tc	0.5	–	20	μs
	Serial clock rise/fall time	tr, tf	–	–	50	ns
	Serial clock width (high, low)	tw	200	–	–	
	Chip select setup time	tsu1	60	–	–	
	Chip select hold time	th ₁	20	–	–	
	Serial input data setup time	tsu2	100	–	–	
	Serial input data hold time	th2	100	–	–	
	Serial output data delay time	t _D	–	–	160	
	Serial output data hold time	t _{DH}	5	–	–	

($V_{DD} = 2.7$ to $4.5V$, $T_A = -30$ to $+85^\circ C$)

Mode	Item	Symbol	Min	Typ	Max	Unit
(4) Write mode (refer to Figure 15)	E cycle time	t_c ,	1000	–	–	ns
	E rise/fall time	t_r, t_f	–	–	25	
	E pulse width (high, low)	t_w	450	–	–	
	R/W and RS setup time	t_{su1}	60	–	–	
	R/W and RS hold time	t_{h1}	20	–	–	
	Data setup time	t_{su2}	195	–	–	
	Data hold time	t_{h2}	10	–	–	
(5) Read mode (refer to Figure 16)	E cycle time	t_c	1000	–	–	ns
	E rise/fall time	t_r, t_f	–	–	25	
	E pulse width (high, low)	t_w	450	–	–	
	R/W and RS setup time	t_{su}	60	–	–	
	R/W and RS hold time	t_h	20	–	–	
	Data output delay time	t_D	–	–	360	
	Data hold time	t_{DH}	5	–	–	
(6) Serial interface mode (refer to Figure 17)	Serial clock cycle time	t_c	1	–	20	μs
	Serial clock rise/fall time	t_r, t_f	–	–	50	ns
	Serial clock width (high, low)	t_w	400	–	–	
	Chip select setup time	t_{su1}	60	–	–	
	Chip select hold time	t_{h1}	20	–	–	
	Serial input data setup time	t_{su2}	200	–	–	
	Serial input data hold time	t_{h2}	200	–	–	
	Serial output data delay time	t_D	–	–	360	
	Serial output data hold time	t_{DH}	5	–	–	

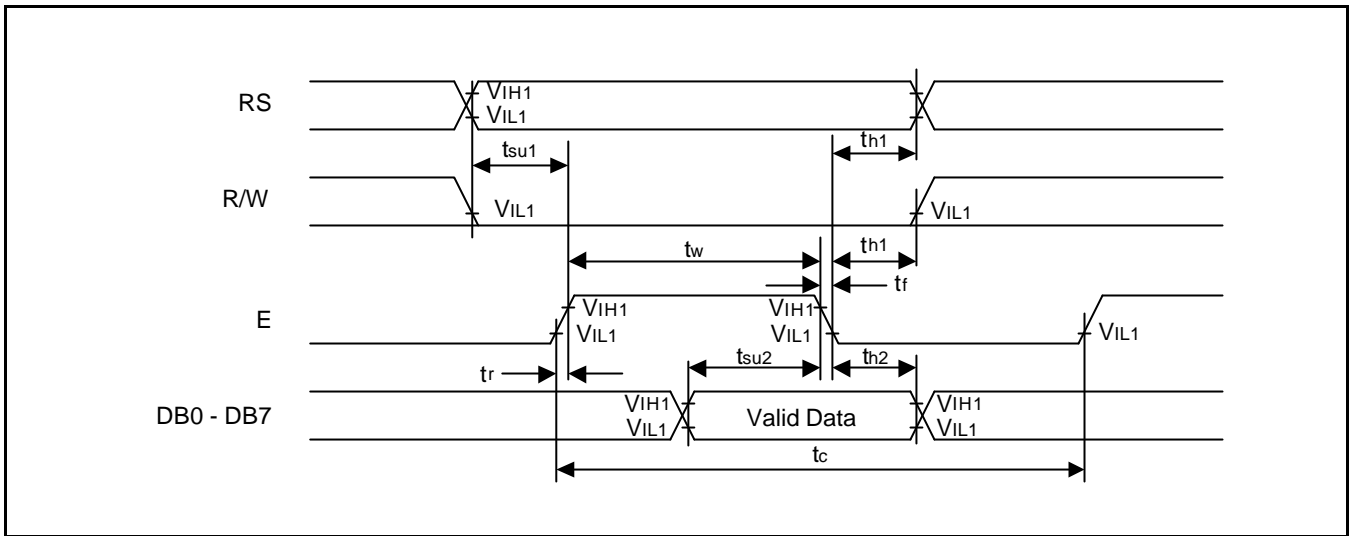

Figure 15. Write Mode

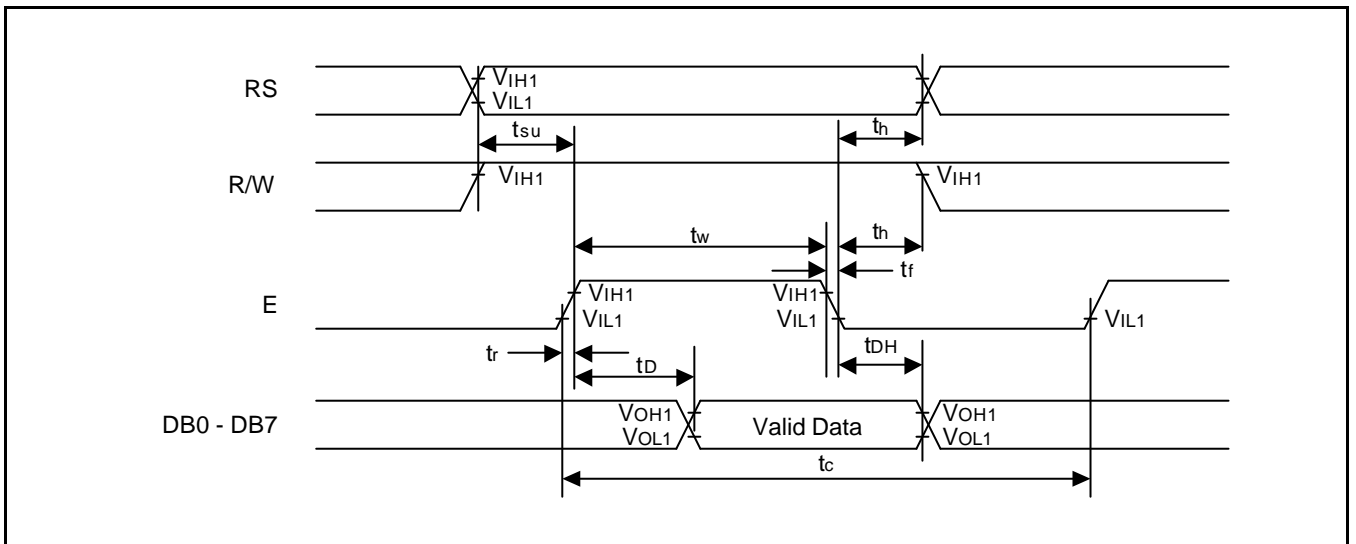

Figure 16. Read Mode

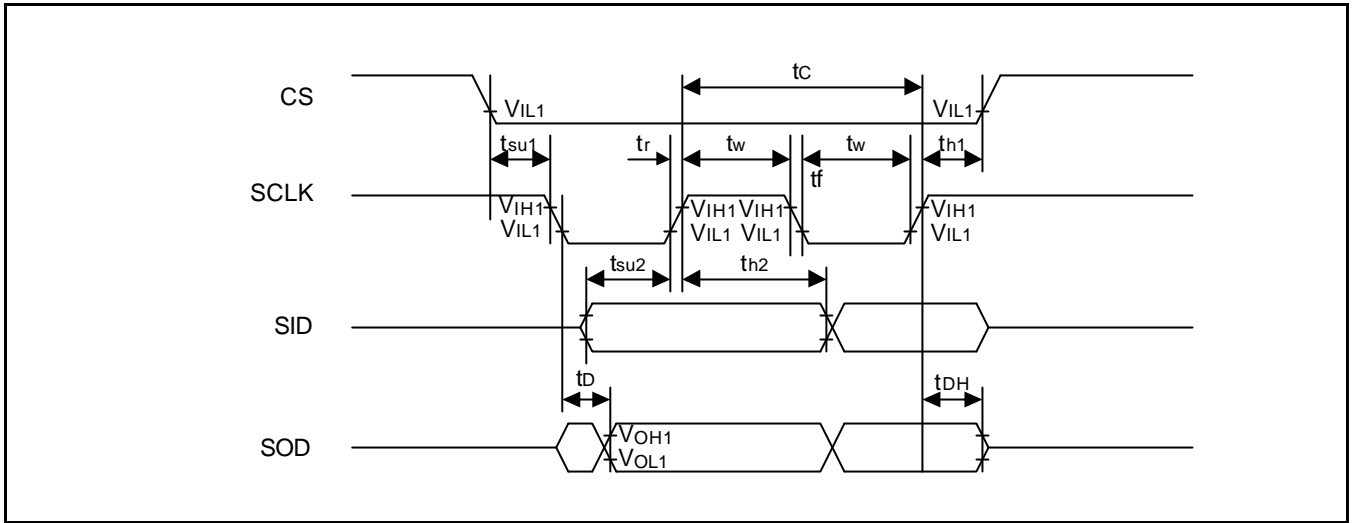

Figure 17. Serial Interface Mode

RESET TIMING

($V_{DD} = 2.7$ to $5.5V$, $T_A = -30$ to $+85^\circ C$)

Item	Symbol	Min	Typ	Max	Unit
Reset low level width (refer to Figure 18)	t_{RES}	10	-	-	ms

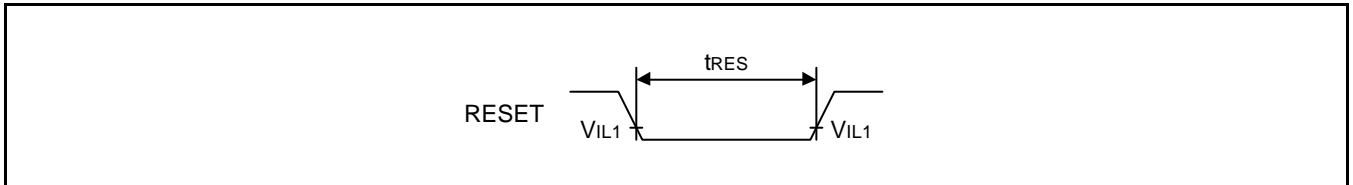

Figure 18. Reset Timing Diagram

NOTES