

SPI-Based Data Acquisition/Monitor Using the TLC2551 Serial ADC

Tom Hendrick

Advanced Analog Applications

ABSTRACT

The TLC2551 12-bit serial output analog to digital converter can easily interface to the serial peripheral interface port of many popular microcontrollers. This application report focuses on using the SPI port of the MSP430F149 and 68HC912 microcontroller in a complete data acquisition system using the TLC2551 analog to digital converter and the TLV5616 digital to analog converter.

Contents

Introduction	2
System Timing.....	3
A to D Requirements	3
D to A Requirements	3
TLC2551 Serial Interface	4
TLC2551 Timing.....	4
TLV5616 Timing.....	5
MSP430F149 Code Example	6
68HC912 Code Example.....	10

Figures

Figure 1. System Block Diagram.....	2
Figure 2. System Timing Diagram.....	3
Figure 3. TLC2551 Timing Diagram.....	4
Figure 4. TLV5616 Data Register.....	5
Figure 5. TLV5616 Timing Diagram.....	5

Tables

Table 1. I/O Pins of the TLC2551.....	4
Table 2. I/O Pins of the TLV5616.....	5

For questions regarding this or other data converter products, e-mail the Data Converter Applications Team at dataconvapps@list.ti.com. Please include the product name in the subject heading.

Introduction

The TLC2551 ADC requires a falling clock edge while the chip select pin is in the high state in order to release the output data. This requirement can be satisfied by writing to a second device on the serial bus, while holding the ADC's chip select pin high. This application report describes how to use the TLC2551 ADC in conjunction with the TLV5616 DAC, creating a complete data acquisition system.

In this application report, an I/O pin on the microprocessor is assigned to perform the duties of frame sync for the digital to analog converter. The DAC's chip select pin is permanently held low. An alternative approach would be to use the inverted output of the SS/CS pin from the microcontroller as the DAC chip select.

The output from the TLV5616 can be used as the feedback signal in a control loop or as a system monitor.

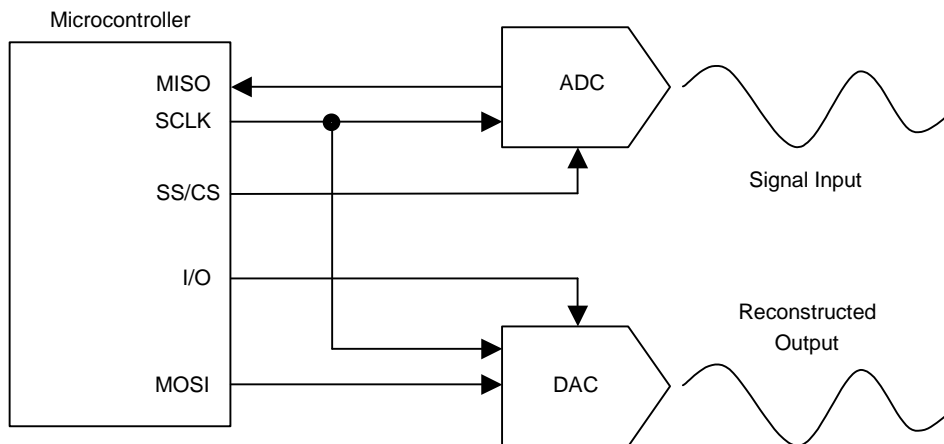

Figure 1. System Block Diagram

System Timing

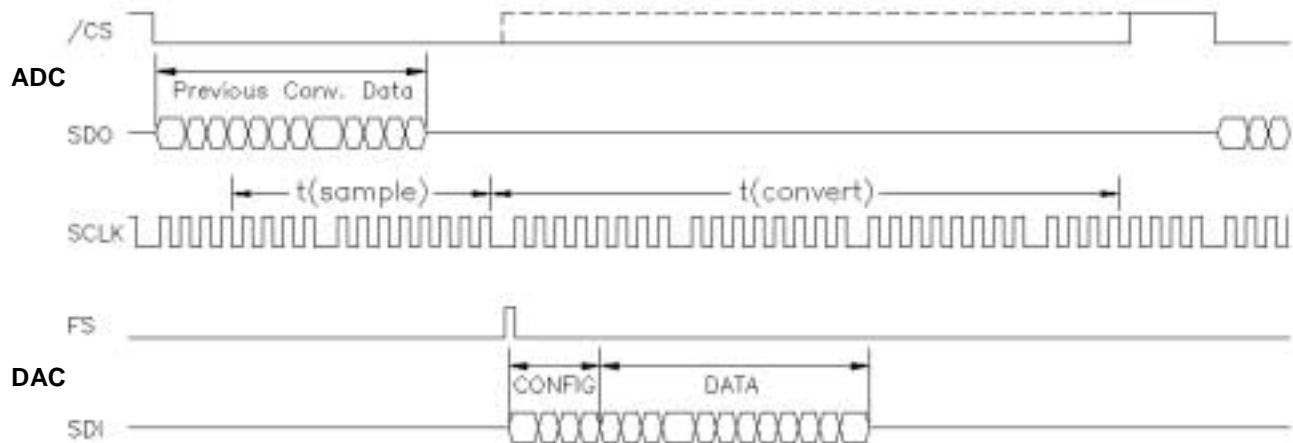

Figure 2. System Timing Diagram

A to D Requirements

The 12-bits of serial output data from the TLC2551 are presented MSB first after the falling edge of chip select. The ADC's chip select pin must be held low through two SPI transfers in order to allow the ADC to output the contents of its data register. Output data changes on the rising edge of SCLK, and is valid on the falling. The ADC also uses this time to complete the next data sampling cycle. For data to be released on the next chip select cycle, the ADC requires at least one falling SCLK edge while its chip select pin is in the high state. Asserting the micro's SS/CS pin high before the completion of conversion, satisfies this requirement. Frame sync to the ADC is held high in this application.

D to A Requirements

Output data from the ADC is stored as two 8-bit words in the microprocessor. Before the data can be transmitted to the TLV5616 it must be formatted. Since the DAC is expecting the first data nibble to contain configuration information, the data received from the ADC must be padded with leading zeros by shifting the data right by four bits. Conversion speed and power down commands can be inserted by masking the shifted data.

The DAC's chip select is held low in this application. Toggling a general-purpose I/O pin on the micro can generate frame Sync to the DAC. This alerts the DAC to an incoming serial data stream. Data is presented to the DAC MSB first, in two subsequent SPI transfers from the microcontroller. The first four bits of data contain the configuration information, while the remaining 12-bits are data from the previous ADC conversion results.

TLC2551 Serial Interface

The TLC2551 is a 12-bit serial output successive approximation analog to digital converter. The device is available in 8-pin MSOP and SOIC packages. Since there are no configuration registers in the device, it is relatively simple to use. Table 1 lists the I/O pins and their function.

Table 1. I/O Pins of the TLC2551

Pin	Description
/CS	Chip select – An active low signal. A high-to-low transition removes the SDO pin from 3-state.
V _{REF}	External reference input
GND	Ground return for internal circuitry
AIN	Analog input
SCLK	Input serial clock
V _{DD}	Positive supply voltage (5VDC)
FS	Frame sync
SDO	3-state serial output for the conversion result.

TLC2551 Timing

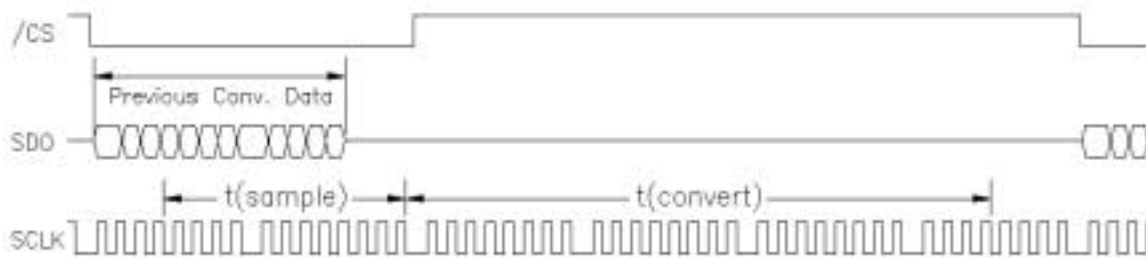

Figure 3. TLC2551 Timing Diagram

The TLC2551 requires 12 SCLK's to complete its sampling. The sampling period begins after the fourth falling SCLK edge. Chip select must be held in a low state for the entire 16 clock cycles before a valid conversion will take place. When operated with an SPI controller, the chip select signal can be removed after two 8-bit transfers from the SPI port.

The conversion cycles starts after the 16th falling SCLK edge and takes 28 clock cycles to complete. The results are presented on SDO during the next cycle.

TLV5616 Serial Interface

The TLV5616 is a 12-Bit voltage output digital-to-analog converter (DAC) with a serial interface. When the device is enabled - /CS held low – a falling edge of frame sync starts shifting data to the internal register. The input data format is a 16-bit serial string which contains four control and 12 data bits.

Table 2. I/O Pins of the TLV5616

Pin	Description
DIN	Serial input data – 16-Bit format, first 4 MSB's are control bits, followed by 12 data bits
SCLK	Serial input clock
/CS	Chip select – An active low signal used to enable and disable inputs
FS	Frame sync – This pin is used in DSP based systems to synchronize data transfers. In microcontroller systems, this pin can be used as chip select
AGND	Analog ground
REFIN	Reference analog voltage
OUT	DAC analog output voltage
V _{DD}	Analog supply voltage (2.7-5.5VDC)

The TLV5616 uses a 16-bit data format with the first four MSB's containing device programming information, followed by the 12-bits of serial data to be converted. Data bit D14 controls the conversion speed, while D13 provides a software power down. Setting D14 puts the device in fast conversion (3uS) mode. Setting D13 puts the TLV5616 in power down (10nA) mode.



Figure 4. TLV5616 Data Register

TLV5616 Timing

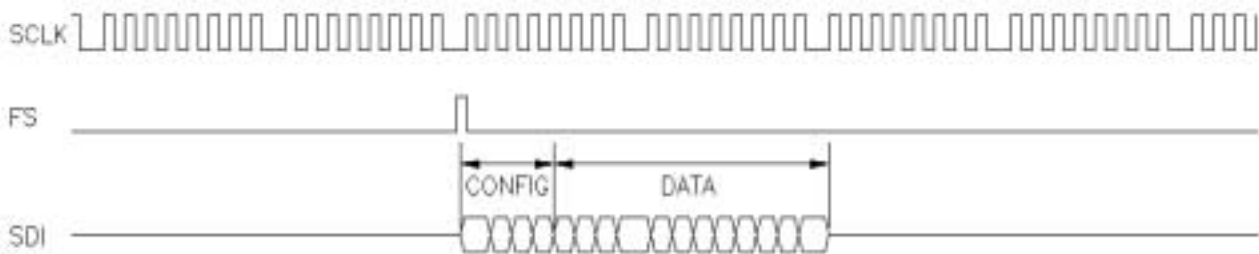

Figure 5. TLV5616 Timing Diagram

Note: The DAC's chip select pin is held low in this application and therefore is not shown on the timing diagram.

```

ADC_CS      equ    001h                ; Assign p3.1 to ADC_CS
FS          equ    010h                ; Assign p3.6 to FS (DAC and ADC)
DAC_CS      equ    020h                ; Assign p5.4 to DAC_CS

;*****
;Setup Stack
;*****
        RSEG    CSTACK
        DS      0

;*****
;Program Code
;*****
        RSEG    CODE
;*****
RESET_ISR  mov     #SFE(CSTACK),SP     ; define stackpointer
          call    #Init_Sys           ; Initialize the MSP430
          call    #Mainloop           ; Run the Main Program

Mainloop
Read_ADC   bic.b  #ADC_CS,&P3OUT
          mov.b  #DUMMY,&U0TXBUF      ; Dummy write to SPI (generates SCLK)
          call   #CLEAR
          mov.b  &U0RXBUF,R12        ; Store Upper Byte
          mov.b  #DUMMY,&U0TXBUF      ; Dummy write to SPI (generates SCLK)
          call   #CLEAR
          mov.b  &U0RXBUF,R13        ; Store Lower Byte

          mov.b  #04h, R7

CLK_LOOP   mov.b  #DUMMY,&U0TXBUF      ; Dummy write to SPI
CONV_CLK   bit.b  #01h,&IFG2          ; TXBUF ready?
          jnc   CONV_CLK             ; 1 = ready
          bic.b  #01h,&IFG2
          dec   R7
          cmp   #00h, R7
          jnz   CLK_LOOP
          bic.b  #ADC_CS,&P3OUT

;          jmp  Mainloop              ; Repeat
; Remove remark from above line to skip transmit back to DAC
    
```

```

Write_DAC  bis.b #001h,&P3OUT          ; Turn on LED of F149 Board
          swpb      R12                ; Swap Bytes
          add.w R12, R13
          and.w #0xFFFF, R12         ; Strip trailing bits
          rrc.w   R12                ; Shift data 4 places
          rrc.w   R12                ;   to conform to
          rrc.w   R12                ; DAC input format
          rrc.w   R12                ; Data is shifted!
          and.w #0xFFFF, R12         ; Strip any carries
          add.w #0x4000, R12         ; Set DAC Fast Mode, 0x4000

          bic.b #FS,&P3OUT           ; Clear FS to DAC
          bic.b #DAC_CS,&P3OUT       ; Enable /CS to DAC
          bis.b #FS,&P3OUT           ; Toggle FS to prepare DAC
          bic.b #FS,&P3OUT           ; to receive DATA
          swpb R12                   ; Align MSB First
          mov.b R12,&U0TXBUF         ; Transmit upper Data Byte to DAC
          call #CLEAR
          swpb R12                   ; Prepare Lower Byte
          mov.b R12,&U0TXBUF         ; Transmit lower Data Byte to DAC
          call #CLEAR
          bis.b #DAC_CS,&P3OUT       ; Disable /CS to DAC
          bis.b #FS,&P3OUT           ; Set Frame Sync
          bic.b #001h,&P3OUT         ; Turn off LED of F149 Board
          jmp Mainloop              ; Repeat

;*****
; Clear TX Flag
;*****
CLEAR
    bit.b # UTXIFG0,&IFG1; TXBUF ready?
    jnc CLEAR                ; 1 = ready
    bic.b # UTXIFG0,&IFG1
    ret

;*****
Init_Sys; Modules and Controls Registers set-up subroutine
;*****
StopWDT  mov      #WDTPW+WDTHOLD,&WDTCTL ; Stop Watchdog Timer

```

```

SetupClock
    bic.b #XTOFF, &BCSCTL1
    bis.b #SELM2+SELS, &BCSCTL2
HF_WAIT ; 8MHz Crystal used - wait for stabilization
    bic.b #OFIFG, &IFG1
    bit.b #OFIFG, &IFG1
    jnz HF_WAIT
    bic.b #OFIFG, &IFG1 ; Clear Oscillator fault flag
    bit.b #OFIFG, &IFG1 ; Test for clear
    bis.b #001h,&P1DIR ; P1 pin 1 set to output (toggle's LED)

Setup_SPI0_Port
    bis.b #00Eh,&P3SEL ; P3.1,2,3 SPI option select
    bis.b #ADC_CS+FS+DAC_CS,&P3DIR ; /CS, FS = P3 output direction
    bis.b #ADC_CS+FS+DAC_CS,&P3OUT ; P3.5,6,7 CS & FS set

SetupInterrupt
    bic.b #02h, &P1IFG ; Clear interrupt flags

SetupSPI0
    bis.b #040h,&ME1 ; Enable SPI TX/RX
    mov.b #CHAR+SYNC+MM,&U0CTL ; 8-bit SPI Master
    bis.b #SSEL0+SSEL1+STC,&U0TCTL
    mov.b #02h,&U0BR0 ; Set SPI Baud Rate
    mov.b #00h,&U0BR1 ; This give 4MHz SCLK w/ 8MHz Crystal
    mov.b #00h,&U0MCTL
    ret

;*****
COMMON INTVEC ; MSP430x11x1/MSP430F14x Interrupt vectors
;*****
ORG RESET_VECTOR
RESET_VEC DW RESET_ISR ; POR, ext. Reset, Watchdog
END
    
```

68HC912 Code Example

```

;*****
;      Motorola 68HC912 Demo - SPI Communication with TLC2551 and TLV5616
;      Using the M68EVB912B32 Demo Bd. with DeBug12
;      Assembled with ASM12.EXE
;
;      TLC2551          68HC912          TLV5616
;
;      -----
;      |          CS|<---|PS.7    PS.3|---->|FS          |
;  ~~~~>|IN+    SCLK|<---|    PS.6    |---->|SCLK    OUT+|~~~~>
;      |          SDO|<--->|PS.4    PS.5|---->|SDI          |
;      |          |    |          |    |          |          |
;
;
;      T. Hendrick
;      Analog Applications Group
;      Texas Instruments, Inc
;      August 2000
;*****
;* -----
;* Equates and Variables
;* -----
SP0CR1:  equ $D0          ;SPI 0 Control Register 1
SP0CR2:  equ $D1          ;SPI 0 Control Register 2
SP0BR:   equ $D2          ;SPI 0 Baud Rate Register
SP0SR:   equ $D3          ;SPI 0 Status Register
SP0DR:   equ $D5          ;SPI 0 Data Register
PORTS:   equ $D6          ;Port S Data Register
DDRS:    equ $D7          ;Port S Data Direction Register
; User Variables
Upper_Byte:  EQU    $0B00
Lower_Byte:  EQU    $0B01
;* -----
;*          MAIN PROGRAM
;* -----
      ORG    $0800          ; User code data area,
                          ; start main program at $0800
DATA FCB    00,01          ; Set up 16 bit DATA
MAIN:

```

```

        BSR      INIT                ; Subroutine to initialize SPI registers
        BSR      SAMPLE              ; Subroutine to start transmission

;* -----
;*           Initialization Subroutine
;* -----
INIT:
        BSET    DDRS,  #11101100    ; Configure PORT S input/ouput:
                                        ; SS/CS, SCK, MOSI, MISO, PS3, PS2, TXD, RXD

        BSET    SP0BR,  #00000000    ; Set Baud Rate
        BSET    SP0CR1, #01010100    ; Configure SPI(SP0CR1):
                                        ; SPIE, SPE, SWOM, MSTR, CPOL, CPHA, SSOE, LSBF

        BSET    SP0CR2, #00000000    ; Configure SPI(SP0CR2):
                                        ; -,-,-,-,-,SSWAI, SPCO

        MOVB   #$00,  UPPER_BYTE
        MOVB   #$00,  LOWER_BYTE
        RTS

;* -----
;*           Sample / Convert
;* -----
SAMPLE:
        MOVB   #$00,  PORTS          ; Sets ADC CS Lo
        MOVB   #$00,  SP0DR          ; Write zero value to data register
                                        ; to generate SCLK for ADC

        BSR    FLAG                  ; Clear SPIF
        LDAA   SP0DR                 ; Load first ADC Sample
        MOVB   #$00,  SP0DR          ; Write zero value to data register
                                        ; to generate SCLK for ADC

        BSR    FLAG                  ; Clear SPIF
        LDAB   SP0DR                 ; Load second ADC Sample
        STD    DATA                  ; Store ACCA and ACCB in Data

;* -----
;*           Data Shifting Subroutine
;* -----
        LDX   #$0004                  ; Shift data four bits to
                                        ; bypass DAC config registers
    
```

```

LOOP:
    LSRD                ; R Shift ACCD
    DBNE X,LOOP        ; Loop 4 times
    STAA UPPER_BYTE    ; Store shifted data
    STAB LOWER_BYTE    ; Store shifted data

;* -----
;* Transmit Subroutine
;* -----

    MOVB #$80, PORTS    ; ADC CS Hi
    BSET PORTS, #%00001000 ; Set FS to DAC(PS3) Hi
    BCLR PORTS, #%00001000 ; Set FS to DAC(PS3) Lo
    MOVB UPPER_BYTE, SP0DR ; Load Data Register with Upper Byte
    BSR FLAG
    MOVB LOWER_BYTE, SP0DR ; Load Data Register with Upper Byte
    BSR FLAG
    MOVB #$00, SP0DR    ; Load Data Register with Zero
    BSR FLAG
    MOVB #$00, SP0DR    ; Load Data Register with Zero
    BSR FLAG
    BRA SAMPLE         ; Go back and do it again

;* -----
;* Clear SPIF
;* -----

FLAG:
    BRCLR     SPOSR, #$80, FLAG    ; Wait for flag.
    RTS

```

References

1. *Multi Converter EVM Users Guide* (SPRU131)
2. *MSP430x1xx Family User's Guide* (SLAU049)
3. *Motorola Semiconductor Technical Data – MC68HC912B32* (MC68HC912B32TS/D)
4. *TLV5616 data sheet* (SLAS152)
5. *TLC2551 data sheet* (SLAS276)

IMPORTANT NOTICE

Texas Instruments Incorporated and its subsidiaries (TI) reserve the right to make corrections, modifications, enhancements, improvements, and other changes to its products and services at any time and to discontinue any product or service without notice. Customers should obtain the latest relevant information before placing orders and should verify that such information is current and complete. All products are sold subject to TI's terms and conditions of sale supplied at the time of order acknowledgment.

TI warrants performance of its hardware products to the specifications applicable at the time of sale in accordance with TI's standard warranty. Testing and other quality control techniques are used to the extent TI deems necessary to support this warranty. Except where mandated by government requirements, testing of all parameters of each product is not necessarily performed.

TI assumes no liability for applications assistance or customer product design. Customers are responsible for their products and applications using TI components. To minimize the risks associated with customer products and applications, customers should provide adequate design and operating safeguards.

TI does not warrant or represent that any license, either express or implied, is granted under any TI patent right, copyright, mask work right, or other TI intellectual property right relating to any combination, machine, or process in which TI products or services are used. Information published by TI regarding third-party products or services does not constitute a license from TI to use such products or services or a warranty or endorsement thereof. Use of such information may require a license from a third party under the patents or other intellectual property of the third party, or a license from TI under the patents or other intellectual property of TI.

Reproduction of information in TI data books or data sheets is permissible only if reproduction is without alteration and is accompanied by all associated warranties, conditions, limitations, and notices. Reproduction of this information with alteration is an unfair and deceptive business practice. TI is not responsible or liable for such altered documentation.

Resale of TI products or services with statements different from or beyond the parameters stated by TI for that product or service voids all express and any implied warranties for the associated TI product or service and is an unfair and deceptive business practice. TI is not responsible or liable for any such statements.

Mailing Address:

Texas Instruments
Post Office Box 655303
Dallas, Texas 75265