

# **Using the TPS3619 with MSP430 Microcontrollers Can Reduce System Power Consumption With Charge Pumps**

Dennis Hudgins

Power Management Products/Portable Power DC-DC Apps

## **ABSTRACT**

The MSP430 series of microcontrollers are ideal in applications where battery life is critical. These microcontrollers require only 0.1 $\mu$ A of current in low-power RAM retention mode; In this mode the microcontroller must have power to retain volatile memory. In some systems with charge pumps, the TPS3619 can be used to shut down the charge pump, saving system power consumption.

For many portable-power applications, the power consumed during shutdown mode is more critical than power consumed while active. This is particularly true for portable monitoring equipment such as digital thermometers, blood glucose meters, or battery-powered blood pressure monitors. In these applications, measurements are made, calculations are performed, and the result is displayed on a liquid crystal display (LCD) or stored in memory for future retrieval. To conserve battery life, the circuit usually enters a low power sleep/standby mode between measurements. Because such a device may be active only a small percentage of the total time, the current drain on the battery during sleep mode significantly affects battery life. Due to the volatile nature of the internal RAM of the microcontroller, a voltage source must be applied to retain data stored in RAM. In some cases, with systems that use charge pumps, a battery backup supervisor such as the TPS3619 allows the power supply to be disabled. The TPS3619 allows the battery to supply power directly to the MSP430 when the power supply is disabled saving system power consumption when the MSP430 is in a low-power mode. Figure 1 shows a typical application for using the TPS3619 and a charge pump with the MSP430 series microcontrollers.

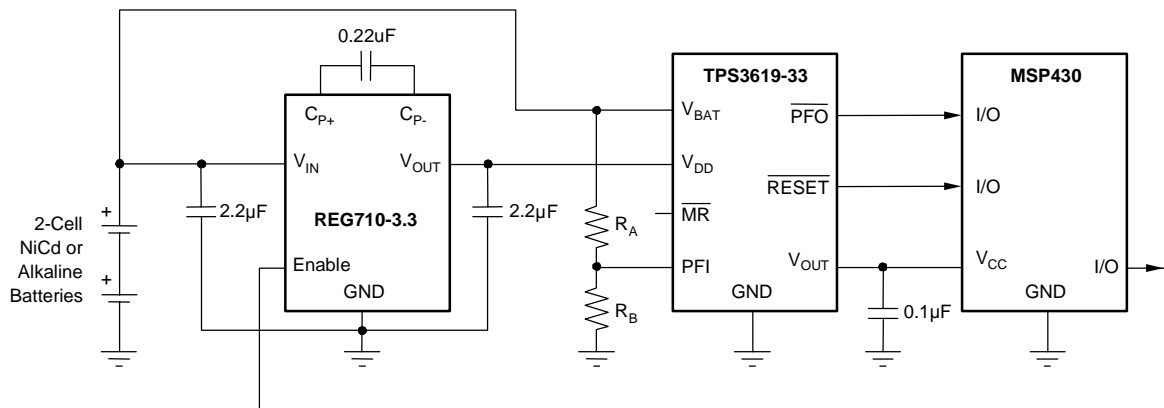

**Figure 1. Two-Cell to 3.3V Power Solution for MSP430 with SVS for RAM Retention**

The circuit in Figure 1 uses the REG710 charge pump to perform the 3.3V power conversion from two-cell alkaline/NiCad batteries. If desired, any other two-cell boost converter with an enable feature can be used.

When the MSP430 microcontroller has finished processing and storing data, the device can disable the REG710. When the REG710 is disabled, the output voltage decreases until the voltage falls below the internal trip voltage,  $V_{IT}$ . At this point, the backup supervisor switches  $V_{OUT}$  from output of the REG710 to the  $V_{BAT}$  input. At the same time, the Reset pin goes low. This pin can be used to monitor when the SVS enters battery-backup mode. Using the reset signal from the TPS3619 to reset the microcontroller is not necessary because the MSP430 is powered directly from the battery. Doing so can cause the microcontroller to latch in the reset state. If the reset function is required, the TPS3606 can be used in place of the TPS3619.

In addition to providing a battery backup function, the TPS3619 can provide a low-battery detection function through the PFI pin. The PFI input of the TPS3619 connects to an internal comparator that has a 1.15V threshold. When the voltage on the PFI pin falls below 1.15V, the voltage at  $\overline{PFO}$  goes low. Resistors  $R_A$  and  $R_B$  can be used to set a user-defined low-battery threshold and must be used for the MSP430 because the minimum operating voltage for the MSP430 is 1.8V. This can be used to send a low battery indicator to the user or to trigger the microcontroller to enter a low-power mode of operation. Since the input current of the PFI pin can cause an error in the sensed voltage, the parallel combination of  $R_A$  and  $R_B$  should be below  $1M\Omega$ .

The low-battery detection feature is optional to the user and consideration should be given to the amount of constant-current draw required by resistors  $R_A$  and  $R_B$ . Resistors  $R_A$  and  $R_B$  require approximately  $2\mu A$  ( $2V/1M\Omega$ ) of constant current. In many cases, the MSP430 provides a low-battery detection feature on-chip that does not require constant current and provides a lower system-current option.

By using the TPS3619, the amount of current saved in low-power mode is approximately  $65\mu A$ . When the TPS3619 is in battery-backup mode, the current drawn from the battery is decreased to a maximum of only  $0.5\mu A$ . While active, the supply current required by the TPS3619-33 is typically only  $17\mu A$ .

## IMPORTANT NOTICE

Texas Instruments Incorporated and its subsidiaries (TI) reserve the right to make corrections, modifications, enhancements, improvements, and other changes to its products and services at any time and to discontinue any product or service without notice. Customers should obtain the latest relevant information before placing orders and should verify that such information is current and complete. All products are sold subject to TI's terms and conditions of sale supplied at the time of order acknowledgment.

TI warrants performance of its hardware products to the specifications applicable at the time of sale in accordance with TI's standard warranty. Testing and other quality control techniques are used to the extent TI deems necessary to support this warranty. Except where mandated by government requirements, testing of all parameters of each product is not necessarily performed.

TI assumes no liability for applications assistance or customer product design. Customers are responsible for their products and applications using TI components. To minimize the risks associated with customer products and applications, customers should provide adequate design and operating safeguards.

TI does not warrant or represent that any license, either express or implied, is granted under any TI patent right, copyright, mask work right, or other TI intellectual property right relating to any combination, machine, or process in which TI products or services are used. Information published by TI regarding third-party products or services does not constitute a license from TI to use such products or services or a warranty or endorsement thereof. Use of such information may require a license from a third party under the patents or other intellectual property of the third party, or a license from TI under the patents or other intellectual property of TI.

Reproduction of information in TI data books or data sheets is permissible only if reproduction is without alteration and is accompanied by all associated warranties, conditions, limitations, and notices. Reproduction of this information with alteration is an unfair and deceptive business practice. TI is not responsible or liable for such altered documentation.

Resale of TI products or services with statements different from or beyond the parameters stated by TI for that product or service voids all express and any implied warranties for the associated TI product or service and is an unfair and deceptive business practice. TI is not responsible or liable for any such statements.

Following are URLs where you can obtain information on other Texas Instruments products & application solutions:

<b>Products</b>		<b>Applications</b>	
Amplifiers	<a href="http://amplifier.ti.com">amplifier.ti.com</a>	Audio	<a href="http://www.ti.com/audio">www.ti.com/audio</a>
Data Converters	<a href="http://dataconverter.ti.com">dataconverter.ti.com</a>	Automotive	<a href="http://www.ti.com/automotive">www.ti.com/automotive</a>
DSP	<a href="http://dsp.ti.com">dsp.ti.com</a>	Broadband	<a href="http://www.ti.com/broadband">www.ti.com/broadband</a>
Interface	<a href="http://interface.ti.com">interface.ti.com</a>	Digital Control	<a href="http://www.ti.com/digitalcontrol">www.ti.com/digitalcontrol</a>
Logic	<a href="http://logic.ti.com">logic.ti.com</a>	Military	<a href="http://www.ti.com/military">www.ti.com/military</a>
Power Mgmt	<a href="http://power.ti.com">power.ti.com</a>	Optical Networking	<a href="http://www.ti.com/opticalnetwork">www.ti.com/opticalnetwork</a>
Microcontrollers	<a href="http://microcontroller.ti.com">microcontroller.ti.com</a>	Security	<a href="http://www.ti.com/security">www.ti.com/security</a>
		Telephony	<a href="http://www.ti.com/telephony">www.ti.com/telephony</a>
		Video & Imaging	<a href="http://www.ti.com/video">www.ti.com/video</a>
		Wireless	<a href="http://www.ti.com/wireless">www.ti.com/wireless</a>

Mailing Address: Texas Instruments  
Post Office Box 655303 Dallas, Texas 75265