

Interfacing the MSOP8 EVM to TMS320C5x Processors

Tom Hendrick

Data Acquisition Products

ABSTRACT

This application note presents a method for interfacing the modular MSOP8 evaluation module (EVM), an EVM for single-channel, low-power, 8- to 16-bit serial analog-to-digital converters to the TMS320C5x series DSKs using a 5-6K interface board. The software developed provides compile options to choose the proper data formatting for the ADS7816, ADS7817, ADS7818, ADS7822, ADS7826, ADS7827, ADS7829, ADS7835, ADS7835, ADS8320, ADS8321, ADS8324, and ADS8325. To reduce development time, the source code for this application note can be found on the Texas Instruments Web site at <http://www.ti.com>.

Contents

1	Introduction	2
2	Hardware	2
	2.1 TMS320C5x DSKs	2
3	MSOP8 EVM	2
	3.1 Hardware Interface	2
4	Software Interface	3
	4.1 Board Support Libraries	3
	4.2 McBSP Setting	3
	4.3 Software Flow	4
	4.4 Software Compile Options	5
5	References	6

Figures

Figure 1.	Hardware Interface Block Diagram	3
Figure 2.	Software Flow Chart	5

1 Introduction

The design of the modular MSOP8 evaluation module (EVM) allows any one of 13 different high-speed, micropower analog-to-digital converters to be placed on a single PCB fabrication. This family of converters is able to gluelessly interface to the TMS320C5x digital signal processors when the EVM is used with the 5-6K interface board. For the development of this application note, the TMS320C5402, TMS320C5416, and TMS320C5510 DSP starter kits (DSK) were used along with the modular MSOP8 EVM and the 5-6K interface board. Two MSOP8 EVMs can be run concurrently because the provided software example initializes both serial ports available through the peripheral connector of the associated DSK.

2 Hardware

The combination of the TMS320C5x DSK and the 5-6K interface board is a convenient way of experimenting with the TMS320C5x series DSPs and the variety of data converters available on the MSOP8 EVM. The MSOP8 EVM plugs onto the 5-6K interface board, which then plugs directly into the DSK through mating connectors compatible with the TMS320 cross-platform daughtercard interface (see Reference 2) connectors found on the DSK platform.

2.1 TMS320C5x DSKs

The TMS320C5x DSP DSKs not only provide an introduction to C5000 DSP platform technology, but also are powerful enough to use for fast development of networking, communications, imaging, and other applications like data acquisition. See TI's Web site (www.ti.com) for more information on the TMS320C5x series DSKs.

3 MSOP8 EVM

The modular MSOP8 EVM provides a platform to demonstrate the functionality of the ADS7816, ADS7817, ADS7818, ADS7822, ADS7826, ADS7827, ADS7829, ADS7835, ADS7835, ADS8320, ADS8321, ADS8324, and ADS8325 analog-to-digital converters. The EVM interfaces with various Texas Instruments DSPs and microcontrollers, while allowing easy access to all analog and digital signals for customized end-user applications. For more information on the EVM, see the user's guide (Reference 4) available on the TI Web site.

3.1 Hardware Interface

The hardware interface is seamless between the C5x DSKs and the MSOP8 EVM. The 5-6K interface board provides direct access to the C5402, C5416, and C5510 DSK McBSP ports zero and one.

Figure 1 shows the hardware connections via the 5-6K interface board. The DCLOCK, /CS, and SDO pins from the data converter are connected to CLKX, FSX, and DR pins of the McBSPx, respectively. The /CS (SHDN) pin also can be controlled through GPIO functions via jumper JMP2 found on the EVM. For the purpose of this application note, it is assumed JMP2 has a shunt jumper loaded at position 1-2 (use DSP FSx as the controlling signal).

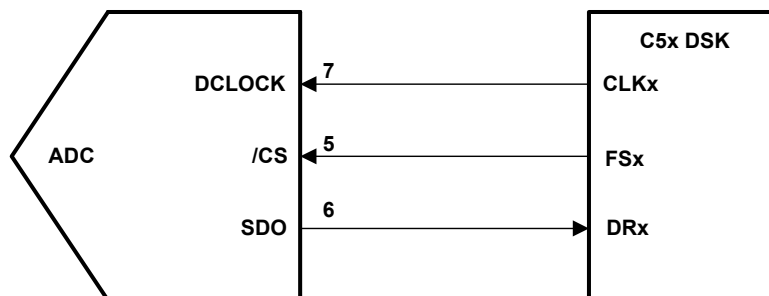

Figure 1. Hardware Interface Block Diagram

4 Software Interface

The code archive associated with this application note (*SLAA201.ZIP*) contains three folders and three separate Code Composer Studio™ projects. The three project folders identify the associated processor. Extract the archive to the “myprojects” folder of your CCS installation and locate the MSOP8_xxxx folder for your installed DSK (replace xxx with 5402, 5416, or 5510).

All of the software was written and compiled using Code Composer Studio version 2.20. The most involved portion of writing the code for this simple interface is programming the multichannel buffered serial port (McBSP). If using an earlier version of Code Composer Studio, you must re-create the DSP configuration file (MSOP8_xxxx.cbd) associated with the project.

4.1 Board Support Libraries

The C5510 DSK requires board support library files (*.bsl) in order to assign the McBSP signals to the 5-6K interface board. The library files must be included in the projects in order for the code examples to work properly. Copies of the appropriate BSL files are located in the software example archive.

4.2 McBSP Setting

The graphic user interfaces (GUI) of the configuration tool (i.e., CDB file), DSP/BIOS, and CSL have made it easy to write programs and set up the McBSP. To see how to set up the McBSP registers, double click on the .cdb file (in the code example provided, choose the MSOP8_5402.CDB from the DSP/BIOS Config tab) from within the project window. Browse through the CDB tree, and find the McBSP configuration manager under CSL. Right click on mcbSPCfg0, and select *properties*. This is where the McBSP registers are found as tabs, with individual bit field settings found as pulldown options. Once all options have been selected, click OK, then choose *Rebuild All* from the *Project* pulldown menu. Register options can be confirmed by opening the file MSOP8_5402cfg_c.c under the “Generated Files” branch in the project manager window. The GUI-generated McBSP configurations for C5402 DSK project example used in this application follow.

```

MCBSP_Config mcbSPCfg0 = {
    0x0000,      /* Serial Port Control Register 1 */
    0x0200,      /* Serial Port Control Register 2 */
    0x0080,      /* Receive Control Register 1 */
    0x0001,      /* Receive Control Register 2 */
    0x0040,      /* Transmit Control Register 1 */
    0x0000,      /* Transmit Control Register 2 */
    0x0031,      /* Sample Rate Generator Register 1 */
    0x3018,      /* Sample Rate Generator Register 2 */
    0x0000,      /* Multichannel Control Register 1 */
    0x0000,      /* Multichannel Control Register 2 */
    0x0a00,      /* Pin Control Register */
    0x0000,      /* Receive Channel Enable Register Partition A */
    0x0000,      /* Receive Channel Enable Register Partition B */
    0x0000,      /* Transmit Channel Enable Register Partition A */
    0x0000,      /* Transmit Channel Enable Register Partition B */
};

```

For the C5402 DSK, the McBSPs are programmed in nonstop clock mode (or DSP mode). The frame sync and serial clock receive signals are configured as output pins. The receiver is set for 25-bit transfers with 1-bit data delay. The frame sync (FSx) is generated by the sample rate generator and is used to strobe the /CS (SHDN) signal of the data converter by J2 pin 7 via JMP2 on the EVM. This provides 24 cycles of the serial clock to the data converter, with 1 cycle under /CS high.

In the C5402 DSK sample code, the MSOP8 board is sampled at an 80-kHz rate, with a serial clock of 2 MHz. The C5402 DSK clocks the DSP at 100 MHz. The 2-MHz clock on CLKX was achieved by setting the CLKGDV bit field in the sample rate generator register to 50. The formula for calculating the serial clock is given in Equation 1.

$$DCLOCK = (CPUCLK) / (CLKDIV) \quad (1)$$

Using Equation 1, each clock cycle is approximately 500 ns, triggering a frame-sync pulse every 25 serial clock cycles, which gives a sample rate of 80 kHz. The frame period (FPER) field, in the sample rate generator register, is where the 25-cycle period is set.

4.3 Software Flow

The software presented in this application report reads 1024 samples at 80 kHz continuously. As selected in the configuration tool, all the register and peripheral programming is done during initialization. DSP/BIOS pre-initializes all the McBSP registers and other DSP registers before arriving in the main function. As a result, the main function simply enables the interrupt service routine and the McBSPs. At this point, the DSP/BIOS and McBSP receive ISRs do all the work. When a receive interrupt occurs, the interrupting port is read, and the data formatting function is called. Formatted data is stored in array Buffer0 or Buffer1 depending on which ISR was called. When the buffer is full, the index is reset, the receive buffer is flushed, and the process starts all over again.

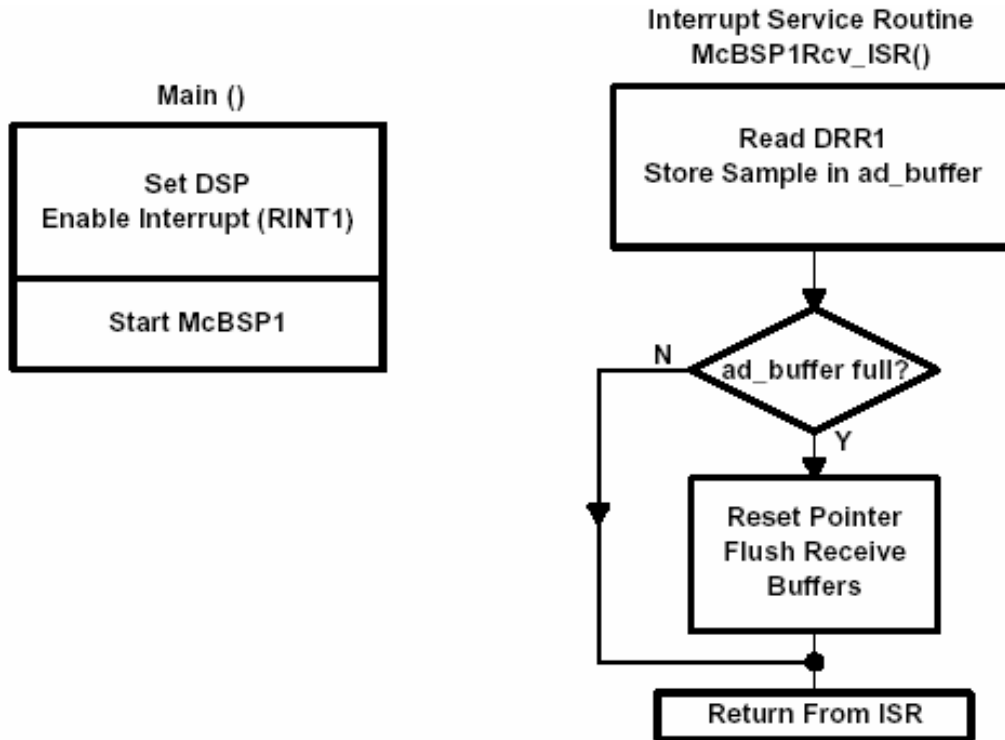

Figure 2. Software Flow Chart

The software associated with this application note allows the user to place an EVM on either McBSP available through the daughtercard interface of the DSK. The software flow shown in Figure 2 is typical of either McBSP.

4.4 Software Compile Options

As mentioned previously, the Code Composer Studio projects associated with this application note provide conditional compile statements which allow the proper data formatting function to be called. The function called is based on the resolution of the converter being tested.

```

/***** IMPORTANT!!! Please Follow these notes!!! *****/
// Change the following entries according to the group the board under test falls in.
// Only 1 entry can be set to "1", the other three must be set to "0" (zero).
#define ADS7826      (0)    // 10-Bit, 4th rising, CKPL = 0
#define ADS7827      (0)    // 8-Bit, 4th rising, CKPL = 0
#define ADS7816_17_22_29 (0) // 12-Bit, 5th rising, CKPL = 0
#define ADS7818_34_35 (0)    // 12-Bit, 4th rising, CKPL = 0
#define ADS8320_21_25 (1)    // 16-Bit, 7th rising, CKPL = 0
#define ADS8324      (0)    // 14-Bit, 7th rising, CKPL = 0
/*****/
  
```

The code shown in the preceding box can be found in the main.c file under the source tab in the CCS project manager window. Proper formatting of the data received from the data converter is achieved by simply setting #define statement to 1. Only one statement should be set to true; the others should remain 0 (not true).

5 References

1. *TMS320C5000 DSP/BIOS Application Programming Interface Reference Guide* (SPRU404)
2. *TMS320 Cross-Platform Daughtercard Interface Specification* Revision 1.0 (SPRA711)
3. *5-6K Interface Board EVM User's Guide* (SLAU104)
4. *Modular MSOP8 EVM User's Guide* (SLAU115)
5. *Designing Modular EVMs for Data Acquisition Products* (SLAA185)
6. Associated Product Data Sheets:

ADS7816

ADS7817

ADS7818

ADS7822

ADS7826/27/29

ADS7834

ADS7835

ADS8320

ADS8321

ADS8324

ADS8325

SBAS110

SBAS230

SBAS078

SBAS062

SLAS388

SBAS098

SBAS102

SBAS108

SBAS123

SBAS172

SBAS226

IMPORTANT NOTICE

Texas Instruments Incorporated and its subsidiaries (TI) reserve the right to make corrections, modifications, enhancements, improvements, and other changes to its products and services at any time and to discontinue any product or service without notice. Customers should obtain the latest relevant information before placing orders and should verify that such information is current and complete. All products are sold subject to TI's terms and conditions of sale supplied at the time of order acknowledgment.

TI warrants performance of its hardware products to the specifications applicable at the time of sale in accordance with TI's standard warranty. Testing and other quality control techniques are used to the extent TI deems necessary to support this warranty. Except where mandated by government requirements, testing of all parameters of each product is not necessarily performed.

TI assumes no liability for applications assistance or customer product design. Customers are responsible for their products and applications using TI components. To minimize the risks associated with customer products and applications, customers should provide adequate design and operating safeguards.

TI does not warrant or represent that any license, either express or implied, is granted under any TI patent right, copyright, mask work right, or other TI intellectual property right relating to any combination, machine, or process in which TI products or services are used. Information published by TI regarding third-party products or services does not constitute a license from TI to use such products or services or a warranty or endorsement thereof. Use of such information may require a license from a third party under the patents or other intellectual property of the third party, or a license from TI under the patents or other intellectual property of TI.

Reproduction of information in TI data books or data sheets is permissible only if reproduction is without alteration and is accompanied by all associated warranties, conditions, limitations, and notices. Reproduction of this information with alteration is an unfair and deceptive business practice. TI is not responsible or liable for such altered documentation.

Resale of TI products or services with statements different from or beyond the parameters stated by TI for that product or service voids all express and any implied warranties for the associated TI product or service and is an unfair and deceptive business practice. TI is not responsible or liable for any such statements.

Following are URLs where you can obtain information on other Texas Instruments products and application solutions:

Products		Applications	
Amplifiers	amplifier.ti.com	Audio	www.ti.com/audio
Data Converters	dataconverter.ti.com	Automotive	www.ti.com/automotive
DSP	dsp.ti.com	Broadband	www.ti.com/broadband
Interface	interface.ti.com	Digital Control	www.ti.com/digitalcontrol
Logic	logic.ti.com	Military	www.ti.com/military
Power Mgmt	power.ti.com	Optical Networking	www.ti.com/opticalnetwork
Microcontrollers	microcontroller.ti.com	Security	www.ti.com/security
		Telephony	www.ti.com/telephony
		Video & Imaging	www.ti.com/video
		Wireless	www.ti.com/wireless

Mailing Address: Texas Instruments
Post Office Box 655303 Dallas, Texas 75265