

Measuring Single-Ended 0V to 5V Signals with Differential Delta-Sigma ADCs

Michael Ashton

Data Acquisition Group

ABSTRACT

Most engineers use differential-input delta-sigma analog-to-digital converters (ADCs) to measure single-ended, 0V to 5V signals by grounding the negative input, and applying the signal to the positive input. For a certain class of delta-sigma converters, of which the Texas Instruments ADS1255/6, ADS1216/7/8, and ADS1240/1/2/3 are all examples, though, merely grounding the negative input cuts the dynamic range in half.

Fortunately, there are simple ways to avoid this reduction, and measure 0V to 5V signals with full dynamic range. This application note shows how to accomplish this measurement on TI's ADS1256 and ADS1110 specifically, but the principles are applicable to many other converters.

1 V_{REF} at Half Full-Scale: ADS1256

For the ADS1256, full-scale voltage is twice the reference voltage. Each input pin of this device has an input range of $0 - 2 \times V_{REF}$, and it measures differentially in both the positive and negative full-scale ranges.

The ADS1256 has several things in common with many industrial delta-sigma ADCs:

- The device is single-supply. Large negative voltages cannot be applied to any of the inputs.
- It has *fully* differential inputs. If the negative input is higher than the positive input, the device generates a negative output code.
- The negative range is always available.

The following expression gives the ideal output code in terms of V_{REF} , positive input V_{INP} , and negative input V_{INN} :

$$\text{code} = 2^{23} \frac{V_{INP} - V_{INN}}{2V_{REF}} \quad (1)$$

The ADS1256 generates codes in 24-bit, binary two's-complement (BTC) format. It can output any number representable in that format; that is, any integer from -8388608 to 8388607 . [Table 1](#) presents a few example input voltages and the codes to which they are converted.

Table 1. ADS1256 Sample Input Voltages and Output Codes in Decimal and Binary Two's Complement Formats

V_{INP}	V_{INN}	$V_{INP} - V_{INN}$	CODE IN DECIMAL	CODE IN BTC
0	0	0	0	0
5	0	5	8388607	7FFFFFFh
0	5	-5	-8388608	800000h

Table 1 shows that if V_{INN} is grounded, the ADS1256 will only output the codes from 0 to 8388607. Half of the code range will therefore be inaccessible.

One solution may be to connect V_{INN} to a voltage equal to half of full-scale, resulting in the data shown in Table 2.

Table 2. ADS1256 Output Codes with V_{INN} Input at Half of Full-Scale

V_{INP}	V_{INN}	$V_{INP} - V_{INN}$	CODE IN DECIMAL	CODE IN BTC
0	2.5	-2.5	-4194304	C00000h
2.5	2.5	0	0	000000h
5	2.5	2.5	4194304	400000h

Now the input range is centered on 0, but half of it is still missing. Fortunately, the ADS1256 has a programmable gain amplifier (PGA) that can be set to a gain of 2. This configuration effectively multiplies the input voltage by 2, giving the results shown in Table 3.

Table 3. ADS1256 Output Codes with V_{INN} Input at Half of Full-Scale, PGA = 2

V_{INP}	V_{INN}	$V_{INP} - V_{INN}$	CODE IN DECIMAL	CODE IN BTC
0	2.5	-2.5	-8388608	800000h
2.5	2.5	0	0	000000h
5	2.5	2.5	8388607	7FFFFFFh

This scheme depends on the availability of a voltage equal to half of full-scale. On the ADS1256, the reference voltage is half of full-scale, with gain equal to 1. Therefore, in the circuit shown in Figure 1, we connect the reference voltage to the negative input.

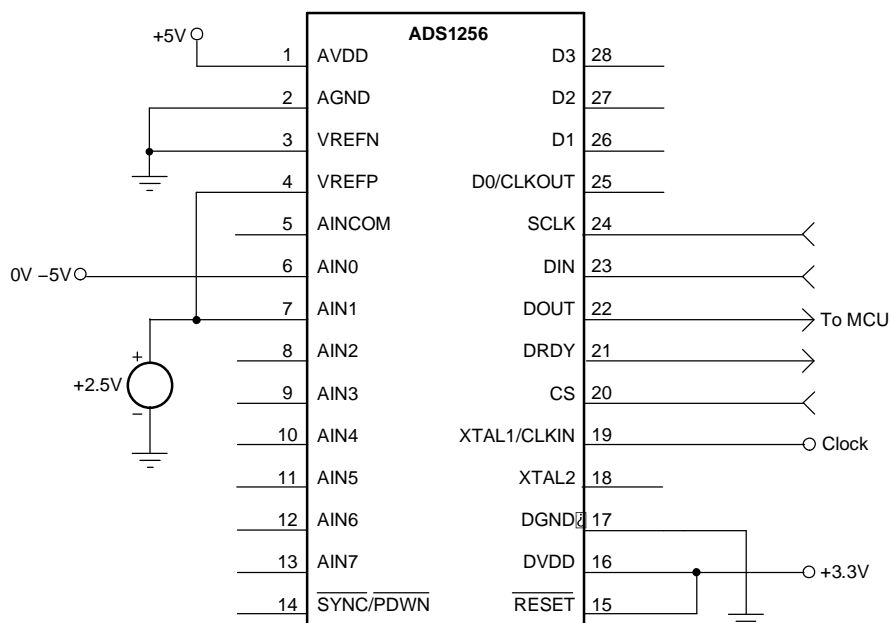

Figure 1. ADS1256 Single-Ended Measurement

When you connect V_{INN} to V_{REF} and set the PGA to 2, the transfer expression shown earlier becomes:

$$\text{code} = 2^{23} \frac{2(V_{INP} - V_{REF})}{2V_{REF}} \quad (2)$$

This expression reduces to:

$$\text{code} = 2^{23} \left(\frac{V_{INP}}{V_{REF}} - 1 \right) \quad (3)$$

This expression shows that, in this configuration, V_{REF} does not affect the zero point; it affects the full-scale voltage only, as usual.

2 Using the Results

This technique has the potentially annoying side-effect of generating a bipolar result from a unipolar input. This effect is unavoidable: the ADS1256 does not generate unsigned codes, so the number must be signed to fill the 24-bit range.

Once the number is retrieved into software, however, it may be more convenient to handle it as an unsigned number. This is easily done by adding 2^{23} , or 800000h, to the output code. Provided that the 24-bit code is stored as a 32-bit variable, there will be no overflow.

3 V_{REF} Equal to Full-Scale

Some ADCs have a full-scale range that is equal to V_{REF} . For these types of converters, do the following:

- Connect V_{REF} to V_{INN} , as shown in [Figure 1](#).
- Set V_{REF} to half of the single-ended range; for example, if you want to measure 0V to 5V, set V_{REF} to 2.5V instead of 5V.
- If the device has a PGA, set its gain to 1.

Given 24-bit word length, the transfer function is then:

$$\text{code} = 2^{23} \frac{V_{INP} - V_{REF}}{V_{REF}} \quad (4)$$

which also reduces to [Expression 3](#).

This procedure works if the ADC can tolerate a wide range of voltage references. Some delta-sigma converters are designed for a specific reference voltage, and may not perform well if the reference is set to a significantly different voltage. Be sure to examine the respective device datasheet, and perhaps experiment with the device before using this technique.

4 The ADS1110/12

The ADS1110/12 ADCs are somewhat unusual in that they can only use their internal reference, and that reference is not accessible externally. Since the maximum wordlength for these devices is 16 bits, losing half the dynamic range by grounding the negative input may be a major drawback; however, since the reference voltage is not available at all, the techniques described above cannot be directly applied to these devices.

Nevertheless, some dynamic range can be recovered. While the ADS1110 and ADS1112 cannot measure 0V to 5V directly, they can measure from 0V to 4.096V directly by using the following method:

- Supply the ADS1110/12 with 5V.
- Connect a 2.048V reference to the negative input, as shown in [Figure 2](#).
- Set the PGA to 1.

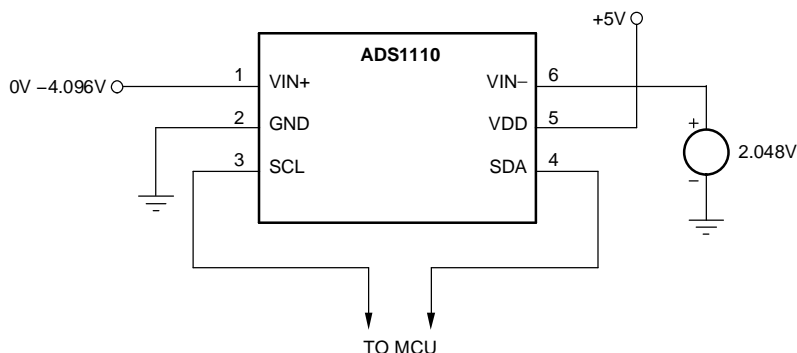

Figure 2. ADS1110 Single-Ended Measurement

If a 5V supply cannot be used, a condition that may apply if there are logic-level constraints, the input range will be further restricted to 0V to 3.3V.

Note that the ADS1110/12 on-board reference is extremely stable, and inexpensive pre-trimmed references generally will not track it very well. This characteristic means that the zero point will drift with the external reference. Any noise generated by the reference can affect the conversion.

IMPORTANT NOTICE

Texas Instruments Incorporated and its subsidiaries (TI) reserve the right to make corrections, modifications, enhancements, improvements, and other changes to its products and services at any time and to discontinue any product or service without notice. Customers should obtain the latest relevant information before placing orders and should verify that such information is current and complete. All products are sold subject to TI's terms and conditions of sale supplied at the time of order acknowledgment.

TI warrants performance of its hardware products to the specifications applicable at the time of sale in accordance with TI's standard warranty. Testing and other quality control techniques are used to the extent TI deems necessary to support this warranty. Except where mandated by government requirements, testing of all parameters of each product is not necessarily performed.

TI assumes no liability for applications assistance or customer product design. Customers are responsible for their products and applications using TI components. To minimize the risks associated with customer products and applications, customers should provide adequate design and operating safeguards.

TI does not warrant or represent that any license, either express or implied, is granted under any TI patent right, copyright, mask work right, or other TI intellectual property right relating to any combination, machine, or process in which TI products or services are used. Information published by TI regarding third-party products or services does not constitute a license from TI to use such products or services or a warranty or endorsement thereof. Use of such information may require a license from a third party under the patents or other intellectual property of the third party, or a license from TI under the patents or other intellectual property of TI.

Reproduction of information in TI data books or data sheets is permissible only if reproduction is without alteration and is accompanied by all associated warranties, conditions, limitations, and notices. Reproduction of this information with alteration is an unfair and deceptive business practice. TI is not responsible or liable for such altered documentation.

Resale of TI products or services with statements different from or beyond the parameters stated by TI for that product or service voids all express and any implied warranties for the associated TI product or service and is an unfair and deceptive business practice. TI is not responsible or liable for any such statements.

Following are URLs where you can obtain information on other Texas Instruments products and application solutions:

Products		Applications	
Amplifiers	amplifier.ti.com	Audio	www.ti.com/audio
Data Converters	dataconverter.ti.com	Automotive	www.ti.com/automotive
DSP	dsp.ti.com	Broadband	www.ti.com/broadband
Interface	interface.ti.com	Digital Control	www.ti.com/digitalcontrol
Logic	logic.ti.com	Military	www.ti.com/military
Power Mgmt	power.ti.com	Optical Networking	www.ti.com/opticalnetwork
Microcontrollers	microcontroller.ti.com	Security	www.ti.com/security
		Telephony	www.ti.com/telephony
		Video & Imaging	www.ti.com/video
		Wireless	www.ti.com/wireless

Mailing Address: Texas Instruments
Post Office Box 655303 Dallas, Texas 75265