

RC2300DK Demonstration Kit User Manual

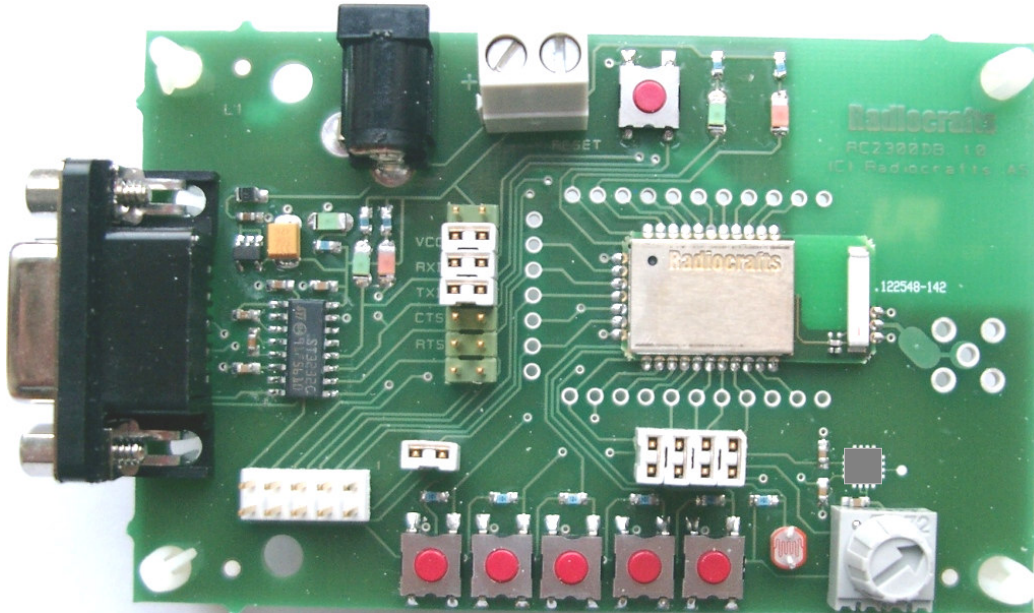

Table of contents

TABLE OF CONTENTS.....	1
INTRODUCTION	2
DEMONSTRATION BOARD.....	3
POWER SUPPLY SECTION.....	4
RS-232 INTERFACE	5
CONNECTORS	6
PUSH BUTTONS	6
LEDS	6
ACCELEROMETER.....	6
POTENTIOMETER.....	7
LIGHT SENSOR.....	7
DEBUG AND PROGRAMMING INTERFACE.....	8
I/O MAPPING	9
USING THE DEMONSTRATION KIT	10
SW IMPLEMENTATION	10
CIRCUIT DIAGRAM.....	11
BILL OF MATERIALS.....	12
PCB LAYOUT	13
TROUBLESHOOTING	15
DOCUMENT REVISION HISTORY.....	16
DISCLAIMER	16
TRADEMARKS	16
LIFE SUPPORT POLICY	16
CONTACT INFORMATION.....	16

Introduction

The RC2300 Zigbee-ready modules provide a very compact solution for a wide range of wireless network applications. The kit can be used to develop and test proprietary protocol applications as well as ZigBee-based applications.

The kit is normally shipped without any embedded firmware.

The kit can be used for development of a customer's proprietary protocol, or any Zigbee network implementation ported to the RC2300 hardware platform. In this case the user would re-flash the modules with his own application, and the program/debug interface could be used for debugging also.

The RC2300DK Demonstration Kit is designed to make it easy for the user to evaluate the module and/or develop an application very quickly. With the RC2300DK Demonstration Kit you can:

- evaluate the RF performance of the modules
- develop your own application interfacing the modules
- build a prototype of your application

This User Manual describes how to interface the Demonstration Kit and provide detailed documentation for the Demonstration Board and its onboard resources.

Your RC2300DK Demonstration Kit should contain the following items:

Kit contents	
Item	Number of articles
Demonstration Board (RC2300DB)	2
RS232 serial cable (1:1)	2
AC/DC battery eliminator 6VDC	2

Demonstration Board

The Demonstration Kit includes two Demonstration Boards. The Demonstration Boards contain the RC2300AT module and associated support circuits. The board provides an a serial port driver circuit for RS232 and the 9-pin D-Sub connector, DEBUG interface for programming and debugging, access to all digital and analogue I/O, push-buttons, LEDs, a potentiometer, a light sensor and an accelerometer as well as a voltage regulator.

Configuration jumpers and connectors make it easy to interface the RC2300 with various test equipment or the host used in an application. Not all components are needed in an actual application. Please see the datasheet for a typical application circuit.

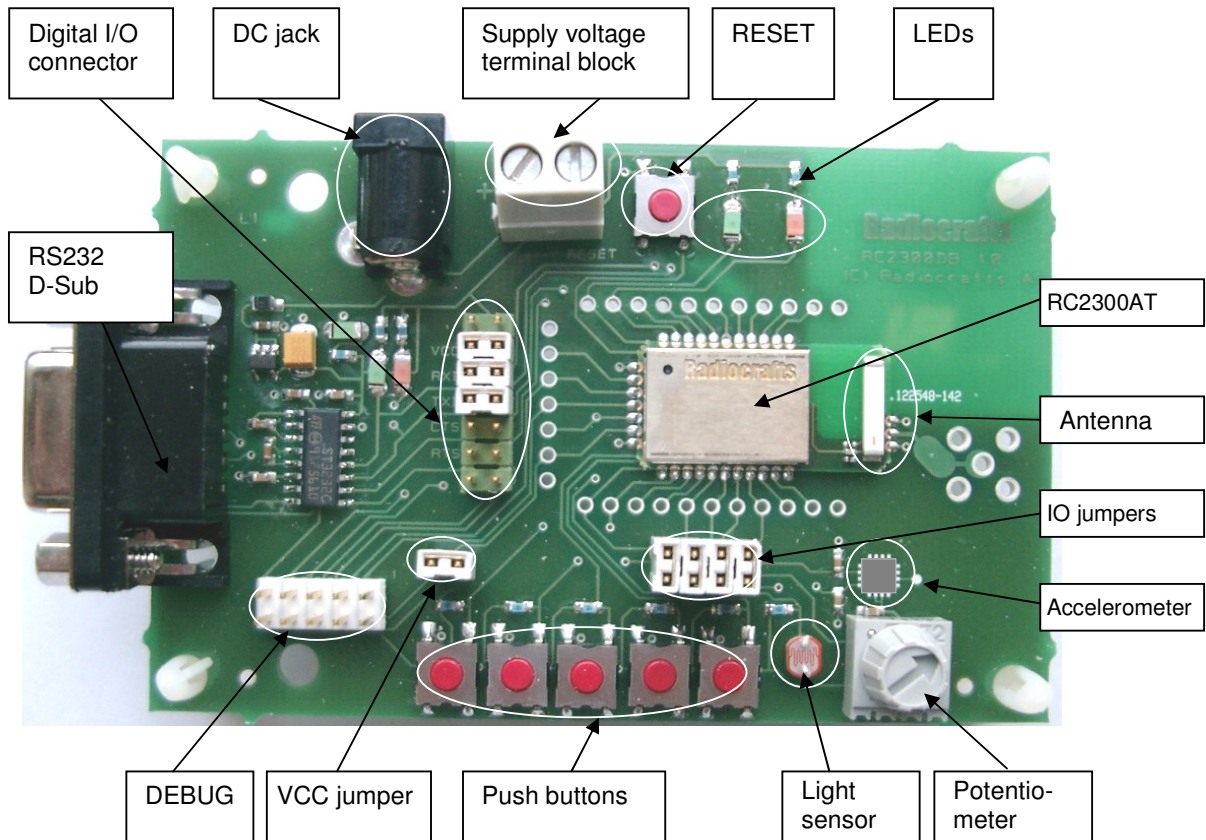

Figure 1: RC2300DB Demonstration Board

The SMA connector layout pattern is not used on this board (and is not connected to the module antenna output) as the module contains a chip antenna.

Typical range measured between two boards in line-of-sight is 110 meters when the chip antennas are oriented vertically (or parallel). Indoors a range of 10-30 can be expected, depending on the materials in walls and floors.

Power supply section

The board contains a voltage regulator. You can choose between applying a 4-10V unregulated supply voltage at the DC jack (like the battery eliminator included in the kit), or the screw terminal where a battery pack or some other supply can be connected. The on-board regulator drops the voltage to 3.0V. A green LED will light up the board is connected to a power source.

Input supply voltage range is 4 – 10 V. A series diode protects the circuit against wrong polarity.

The current supply to the module is through the jumper at P13, pin 3 and 4. An ampere meter can be connected here in order to measure the DC current drawn by the module. Remove the jumper and replace by an ampere meter in order to measure the current. The location of P13, pin 3 and 4, are shown in the figure below.

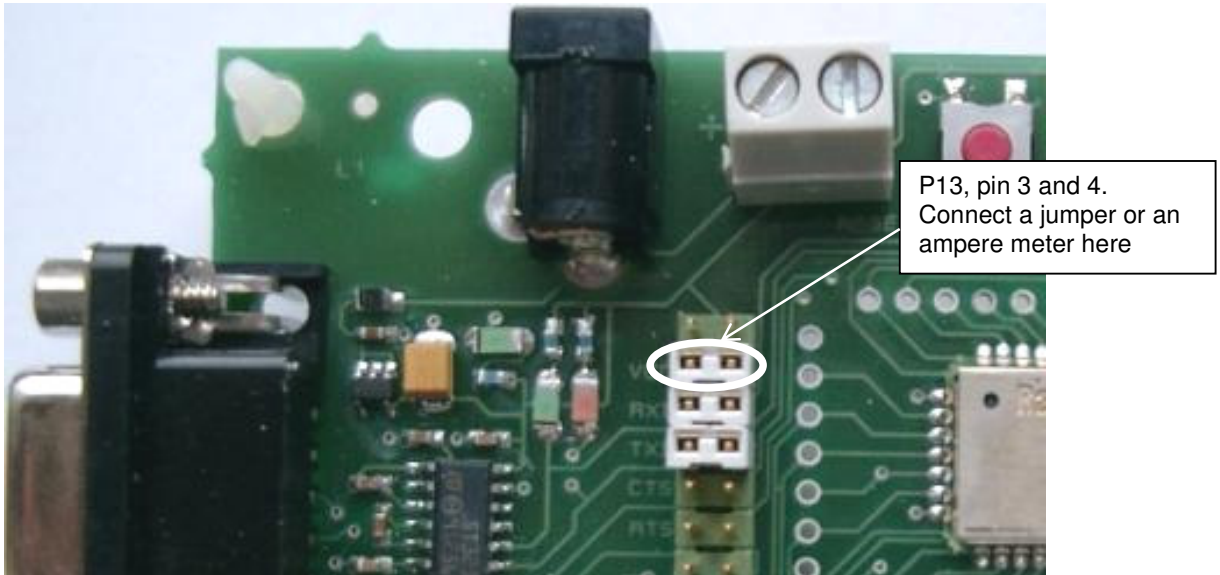

Figure 2. Module current consumption measurement

Note: To ensure proper Power-On Reset (POR) the wall socket end of the AC/DC battery eliminator should be inserted first, and then the DC-jack into the board. If the VCC power-on rise-time specification is not met, the board may need the RESET to be activated to ensure correct start-up.

RS-232 interface

The Demonstration Board provides an RS232 driver circuit. The serial port is configured as a data modem and a 1:1 cable should be used to connect the board to the PC. The RTS/CTS handshaking pair is also provided, so that hardware handshaking may be used on this port. The serial port (RXD and TXD) and handshaking signals can be HW enabled by doing the following hardware changes:

- Insert jumpers at P13 to connect RXD and TXD to the RS232 driver
- Insert jumpers at P13 to connect CTS and RTS to the RS232 driver if hardware handshake is to be used

P13 is used to set jumpers to connect the module UART interface to the RS232 PHY driver. Normally the jumpers connecting RXD and TXD are installed, and provide UART communication with a PC without handshaking. With the jumpers removed the modules RXD and TXD can easily be connected to a host using logic levels, for instance a microcontroller or external development board. The table below shows the pinout and signals at P13.

There are two LEDs indicating traffic activity on the UART. A green LED is connected to the RXD line, and a red LED at the TXD line.

Pin no.	Signal	Note
1	2	GND
3	4	VCC
5	6	RXD
7	8	TXD
9	10	CTS
11	12	RTS
13	14	GND

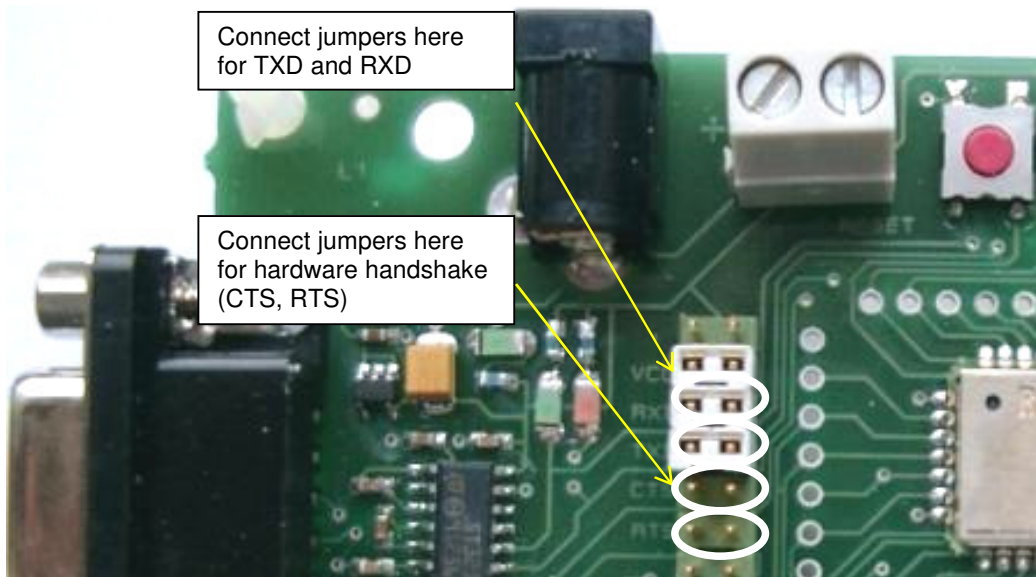

Figure 3. RS232 driver interface (Photo to be updated!)

Connectors

The Demonstration Board is furnished with many connectors for easy access to all module signals.

P5 bring out supply voltage, the DEBUG interface, a spare digital data I/O signal (Port 2) and the RESET line.

P6 brings out digital and analogue I/O (Port 0). A 2.54 mm pitch pin-row can be mounted at P6 if convenient.

P7 brings out digital I/O (Port 1) and the 32 kHz oscillator clock pins. A 2.54 mm pitch pin-row can be mounted at P7 if convenient.

P8 is the DEBUG interface (pin compatible with the TI / Chipcon SmartRF04DB DEBUG connector).

P9 is a connector for jumpers to connect/disconnect the on-board analogue sensors preventing them loading the pins when not used.

P10 is a connector for jumper to connect VCC from the demonstration board back to the programmer/EB.

For detailed signal description, please refer to the pinout shown in the data sheet.

Push buttons

The Demonstration Board is furnished with 6 push buttons connected to the following I/O signals:

Demo Board marking	RC2300 module pin
S1	P0.1
S2	P0.6
S3	P1.2
S4	P1.3
S5	P2.0
S7	RESET. Pressing this button will activate the main RESET of the module

LEDs

The Demonstration Board is furnished with one green power indicator LED, two LEDs indicating UART activity as described above, and 2 LEDs connected to general I/O signals:

Demo Board marking	LED color and RC2300 module pin
D3	Green: P1.0
D6	Red: P1.1

Accelerometer

The accelerometer can be used measure movements in 2-axis, it can also be used for tilt measurement by measuring the earths gravitation. Accelerometer self test can be initiated by shorting test point T1 to ground. The accelerometer has a 20 ms start-up time after power on. See the Analog Devices ADXL321 datasheet for details about the accelerometer.

Potentiometer

The potentiometer is connected as a voltage divider between supply voltage and ground. Turning the knob clock-wise gives maximum voltage.

Light sensor

A light dependent resistor (LDR) measures the light level and gives an analogue signal that can be measured by the RC2300 A/D converter. The light sensor resistance ranges from 5K (light) to 20M (dark), and is connected a voltage divider together with a 200k Ohm resistor to the supply voltage. See the Silonex NSL-19M51 datasheet for details about the LDR.

Debug and programming interface

The Demonstration Board provides a DEBUG interface used to program firmware into the on-board module and for debugging the code. The DEBUG interface is compatible with the DEBUG interface at the TI / Chipcon SmartRF04EB board. This board and its associated software are available from TI / Chipcon. The table below shows the P8 SOC debug connector pin-out. A more easy-to-use USB dongle for firmware load will be available in the near future.

Debug interface pin	Function
1	GND
2	VCC (Insert jumper at P10 to connect VCC from target to the programmer/EB)
3	Debug Clock (DC)
4	Debug Data (DD)
5	CSn (optional)
6	SCL (optional)
7	RESET_N
8	MOSI (optional)
9	NC (not connected)
10	MISO (optional)

Below is shown how to connect the RC2300DB to the SmartRF04EB.

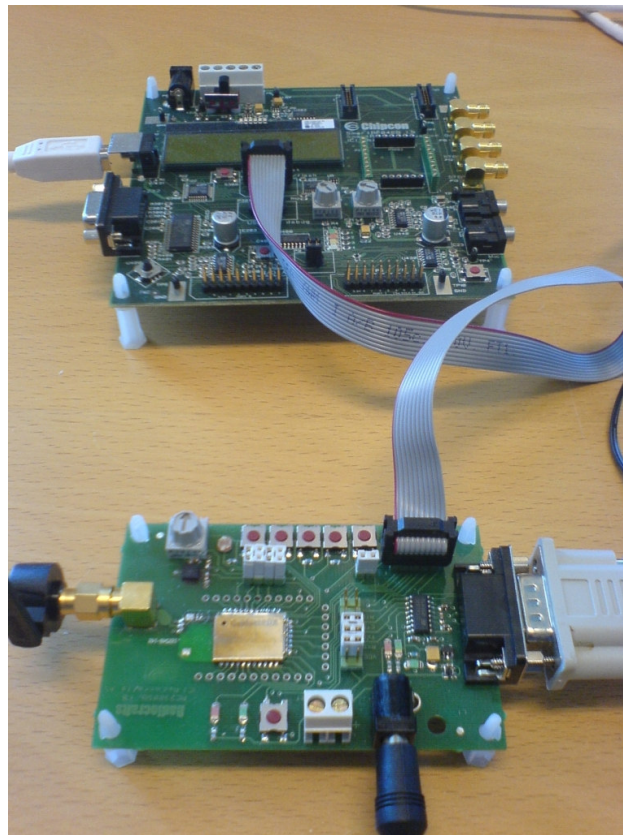

Figure 4. Debug interface connection

I/O mapping

The following table is a summary of the I/O mapping and their connection to the on-board resources. In the same table the pin usage for the TI/Chipcon CC2430DB is shown for reference.

I/O port	RC2300 pin	RC2300DB Demo Board	CC2430DB TI/Chipcon demo board
P0.0	8	Light dependent resistor (through jumper)	Light dependent resistor
P0.1	9	S1 push button	Push button
P0.2	10	I2C_SDA	EEPROM SDA
P0.3	11	I2C_SDL	EEPROM SCL
P0.4	12	Accelerometer x-axis (through jumper)	Accelerometer x-axis
P0.5	13	Accelerometer y-axis (through jumper)	Accelerometer y-axis
P0.6	14	S2 push button	Joystick analogue signal
P0.7	15	Potentiometer analogue input (through jumper)	Potentiometer analogue input
P1.0	29	D3, Green LED	Green LED
P1.1	28	D6, Red LED	Red LED
P1.2	27	S3 push button	Voltage control for I/O modules
P1.3	26	S4 push button	General purpose I/O
P1.4	25	CTS	CTS
P1.5	24	RTS	RTS
P1.6	23	TXD	TXD
P1.7	22	RXD	RXD
P2.0	5	S5 push button	Joystick push interrupt active high
P2.1	4	Debug data	Debug data
P2.2	3	Debug Clock	Debug Clock
RESET	6	S7 push button, RESET. Pressing this button will activate the main RESET of the module	RESET

Using the Demonstration Kit

The Demonstration Kit is useful for providing hands-on experience with the RC2300 for both software and hardware developers. The Data Sheet for the module provides detailed information on the internal resources and available I/Os of the modules.

Important: *The use of radio transceivers is regulated by international and national rules. Radiocrafts' modules meet the regulations in EU and US/Canada for different frequency variants. Make sure the local regulative are according to these rules. Your local telecommunication authorities can provide more information on use of un-licensed radio transmitter in your country.*

SW implementation

For implementing your application *IAR Embedded workbench* is recommended. En example IAR project for the embedded microcontroller can be downloaded from TI/Chipcon homepage. iUser guides for how to integrate module programming into IAR is also available there.

Circuit Diagram

The circuit diagram is shown below. A full resolution schematic is found in RC2300DB_1_0.zip (available from Radiocrafts' website).

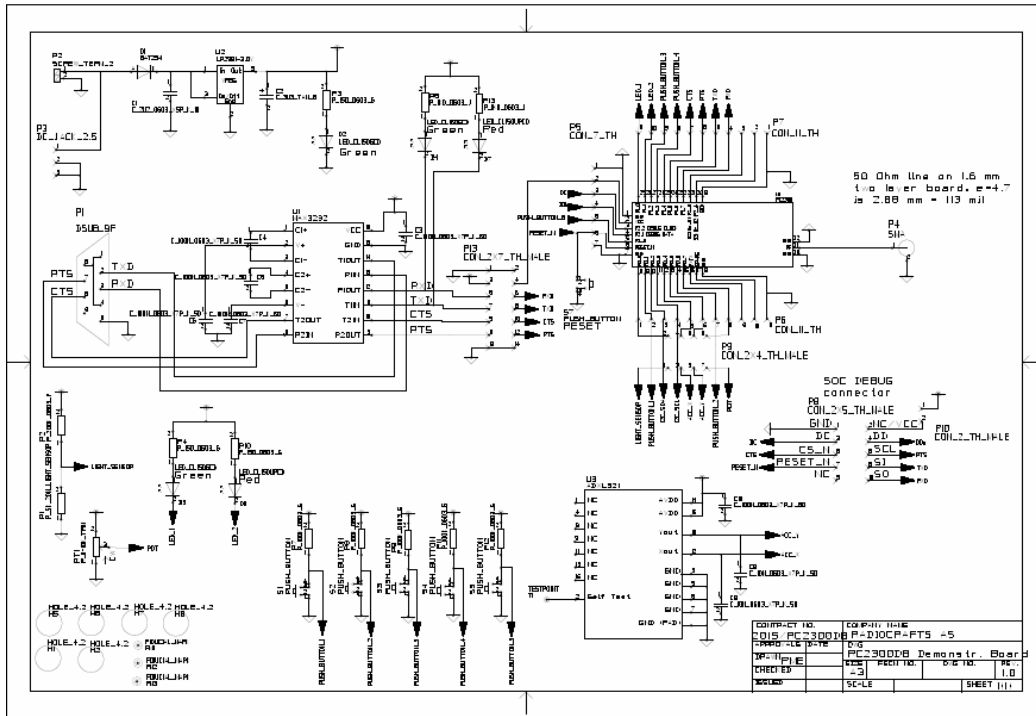

Bill of materials

<i>Reference</i>	<i>Quantity</i>	<i>Part number</i>	<i>Description</i>
C1	1	C_2U2_0603_X5R_K_10	Capacitor, 0603
C2	1	C_3U3_TAN_B	Capacitor, tantal
C3-7;C10	6	C_100N_0603_X7R_K_50	Capacitor, 0603
C8-9	2	C_10N_0603_X7R_K_50	Capacitor, 0603
D1	1	BAT254	Diode, Si
D2-4	3	LED_CL150GCD	LED, green, SMD
D6-7	2	LED_CL150URCD	LED, red, SMD
M1	1	RC2300AT	RF Module
P1	1	DSUB_9F	D-Sub, 9 pin, female
P2	1	SCREW_TERM_2	2 pin terminal, screw
P3	1	DC_JACK_2.5	DC jack, 2.5mm center pin
P4	1	SMA	SMA connector, straight Not populated
P8	1	CON_2X5_TH_MALE	Connector 10 pins, pin header
P9	1	CON_2X4_TH_MALE	Connector 8 pins, pin header
P10	1	CON_2_TH_MALE	Connector 2 pins, pin header
P13	1	CON_2X10_TH_MALE	Connector 20 pins, pin header
R1	1	NSL-19M51	Light Sensitive Resistor, 5k-20M Ohm
R2	1	R_200K_0603_F	Resistor, 0603
R7-9;R11-12	5	R_100K_0603_G	Resistor, 0603
R3-4,R10	3	R_150_0603_G	Resistor, 0603
R5; R13	2	R_1K0_0603_J	Resistor, 0603
RT1	1	72PTR10K	Trimming pot, 10K, knob
S1-5, S7	7	PUSH_BUTTON	Push button, SMD
U1	1	MAX3232	RS-232 Transceiver, SO-16
U2	1	LP2980-3.0V	3.0V low drop-out regulator
U3	1	ADXL321	Dual-axis Accelerometer, QFN

PCB layout

The PCB is a simple 2-layer board where the bottom layer is used as ground plane. The laminate used is standard FR-4 board material. The PCB is 1.6mm thick. Full resolution layout and assembly drawing are found in RC2300DB_1_0.zip.

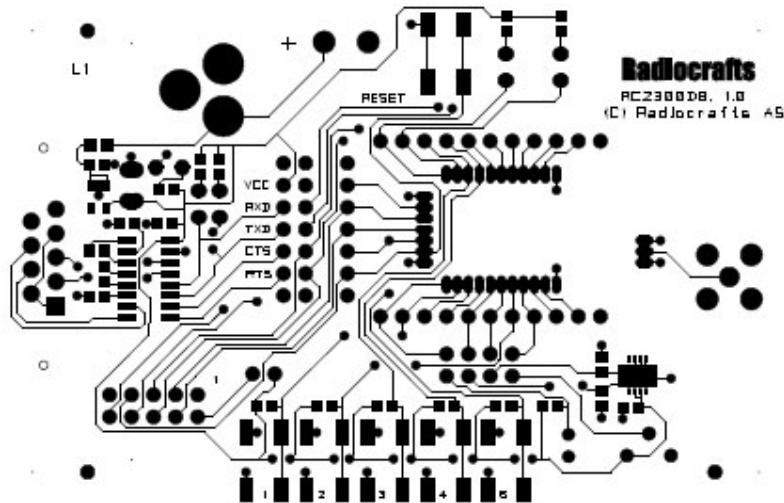

Figure 5: RC2300DB PCB layout, top layer (1)

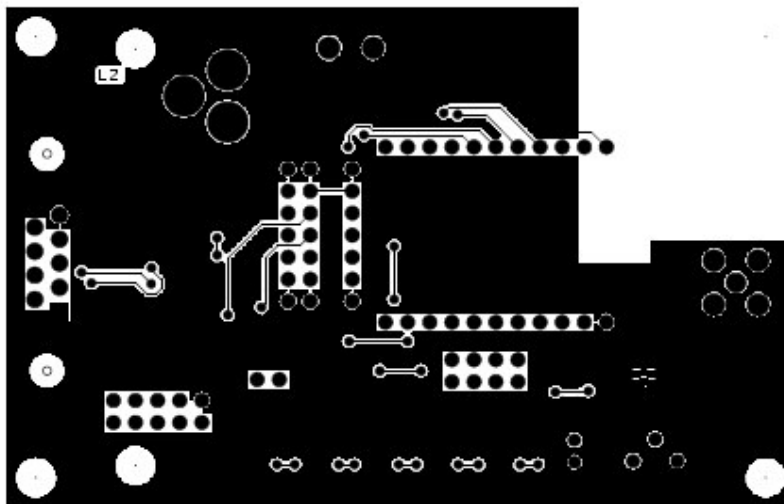

Figure 6: RC2300DB PCB layout, bottom layer (2)

Troubleshooting

It doesn't work

- First, measure the supply voltage at P13, pin 3. Should be 3.0V.
- Make sure that a jumper is installed or an ampere meter is connected between pin 3 and 4 on P13.
- Is the supply voltage correctly polarized? If not, the protection diode will prevent any current from flowing. + and – are indicated on the PCB, on the DC jack, the tip is + and the ring is –.
- Is the battery eliminator plugged into the wall socket?
- Was the wall socket plugged in first, then the DC-jack to ensure quick rise-time on VCC? If not the module may have to be reset after power on. Press the RESET button.
- Is the wall outlet at the rated voltage printed on the AC/DC battery eliminator (220V or 110V)?
- Is the module programmed with the proper firmware? If not use the TI / Chipcon SmartRF04EB DEBUG interface to load the firmware.

I cannot communicate with the RC2300 UART through the serial port

- Make sure that the RXD and TXD jumpers are inserted
- Make sure that you are using a correctly wired 1:1 cable (as the one provided with the kit)
- Make sure the PC (or host) is configured for the correct serial port
- Make sure the PC serial port settings are correct with respect to baud rate, data bits, stop bits, parity bits and handshake

Document Revision History

Document Revision	Changes
1.0	New document

Disclaimer

Radiocrafts AS believes the information contained herein is correct and accurate at the time of this printing. However, Radiocrafts AS reserves the right to make changes to this product without notice. Radiocrafts AS does not assume any responsibility for the use of the described product; neither does it convey any license under its patent rights, or the rights of others. The latest updates are available at the Radiocrafts website or by contacting Radiocrafts directly.

As far as possible, major changes of product specifications and functionality, will be stated in product specific Errata Notes published at the Radiocrafts website. Customers are encouraged to check regularly for the most recent updates on products and support tools.

Trademarks

SPPIO is a trademark of Radiocrafts AS. ZigBee is a registered trademark of the ZigBee Alliance.

All other trademarks, registered trademarks and product names are the sole property of their respective owners.

Life Support Policy

This Radiocrafts product is not designed for use in life support appliances, devices, or other systems where malfunction can reasonably be expected to result in significant personal injury to the user, or as a critical component in any life support device or system whose failure to perform can be reasonably expected to cause the failure of the life support device or system, or to affect its safety or effectiveness. Radiocrafts AS customers using or selling these products for use in such applications do so at their own risk and agree to fully indemnify Radiocrafts AS for any damages resulting from any improper use or sale.

© 2006, Radiocrafts AS. All rights reserved.

Contact Information

Web site: www.radiocrafts.com

Email: radiocrafts@radiocrafts.com

Address:

Radiocrafts AS
Sandakerveien 64
NO-0484 OSLO
NORWAY

Tel: +47 4000 5195

Fax: +47 22 71 29 15

E-mail: sales@radiocrafts.com