

Open Drain Output Sub-Microamp Comparators

Features

- Low Quiescent Current: 600 nA/comparator (typ.)
- Rail-to-Rail Input: $V_{SS}-0.3V$ to $V_{DD}+0.3V$
- Open Drain Output: $V_{OUT} \leq 10V$
- Propagation Delay 4 μs (typ)
- Wide Supply Voltage Range: 1.6V to 5.5V
- Available in Single, Dual, and Quad
- Chip Select (\overline{CS}) with MCP6548
- Low Switching Current
- Internal Hysteresis: 3.3 mV (typ)

Typical Applications

- Laptop Computers
- Mobile Phones
- Metering Systems
- Hand-held Electronics
- RC Timers
- Alarm and Monitoring Circuits
- Windowed Comparators
- Multi-vibrators

Related Devices

- CMOS/TTL Compatible Output: MCP6541/2/3/4

Description

The Microchip Technology, Inc. MCP6546/7/8/9 family of comparators is offered in single (MCP6546), single with chip select (MCP6548), dual (MCP6547) and quad (MCP6549) configurations. The outputs are open drain, and are capable of driving heavy DC or capacitive loads.

These comparators are optimized for low power, single-supply operation with greater than rail-to-rail input operation. The output limits supply current surges, and dynamic power consumption, while switching. The open drain output of the MCP6546/7/8/9 family, with a pull-up resistor, can be used as a level shifter for any desired voltage up to 10V, and in wired-OR logic. Input hysteresis eliminates output switching due to internal noise voltage, reducing current draw. These comparators operate with a single supply voltage as low as 1.6V and draw less than 1 μA /comparator of quiescent current.

The related MCP6541/2/3/4 family of comparators from Microchip has a push-pull output that supports rail-to-rail output swing, and interfaces with CMOS/TTL logic.

Typical Application Circuit

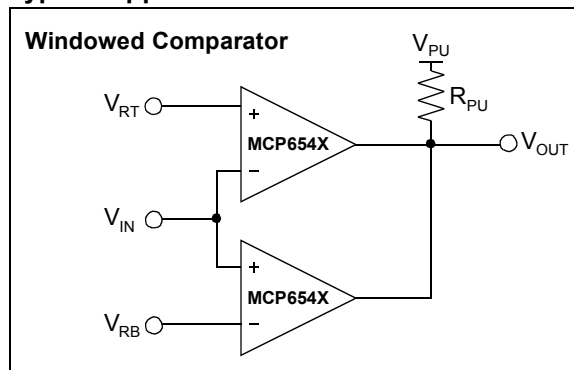

Package Types

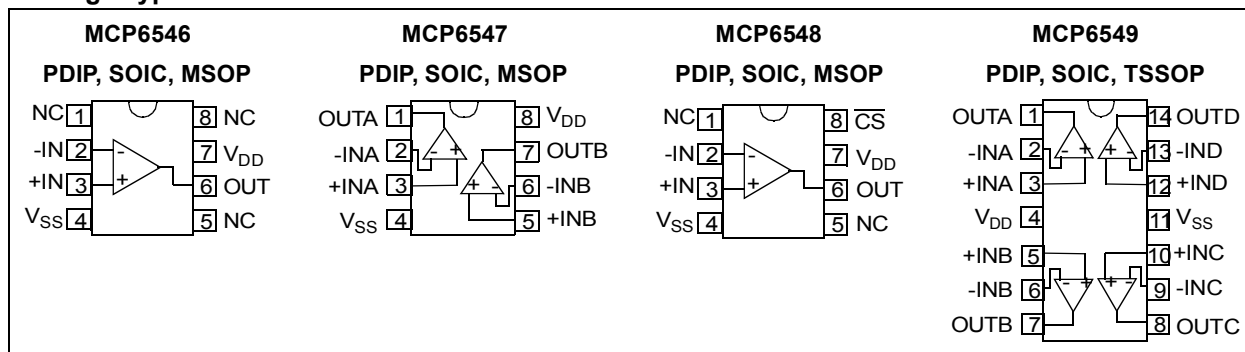

MCP6546/7/8/9

1.0 ELECTRICAL CHARACTERISTICS

1.1 Absolute Maximum Ratings*

$V_{DD} - V_{SS}$	7.0V
Open Drain output.....	$V_{SS} + 10.5V$
All inputs and outputs	$V_{SS} - 0.3V$ to $V_{DD} + 0.3V$
Difference Input voltage	$ V_{DD} - V_{SS} $
Output Short Circuit Current	continuous
Current at Input Pins	± 2 mA
Current at Output and Supply Pins	± 30 mA
Storage temperature	$-65^{\circ}C$ to $+150^{\circ}C$
Ambient temp. with power applied	$-55^{\circ}C$ to $+125^{\circ}C$
Junction temp.	$+150^{\circ}C$
ESD protection on all pins (HBM); (MM).....	4 kV; 400V

***Notice:** Stresses above those listed under "Maximum Ratings" may cause permanent damage to the device. This is a stress rating only and functional operation of the device at those or any other conditions above those indicated in the operational listings of this specification is not implied. Exposure to maximum rating conditions for extended periods may affect device reliability.

PIN FUNCTION TABLE

NAME	FUNCTION
+IN/+INA/+INB/+INC/+IND	Non-inverting Inputs
-IN/-INA/-INB/-INC/-IND	Inverting Inputs
V_{DD}	Positive Power Supply
V_{SS}	Negative Power Supply
OUT/OUTA/OUTB/OUTC/OUTD	Outputs
\overline{CS}	Chip Select

DC CHARACTERISTICS

Unless otherwise indicated, all limits are specified for: $V_{DD} = +1.6V$ to $+5.5V$, $V_{SS} = GND$, $T_A = 25^{\circ}C$, $V_{IN+} = V_{DD}/2$, $V_{IN-} = V_{SS}$, $R_{PU} = 2.74$ k Ω to $V_{PU} = V_{DD}$. Refer to Figure 1-3.

Parameters	Sym	Min	Typ	Max	Units	Conditions
Power Supply:						
Supply Voltage	V_{DD}	1.6	—	5.5	V	
Quiescent Current per comparator	I_Q	0.3	0.6	1.0	μA	$I_{OUT} = 0$
Input:						
Input Voltage Range	V_{CMR}	$V_{SS} - 0.3$	—	$V_{DD} + 0.3$	V	
Common-Mode Rejection Ratio	CMRR	55	70	—	dB	$V_{DD} = 5V$, $V_{CM} = -0.3V$ to $5.3V$
Common-Mode Rejection Ratio	CMRR	50	65	—	dB	$V_{DD} = 5V$, $V_{CM} = 2.5V$ to $5.3V$
Common-Mode Rejection Ratio	CMRR	55	70	—	dB	$V_{DD} = 5V$, $V_{CM} = -0.3V$ to $2.5V$
Power Supply Rejection Ratio	PSRR	63	80	—	dB	$V_{CM} = V_{SS}$
Input Offset Voltage	V_{OS}	-7.0	± 1.5	+7.0	mV	$V_{CM} = V_{SS}$ (Note 1)
Drift with Temperature	$\Delta V_{OS}/\Delta T$	—	± 3	—	$\mu V/^{\circ}C$	$T_A = -40^{\circ}C$ to $+85^{\circ}C$, $V_{CM} = V_{SS}$
Input Hysteresis Voltage	V_{HYST}	1.5	3.3	6.5	mV	$V_{CM} = V_{SS}$ (Note 1)
Drift with Temperature	$\Delta V_{HYST}/\Delta T$	—	10	—	$\mu V/^{\circ}C$	$T_A = -40^{\circ}C$ to $+25^{\circ}C$, $V_{CM} = V_{SS}$
Drift with Temperature	$\Delta V_{HYST}/\Delta T$	—	5	—	$\mu V/^{\circ}C$	$T_A = +25^{\circ}C$ to $+85^{\circ}C$, $V_{CM} = V_{SS}$
Input Bias Current	I_B	—	1	—	pA	$V_{CM} = V_{SS}$
Over Temperature	I_B	—	—	100	pA	$T_A = -40^{\circ}C$ to $+85^{\circ}C$, $V_{CM} = V_{SS}$
Input Offset Current	I_{OS}	—	± 1	—	pA	$V_{CM} = V_{SS}$
Common Mode Input Impedance	Z_{CM}	—	$10^{13} 4$	—	ΩpF	
Differential Input Impedance	Z_{DIFF}	—	$10^{13} 2$	—	ΩpF	
Open Drain Output:						
Output Pull-Up Voltage	V_{PU}	V_{DD}	—	10	V	(Note 2)
High Level Output Current	I_{OH}	-100	—	—	nA	$V_{DD} = 1.6V$ to $5.5V$, $V_{PU} = 10V$ (Note 2)
Low Level Output Voltage	V_{OL}	V_{SS}	—	$V_{SS} + 0.2$	V	$I_{OUT} = 2$ mA, $V_{PU} = V_{DD} = 5V$
Short Circuit Current	I_{SC}	—	± 50	—	mA	$V_{PU} = V_{DD} = 5.0V$ (Note 2)
Output Pin Capacitance	C_{OUT}	—	8	—	pF	

Note 1: The input offset voltage is the center of the input-referred trip points. The input hysteresis is the difference between the input-referred trip points.

2: Do not short the output about $V_{SS} + 10V$. Limit the output current to Absolute Maximum Rating of 30 mA. The comparator does not function properly when $V_{PU} < V_{DD}$.

AC CHARACTERISTICS

Unless otherwise indicated, all limits are specified for: $V_{DD} = +1.6V$ to $+5.5V$, $V_{SS} = GND$, $T_A = 25^\circ C$, $V_{IN+} = V_{DD}/2$, Step = 200 mV, Overdrive = 100 mV, $R_{PU} = 2.74 k\Omega$ to $V_{PU} = V_{DD}$, and $C_L = 36 pF$. Refer to Figure 1-2 and Figure 1-3.

Parameters	Sym	Min	Typ	Max	Units	Conditions
Fall Time	t_F	—	0.7	—	μs	(Note 1)
Propagation Delay (High to Low)	t_{PHL}	—	4.0	8.0	μs	(Note 1)
Propagation Delay (Low to High)	t_{PLH}	—	3.0	8.0	μs	
Propagation Delay Skew	t_{PDS}	—	-1.0	—	μs	
Maximum Toggle Frequency	f_{MAX}	—	225	—	kHz	$V_{DD} = 1.6V$
	f_{MAX}	—	165	—	kHz	$V_{DD} = 5.5V$
Input Noise Voltage	E_N	—	200	—	μV_{P-P}	10 Hz to 100 kHz

Note 1: t_R and t_{PLH} depend on the load (R_L and C_L); these specifications are valid for the indicated load only.

2: Propagation Delay Skew is defined as: $t_{PDS} = t_{PLH} - t_{PHL}$.

SPECIFICATIONS FOR MCP6548 CHIP SELECT

Unless otherwise indicated, all limits are specified for: $V_{DD} = +1.6V$ to $+5.5V$, $V_{SS} = GND$, $T_A = 25^\circ C$, $V_{IN+} = V_{DD}/2$, $V_{IN-} = V_{SS}$, $R_{PU} = 2.74 k\Omega$ to $V_{PU} = V_{DD}$, and $C_L = 36 pF$. Refer to Figure 1-3.

Parameters	Sym	Min	Typ	Max	Units	Conditions
\overline{CS} Low Specifications:						
\overline{CS} Logic Threshold, Low	V_{IL}	V_{SS}	—	$0.2V_{DD}$	V	
\overline{CS} Input Current, Low	I_{CSL}	—	0.005	—	nA	$\overline{CS} = V_{SS}$
\overline{CS} High Specifications:						
\overline{CS} Logic Threshold, High	V_{IH}	$0.8V_{DD}$	—	V_{DD}	V	
\overline{CS} Input Current, High	I_{CSH}	—	0.005	—	nA	$\overline{CS} = V_{DD}$
\overline{CS} Input High, GND Current	I_{SS}	—	0.02	—	nA	$\overline{CS} = V_{DD}$
Comparator Output Leakage	$I_{O(LEAK)}$	—	20	—	pA	$V_{OUT} = V_{SS} + 10V$
\overline{CS} Dynamic Specifications:						
\overline{CS} Low to Comparator Output Low Turn-on Time	t_{ON}	—	2	50	ms	$\overline{CS} = 0.2V_{DD}$ to $V_{OUT} = V_{DD}/2$, $V_{IN-} = V_{DD}$
\overline{CS} High to Comparator Output High Z Turn-off Time	t_{OFF}	—	10	—	μs	$\overline{CS} = 0.8V_{DD}$ to $V_{OUT} = V_{DD}/2$, $V_{IN-} = V_{DD}$
\overline{CS} Hysteresis	V_{CS_HYST}	—	0.6	—	V	$V_{DD} = 5V$

MCP6546/7/8/9

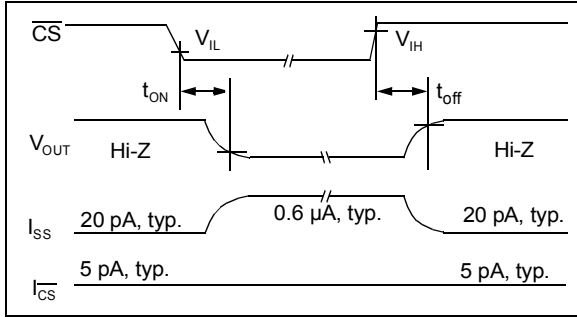

FIGURE 1-1: Timing Diagram for the $\overline{\text{CS}}$ pin on the MCP6548.

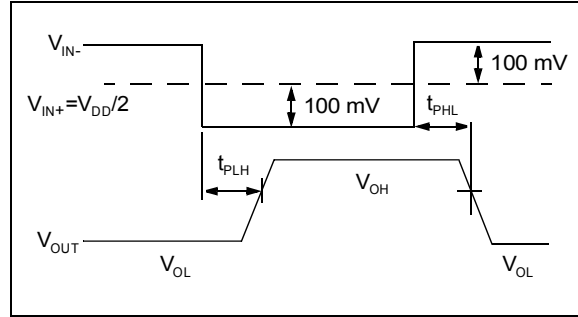

FIGURE 1-2: Propagation Delay Timing diagram.

TEMPERATURE SPECIFICATIONS

Unless otherwise indicated, all limits are specified for: $V_{DD} = +1.6\text{V to }+5.5\text{V}$ and $V_{SS} = \text{GND}$.

Parameters	Sym	Min	Typ	Max	Units	Conditions
Temperature Ranges						
Specified Temperature Range	T_A	-40	—	+85	$^{\circ}\text{C}$	
Storage Temperature Range	T_A	-65	—	+150	$^{\circ}\text{C}$	
Thermal Package Resistances						
Thermal Resistance, 8L-PDIP	θ_{JA}	—	85	—	$^{\circ}\text{C/W}$	
Thermal Resistance, 8L-SOIC	θ_{JA}	—	163	—	$^{\circ}\text{C/W}$	
Thermal Resistance, 8L-MSOP	θ_{JA}	—	206	—	$^{\circ}\text{C/W}$	
Thermal Resistance, 14L-PDIP	θ_{JA}	—	70	—	$^{\circ}\text{C/W}$	
Thermal Resistance, 14L-SOIC	θ_{JA}	—	120	—	$^{\circ}\text{C/W}$	
Thermal Resistance, 14L-TSSOP	θ_{JA}	—	100	—	$^{\circ}\text{C/W}$	

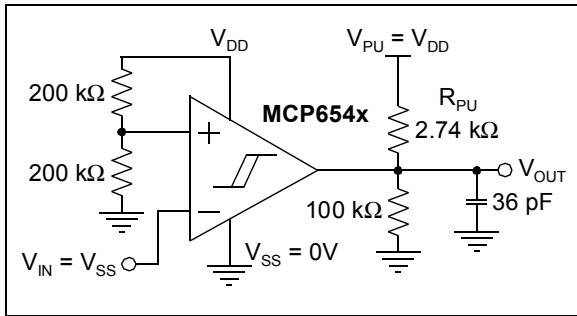

FIGURE 1-3: DC Test circuit for the open drain output comparators.

2.0 TYPICAL PERFORMANCE CURVES

Note: The graphs and tables provided following this note are a statistical summary based on a limited number of samples and are provided for informational purposes only. The performance characteristics listed herein are not tested or guaranteed. In some graphs or tables, the data presented may be outside the specified operating range (e.g., outside specified power supply range) and therefore outside the warranted range.

Note: Unless otherwise indicated, $V_{DD} = +5.0V$, $V_{SS} = GND$, $T_A = 25^\circ C$, $V_{IN+} = V_{DD}/2$, $V_{IN-} = GND$, $R_{PU} = 2.74\ k\Omega$ $V_{PU} = V_{DD}$, and $C_L = 36\ pF$.

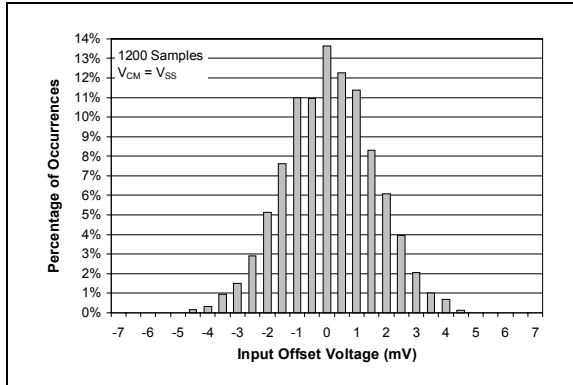

FIGURE 2-1: Histogram of Input Offset Voltage with $V_{CM} = V_{SS}$.

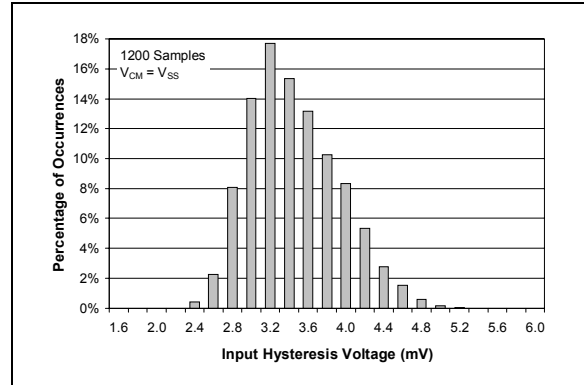

FIGURE 2-4: Histogram of Input Hysteresis Voltage with $V_{CM} = V_{SS}$.

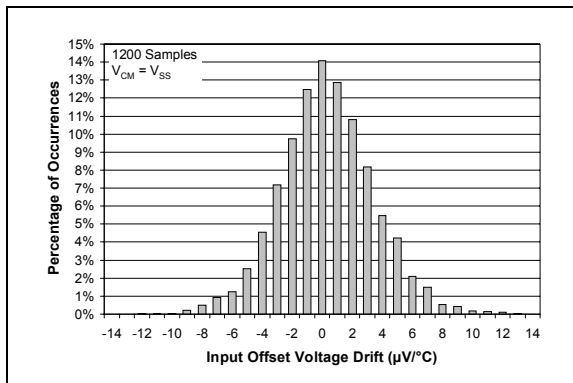

FIGURE 2-2: Histogram of Input Offset Voltage Drift with $V_{CM} = V_{SS}$.

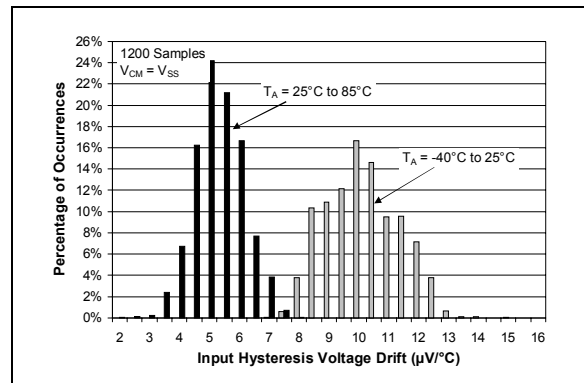

FIGURE 2-5: Histogram of Input Hysteresis Voltage Drift with Temperature = $-40^\circ C$ to $25^\circ C$ and $25^\circ C$ to $85^\circ C$, $V_{CM} = V_{SS}$.

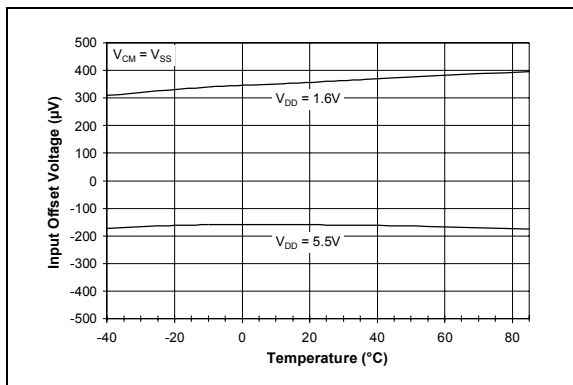

FIGURE 2-3: Input Offset Voltage vs. Temperature vs. Power Supply Voltage with $V_{CM} = V_{SS}$.

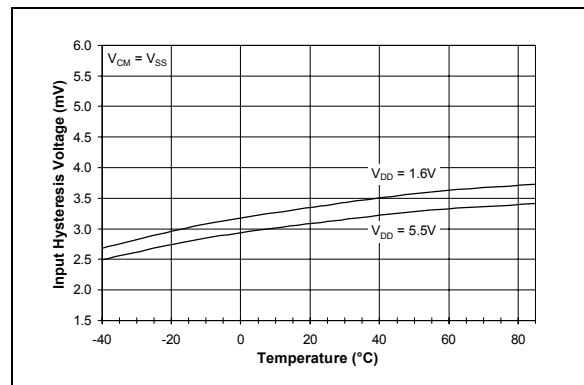

FIGURE 2-6: Input Hysteresis Voltage vs. Temperature vs. Power Supply Voltage with $V_{CM} = V_{SS}$.

MCP6546/7/8/9

Note: Unless otherwise indicated, $V_{DD} = +5.0V$, $V_{SS} = GND$, $T_A = 25^\circ C$, $V_{IN+} = V_{DD}/2$, $V_{IN-} = GND$, $R_{PU} = 2.74\text{ k}\Omega$ to $V_{PU} = V_{DD}$, and $C_L = 36\text{ pF}$.

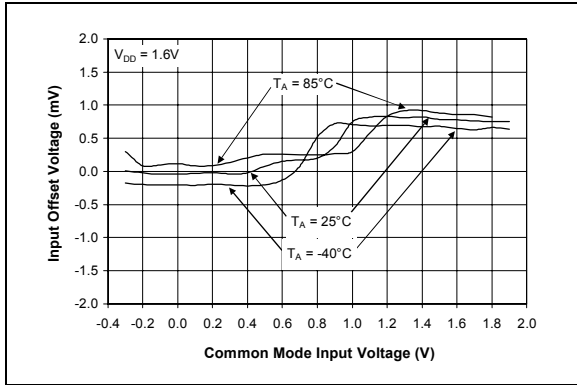

FIGURE 2-7: Input Offset Voltage vs. Common Mode Input Voltage vs. Temperature with $V_{DD} = 1.6V$.

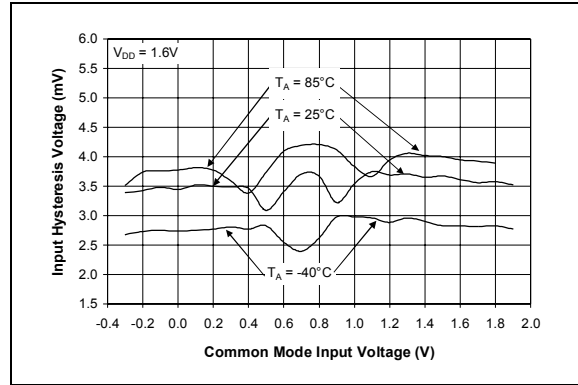

FIGURE 2-10: Input Hysteresis Voltage vs. Common Mode Input Voltage vs. Temperature with $V_{DD} = 1.6V$.

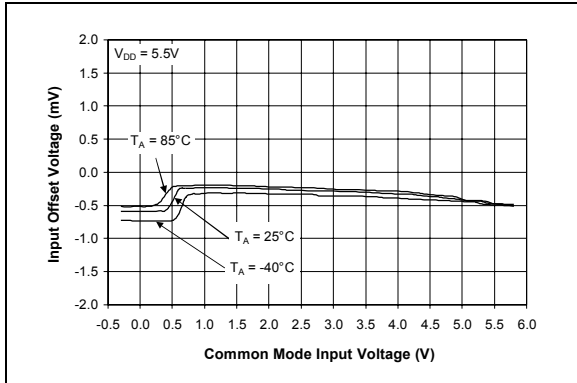

FIGURE 2-8: Input Offset Voltage vs. Common Mode Input Voltage vs. Temperature with $V_{DD} = 5.5V$.

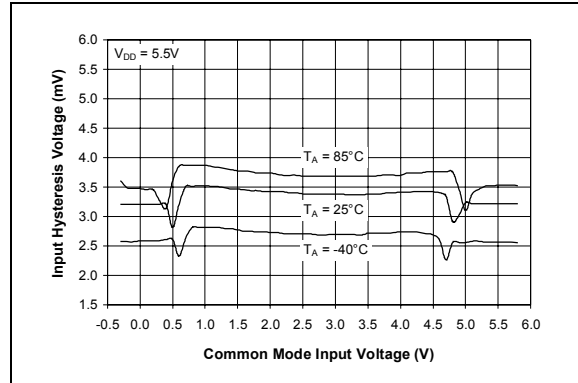

FIGURE 2-11: Input Hysteresis Voltage vs. Common Mode Input Voltage vs. Temperature with $V_{DD} = 5.5V$.

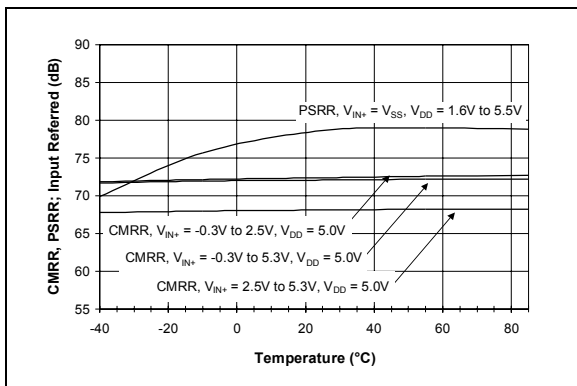

FIGURE 2-9: Common Mode Rejection Ratio, Power Supply Rejection Ratio vs. Temperature with $V_{CM} = V_{SS}$.

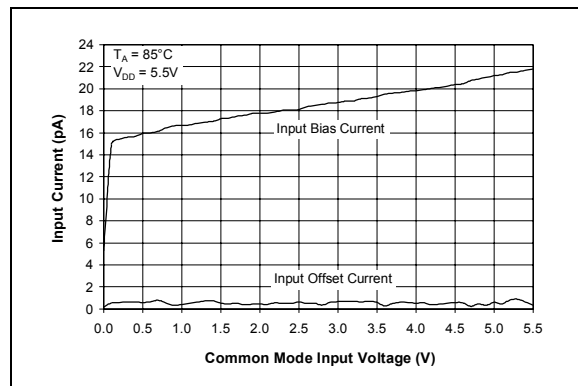

FIGURE 2-12: Input Bias Current, Input Offset Current vs. Common Mode Input Voltage with Temperature = $85^\circ C$.

Note: Unless otherwise indicated, $V_{DD} = +5.0V$, $V_{SS} = GND$, $T_A = 25^\circ C$, $V_{IN+} = V_{DD}/2$, $V_{IN-} = GND$, $R_{PU} = 2.74\text{ k}\Omega$ to $V_{PU} = V_{DD}$, and $C_L = 36\text{ pF}$.

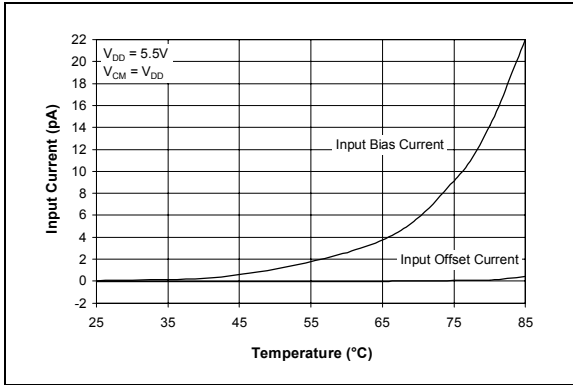

FIGURE 2-13: Input Bias Current, Input Offset Current vs. Temperature.

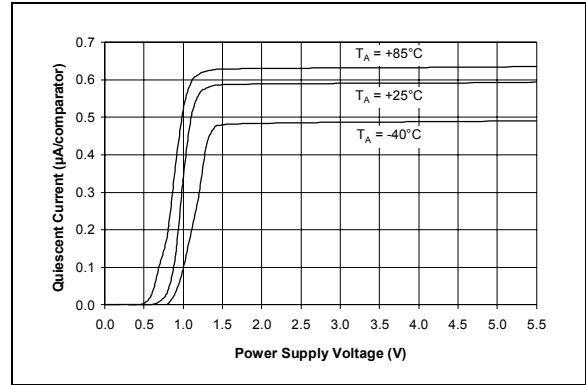

FIGURE 2-16: Quiescent Current vs. Power Supply Voltage vs. Temperature.

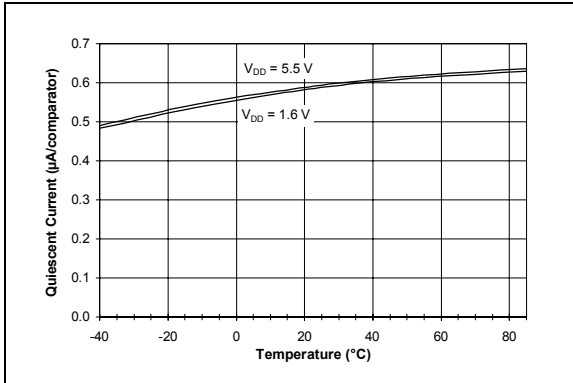

FIGURE 2-14: Quiescent Current vs. Temperature vs. Power Supply Voltage.

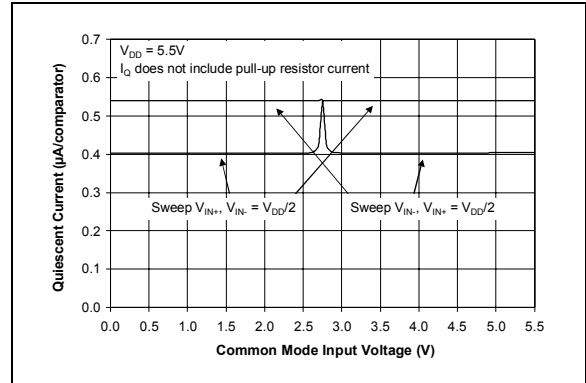

FIGURE 2-17: Quiescent Current vs. Common Mode Input Voltage with $V_{DD} = 5V$.

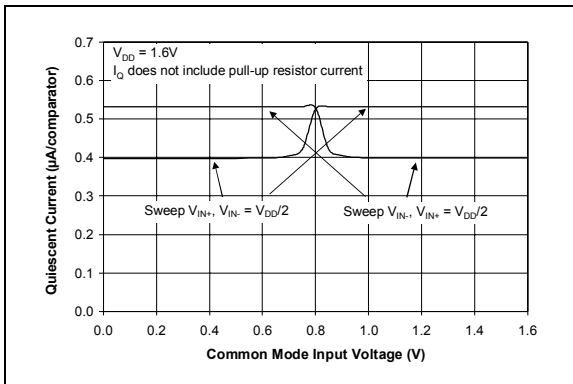

FIGURE 2-15: Quiescent Current vs. Common Mode Input Voltage with $V_{DD} = 1.6V$.

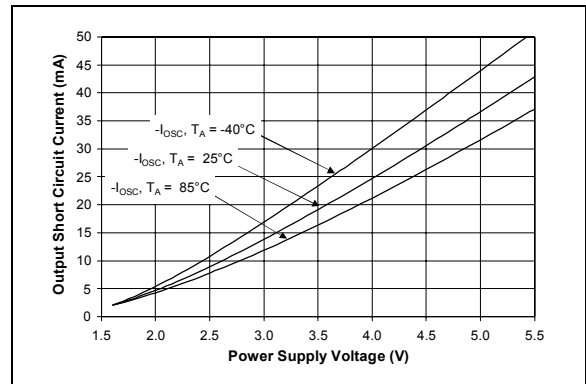

FIGURE 2-18: Output Short Circuit Current vs. Power Supply Voltage vs. Temperature.

MCP6546/7/8/9

Note: Unless otherwise indicated, $V_{DD} = +5.0V$, $V_{SS} = GND$, $T_A = 25^\circ C$, $V_{IN+} = V_{DD}/2$, $V_{IN-} = GND$, $R_{PU} = 2.74\text{ k}\Omega$ to $V_{PU} = V_{DD}$, and $C_L = 36\text{ pF}$.

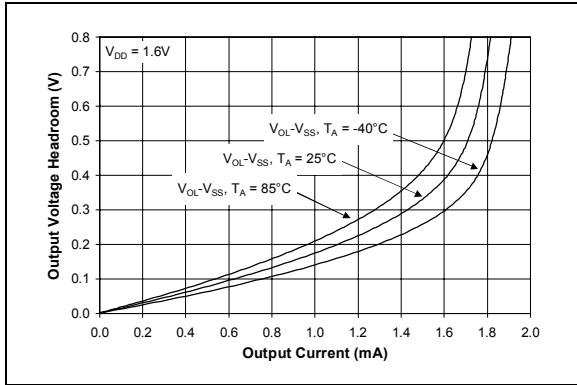

FIGURE 2-19: Output Voltage Headroom vs. Output Current vs. Temperature with $V_{DD} = 1.6V$.

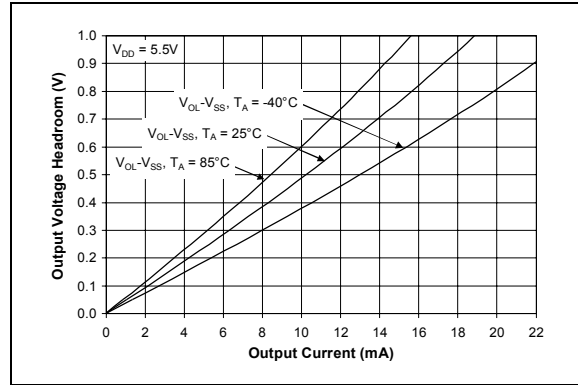

FIGURE 2-22: Output Voltage Headroom vs. Output Current vs. Temperature with $V_{DD} = 5.5V$.

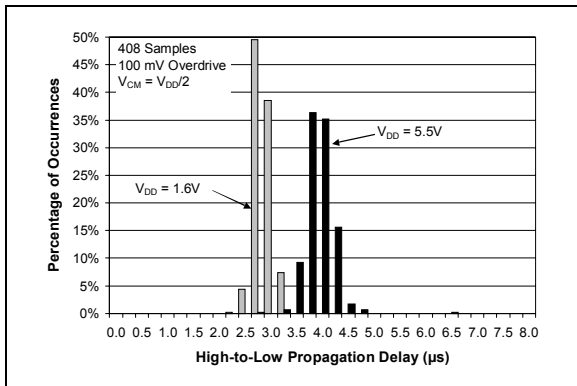

FIGURE 2-20: Histogram of High-to-Low Propagation Delay with $V_{DD} = 1.6V$ and $5.5V$.

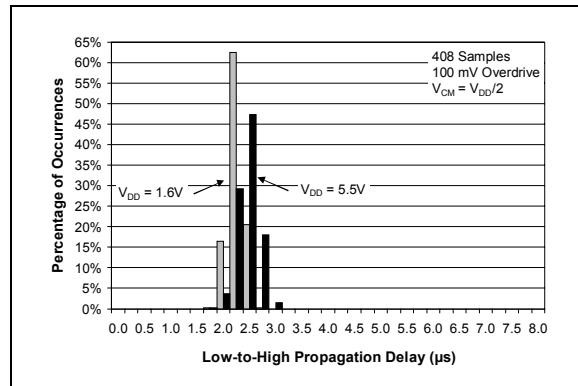

FIGURE 2-23: Histogram of Low-to-High Propagation Delay with $V_{DD} = 1.6V$ and $5.5V$.

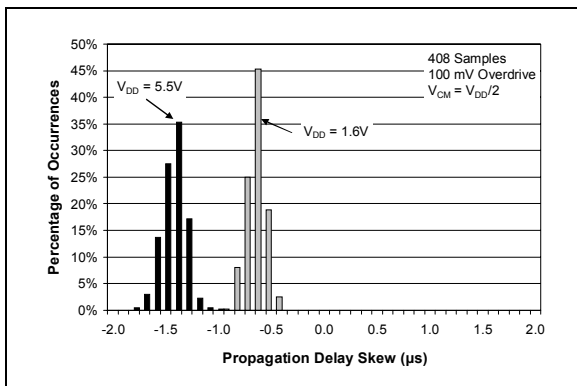

FIGURE 2-21: Histogram of Propagation Delay Skew with $V_{DD} = 1.6V$ and $5.5V$.

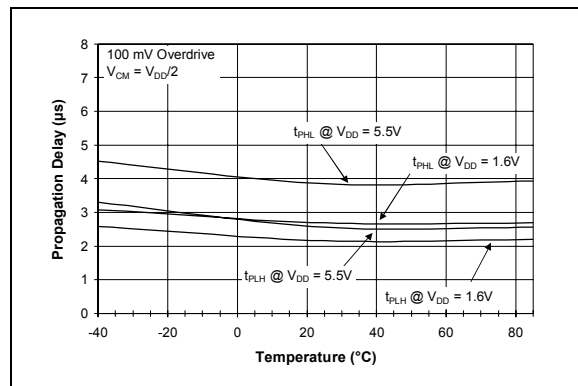

FIGURE 2-24: Propagation Delay vs. Temperature vs. Power Supply Voltage.

Note: Unless otherwise indicated, $V_{DD} = +5.0V$, $V_{SS} = GND$, $T_A = 25^\circ C$, $V_{IN+} = V_{DD}/2$, $V_{IN-} = GND$, $R_{PU} = 2.74\text{ k}\Omega$ to $V_{PU} = V_{DD}$, and $C_L = 36\text{ pF}$.

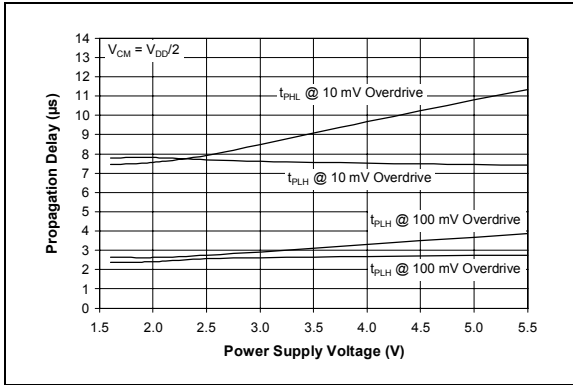

FIGURE 2-25: Propagation Delay vs. Power Supply Voltage vs. Input Overdrive.

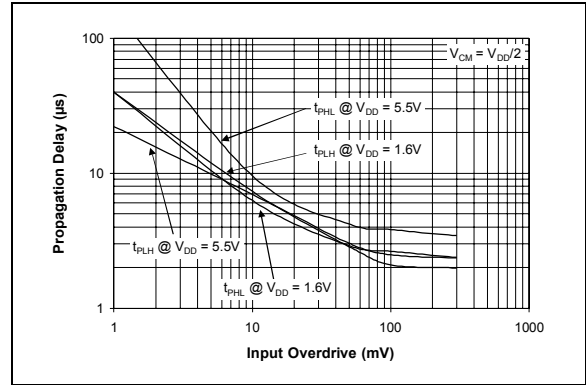

FIGURE 2-28: Propagation Delay vs. Input Overdrive vs. Power Supply Voltage.

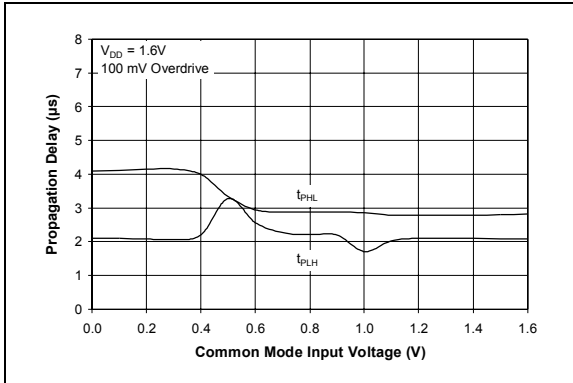

FIGURE 2-26: Propagation Delay vs. Common Mode Input Voltage with $V_{DD} = 1.6V$.

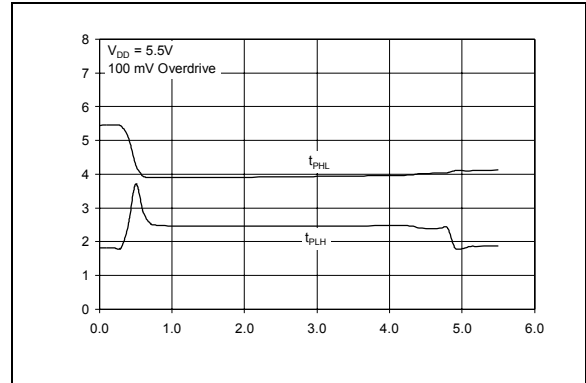

FIGURE 2-29: Propagation Delay vs. Common Mode Input Voltage with $V_{DD} = 5.5V$.

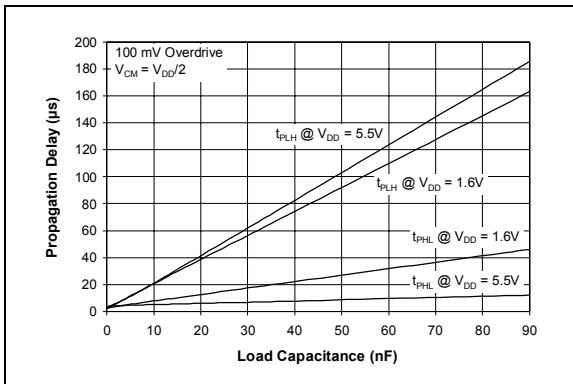

FIGURE 2-27: Propagation Delay vs. Load Capacitance vs. Power Supply Voltage.

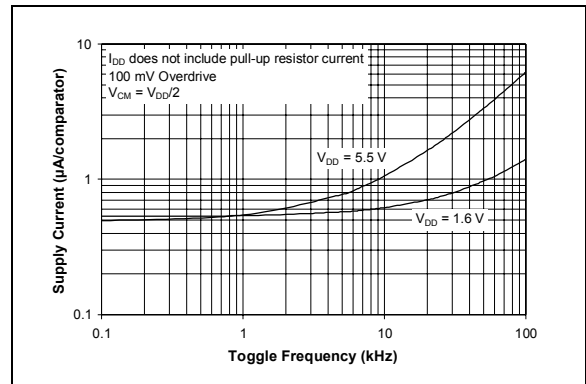

FIGURE 2-30: Supply Current vs. Toggle Frequency vs. Power Supply Voltage.

MCP6546/7/8/9

Note: Unless otherwise indicated, $V_{DD} = +5.0V$, $V_{SS} = GND$, $T_A = 25^\circ C$, $V_{IN+} = V_{DD}/2$, $V_{IN-} = GND$, $R_{PU} = 2.74\text{ k}\Omega$ to $V_{PU} = V_{DD}$, and $C_L = 36\text{ pF}$.

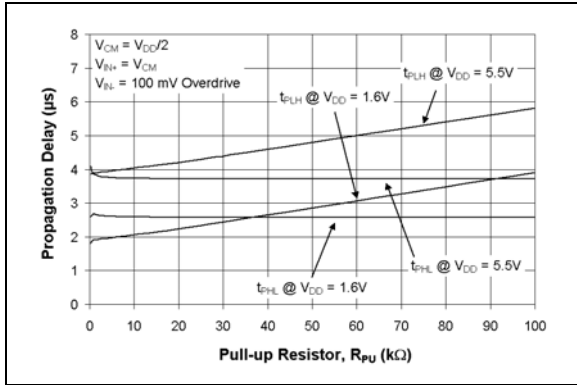

FIGURE 2-31: Propagation Delay vs. Pull-up Resistor vs. Power Supply Voltage.

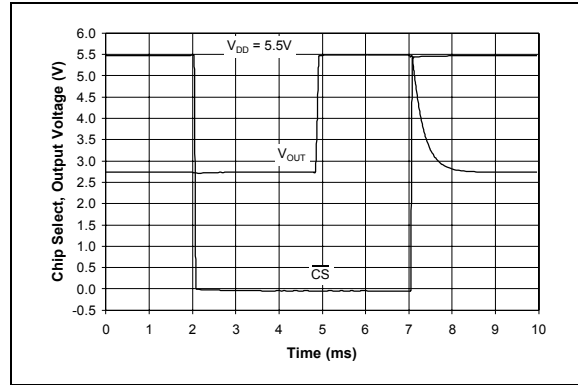

FIGURE 2-34: Chip Select (\overline{CS}) Step Response (MCP6548 only).

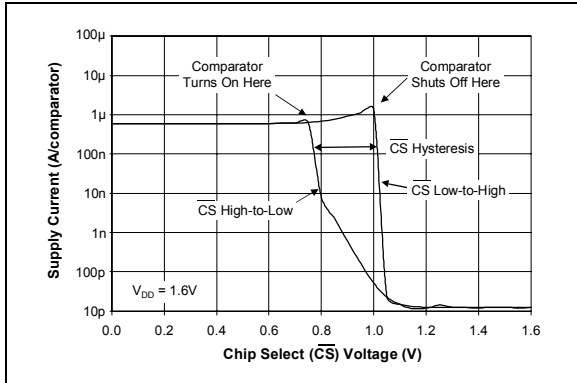

FIGURE 2-32: Supply Current (shoot through current) vs. Chip Select (\overline{CS}) Voltage with $V_{DD} = 1.6V$ (MCP6548 only).

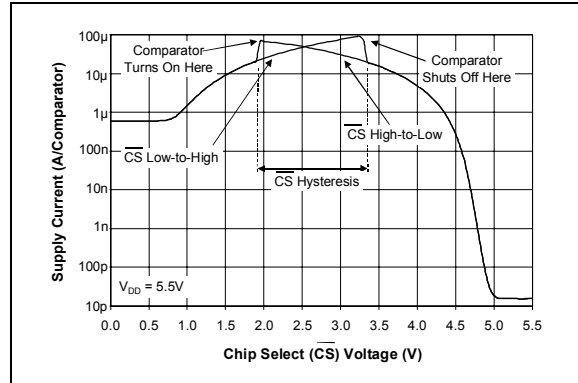

FIGURE 2-35: Supply Current (shoot through current) vs. Chip Select (\overline{CS}) Voltage with $V_{DD} = 5.5V$ (MCP6548 only).

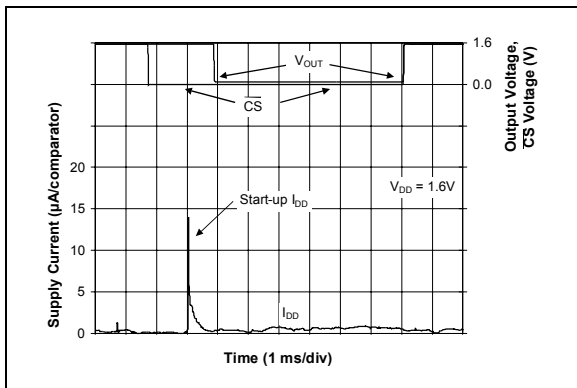

FIGURE 2-33: Supply Current (charging current) vs. Chip Select (\overline{CS}) pulse with $V_{DD} = 1.6V$ (MCP6548 only).

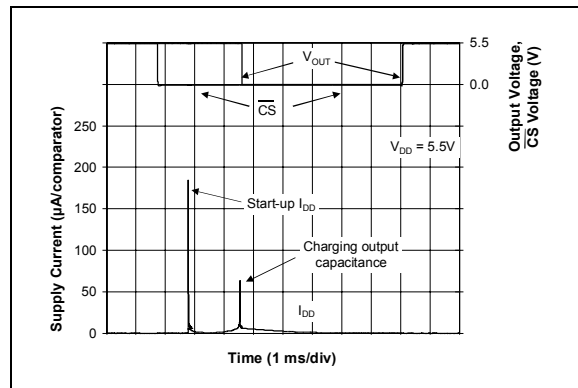

FIGURE 2-36: Supply Current (charging current) vs. Chip Select (\overline{CS}) pulse with $V_{DD} = 5.5V$ (MCP6548 only).

Note: Unless otherwise indicated, $V_{DD} = +5.0V$, $V_{SS} = GND$, $T_A = 25^\circ C$, $V_{IN+} = V_{DD}/2$, $V_{IN-} = GND$, $R_{PU} = 2.74 k\Omega$ to $V_{PU} = V_{DD}$, and $C_L = 36 pF$.

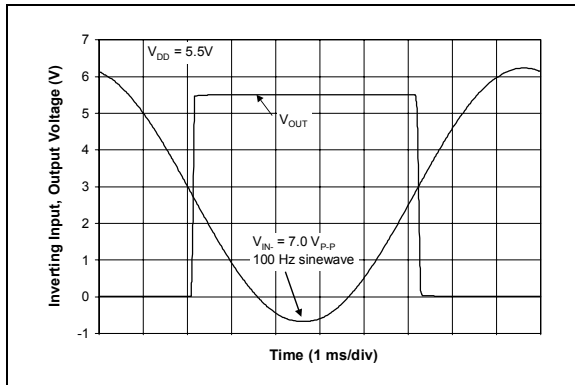

FIGURE 2-37: The MCP6546/7/8/9 comparators show no phase reversal.

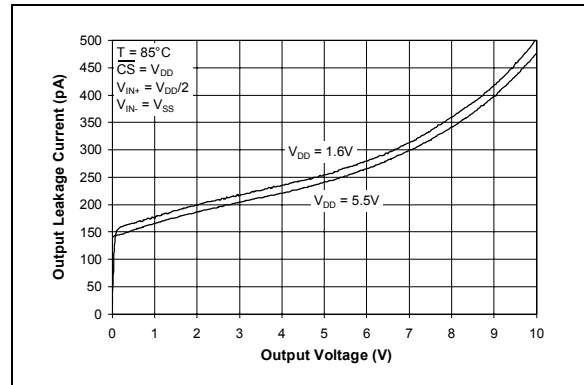

FIGURE 2-38: Output Leakage Current ($\overline{CS} = V_{DD}$) vs. Output Voltage vs. Power Supply Voltage (MCP6548 only)

MCP6546/7/8/9

3.0 APPLICATIONS INFORMATION

The MCP6546/7/8/9 family of open drain output comparators are fabricated on Microchip's state of the art CMOS process. They are suitable for a wide range of applications requiring very low power consumption. The power supply pin needs to be by-passed with a 0.1 μF capacitor.

3.1 Rail to Rail Input

The input stage of this family of devices uses two differential input stages in parallel: one operates at low input voltages, and the other at high input voltages. With this topology, the family operates to 0.3V past both rails. The input offset voltage is measured at both $V_{SS}-0.3\text{V}$ and $V_{DD}+0.3\text{V}$ to ensure proper operation.

3.2 Input Voltage and Phase Reversal

The comparator family uses CMOS transistors at the input. They are designed to not exhibit phase inversion when the input pins exceed the supply voltages. Figure 2-37 shows an input voltage exceeding both supplies with no resulting phase inversion.

The maximum operating input voltages that can be applied are $V_{SS}-0.3\text{V}$ and $V_{DD}+0.3\text{V}$. Voltages on the inputs that exceed this absolute maximum rating can cause excessive current to flow in or out of the input pins. Current beyond $\pm 2\text{ mA}$ can cause possible reliability problems. Applications that exceed this rating must be externally limited with an input resistor as shown in Figure 3-1.

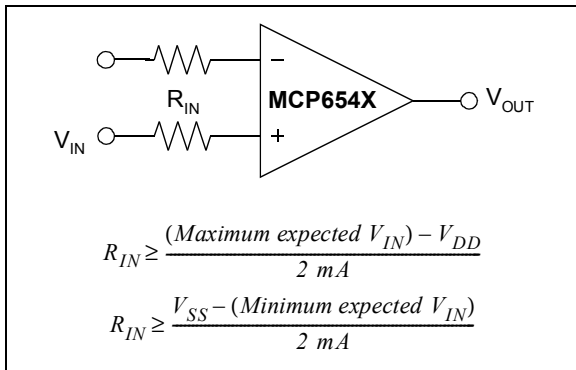

FIGURE 3-1: An input resistor (R_{IN}) should be used to limit excessive input current if either of the inputs exceeds the Absolute Maximum specification.

3.3 Hysteresis

Input offset voltage (V_{OS}) is the center (average) of the (input referred) low-high and high-low trip points. Input hysteresis voltage (V_{HYST}) is the difference between the same trip points. Hysteresis reduces output chattering when one input is slowly moving past the other, and thus reduces dynamic supply current. It also helps in systems where it is best not to cycle between states too frequently (e.g., air conditioner thermostatic control).

The family has internally set hysteresis which is small enough to maintain input offset accuracy ($<7\text{ mV}$), and large enough to eliminate output chattering caused by the comparator's own input noise voltage (200 $\mu\text{Vp-p}$).

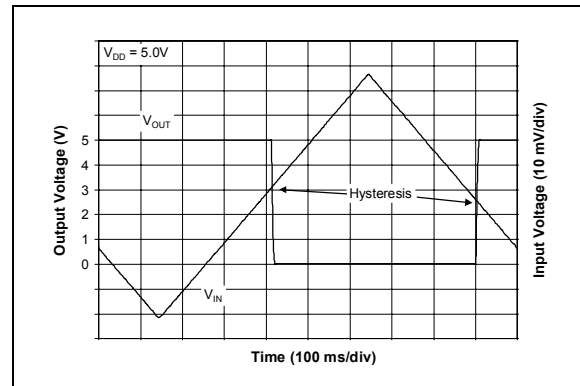

FIGURE 3-2: The MCP6546/7/8/9 comparators' internal hysteresis eliminates output chatter caused by input noise voltage.

3.3.1 INVERTING CIRCUIT

Figure 3-3 shows an inverting circuit for single supply using three resistors, besides the pull-up resistor. The resulting hysteresis diagram is shown in Figure 3-4.

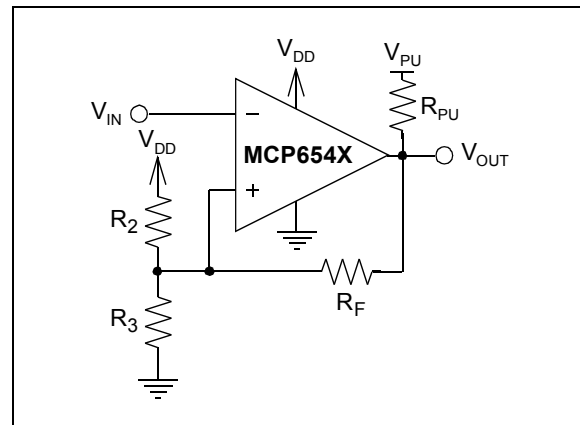

FIGURE 3-3: Inverting circuit with hysteresis.

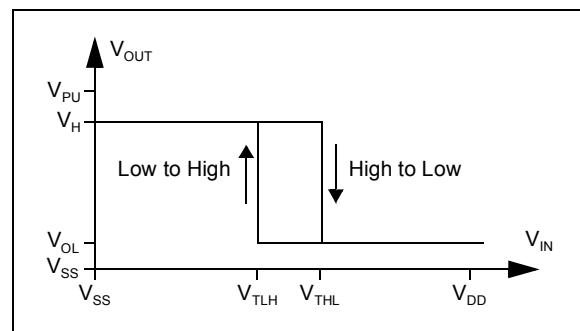

FIGURE 3-4: Hysteresis diagram for the inverting circuit.

The trip points for Figures 3-3 and 3-4 are given by:

$$R_{23} = R_2 \parallel R_3$$

$$V_{REF} = V_{DD} \left(\frac{R_3}{R_2 + R_3} \right)$$

$$V_H = V_{PU} \left(\frac{R_{23} + R_F}{R_{23} + R_F + R_{PU}} \right)$$

$$V_{THL} = V_{PU} \left(\frac{R_{23}}{R_{23} + R_F + R_{PU}} \right) + V_{REF} \left(\frac{R_F + R_{PU}}{R_{23} + R_F + R_{PU}} \right)$$

$$V_{TLH} = V_{OL} \left(\frac{R_{23}}{R_{23} + R_F} \right) + V_{REF} \left(\frac{R_F}{R_{23} + R_F} \right)$$

The output current required to drive V_{OL} is:

$$I_O = \frac{V_{PU} - V_{OL}}{R_{PU}} + \frac{V_{REF} - V_{OL}}{R_{23} + R_F}$$

As explained in Section 3.2, it is important to keep the non-inverting input below $V_{DD} + 0.3V$ when $V_{PU} > V_{DD}$.

3.4 The MCP6548 Chip Select (\overline{CS}) Option

The MCP6548 is a single comparator with a chip select (\overline{CS}) option. When \overline{CS} is pulled high, the supply current drops to 20 pA (typ), and goes through the \overline{CS} pin to V_{SS} . When this happens, the comparator output is put into a high impedance state. By pulling \overline{CS} low, the comparator is enabled. If the \overline{CS} pin is left floating, the comparator will not operate properly. Figure 1-1 shows the output voltage and supply current response to a \overline{CS} pulse.

The internal \overline{CS} circuitry is designed to minimize glitches when cycling the \overline{CS} pin. This helps conserve power, which is especially important in battery powered applications.

3.5 Open Drain Output

The open drain output is designed to make level shifting and wired-OR logic easy to implement. The output can go as high as 10V for 9V battery-powered applications. The output stage minimizes switching current (shoot through current from supply to supply) when the output changes state. See Figures 2-15, 2-17, 2-32 through 2-36 for more information.

3.6 Capacitive Loads

Reasonable capacitive loads (e.g., logic gates) have little impact on propagation delay; see Figure 2-27. The supply current increases with increasing toggle frequency (Figure 2-30), especially with higher capacitive loads.

3.7 Battery Life

In order to maximize battery life in portable applications, use large resistors and small capacitive loads. Also, avoid toggling the output more than necessary, and do not use chip select (\overline{CS}) to conserve power for short periods of time; capacitive loads will draw additional power at start-up.

3.8 Layout Considerations

Good PC board layout techniques will help you achieve the performance shown in the specs and Typical Performance Curves. It will also help you minimize EMC (Electro-Magnetic Compatibility) issues.

3.8.1 SURFACE LEAKAGE

In applications where low input bias current is critical, PC board surface leakage effects and signal coupling from trace to trace need to be considered.

Surface leakage is caused by a difference in voltage between traces, combined with high humidity, dust or other contamination on the board. Under low humidity conditions, a typical resistance between nearby traces is $10^{12}\Omega$. A 5V difference would cause 5 pA of current to flow; this is greater than the input current of the family at 25°C (1 pA, typ).

The simplest technique to reduce surface leakage is using a guard ring around sensitive pins (or traces). The guard ring is biased at the same voltage as the sensitive pin or trace; Figure 3-5 shows an example of a typical layout.

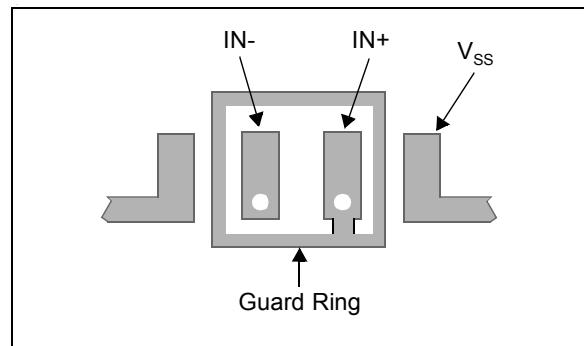

FIGURE 3-5: Example of guard ring layout.

Circuit schematics for different guard ring implementations are shown in Figure 3-6. Figure 3-6A biases the guard ring to the input common mode voltage. Figure 3-6B biases the guard ring to a reference voltage (V_{REF} , which can be ground). Place the guard ring on the node that is the most constant.

MCP6546/7/8/9

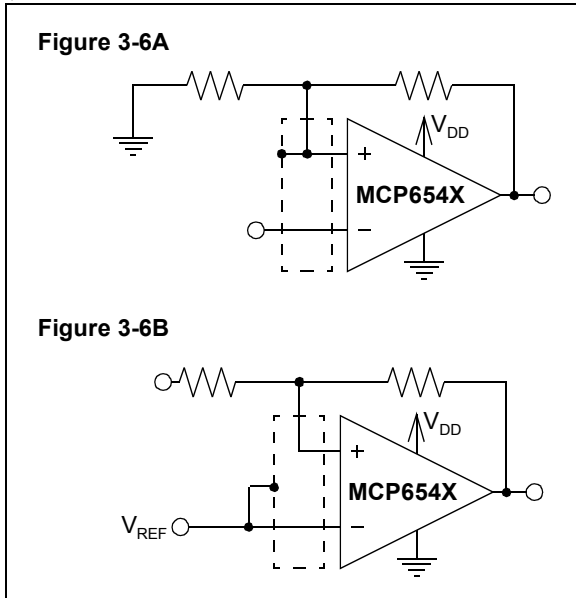

FIGURE 3-6: Two possible guard ring connection strategies to reduce surface leakage effects.

3.8.2 COMPONENT PLACEMENT

Separate digital from analog, and low speed from high speed. This helps prevent crosstalk.

Keep sensitive traces short and straight. Separate them from interfering components and traces. This is especially important for high frequency (low rise time) signals.

Use a 0.1 μF supply bypass capacitor within 0.1" (2.5 mm) of the V_{DD} pin. It must connect directly to the ground plane.

3.8.3 SIGNAL COUPLING

The input pins of the family of op amps are high impedance, which allows noise injection. This noise can be capacitively or magnetically coupled. In either case, using a ground plane helps reduce noise injection.

When noise is coupled capacitively, ground plane reduces the coupling capacitance, and provides shunt capacitance to ground for high frequency signals; Figure 3-7 shows the equivalent circuit. The coupled current, I_M , produces a lower voltage ($V_{TRACE 2}$) on the victim trace when the trace to ground plane capacitance (C_{SH2}) is large, and the terminating resistor (R_{T2}) is small. Increasing the distance between traces, and using wider traces, also helps.

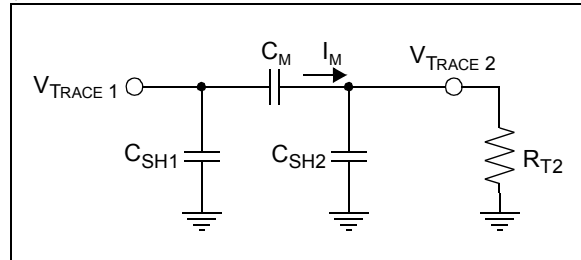

FIGURE 3-7: Equivalent circuit for capacitive coupling between traces on a PC board (with ground plane).

When noise is coupled magnetically, ground plane reduces the mutual inductance between traces. This occurs because the ground return current at high frequencies will follow a path directly beneath the signal trace. Increasing the separation between traces makes a significant difference. Changing the direction of one of the traces can also reduce magnetic coupling.

If these techniques are not enough, it may help to place guard traces next to the victim trace. They should be on both sides of the victim trace, and as close as possible. Connect the guard traces to ground plane at both ends, and in the middle for long traces.

3.9 Typical Applications

3.9.1 PRECISE COMPARATOR

Some applications require higher DC precision. An easy way to solve this problem is to gain up the input signal before it reaches the comparator. Figure 3-8 shows an example of this approach.

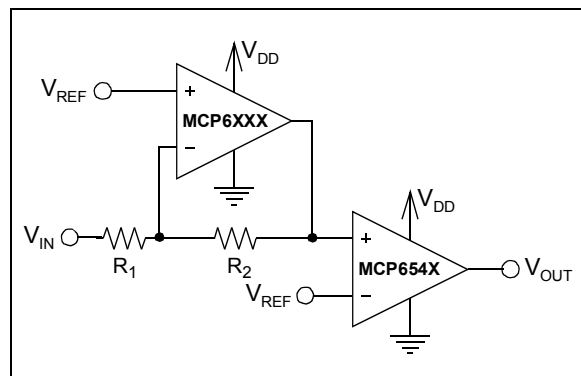

FIGURE 3-8: Precise Inverting comparator.

3.9.2 WINDOWED COMPARATOR

Figure 3-9 shows one approach to designing a windowed comparator. The wired-OR connection produces a high output (logic 1) when the input voltage is between V_{RB} and V_{RT} (where $V_{RT} > V_{RB}$).

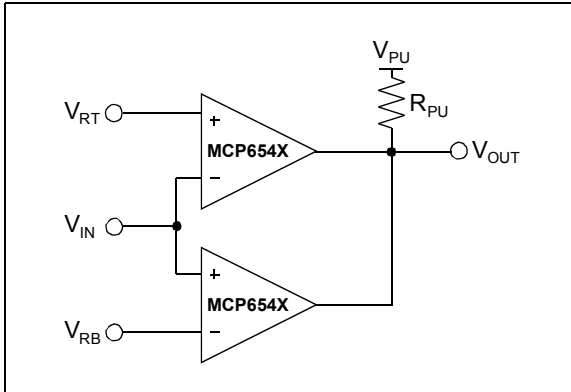

FIGURE 3-9: Windowed comparator.

MCP6546/7/8/9

4.0 PACKAGING INFORMATION

4.1 Package Marking Information

8-Lead PDIP (300 mil)

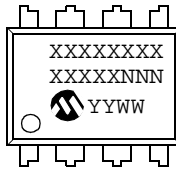

Example:

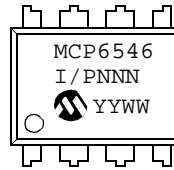

8-Lead SOIC (150 mil)

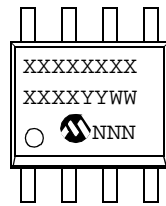

Example:

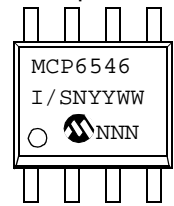

8-Lead MSOP

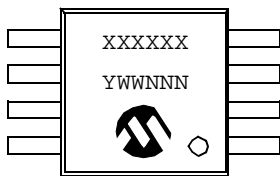

Example:

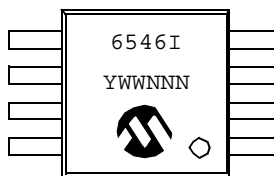

Legend:	XX...X	Customer specific information*
	YY	Year code (last 2 digits of calendar year)
	WW	Week code (week of January 1 is week '01')
	NNN	Alphanumeric traceability code

Note:	In the event the full Microchip part number cannot be marked on one line, it will be carried over to the next line thus limiting the number of available characters for customer specific information.
--------------	--

* Standard marking consists of Microchip part number, year code, week code, traceability code (facility code, mask rev#, and assembly code). For marking beyond this, certain price adders apply. Please check with your Microchip Sales Office.

Package Marking Information (Continued)

14-Lead PDIP (300 mil) (MCP6549)

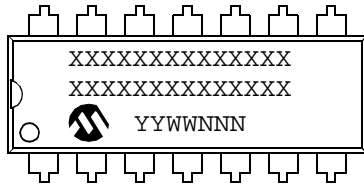

Example:

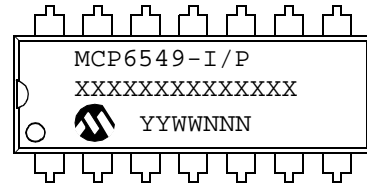

14-Lead SOIC (150 mil) (MCP6549)

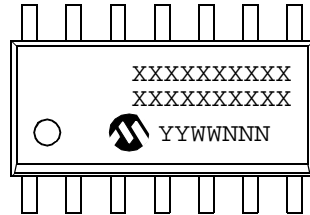

Example:

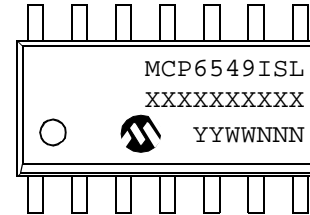

14-Lead TSSOP (MCP6549)

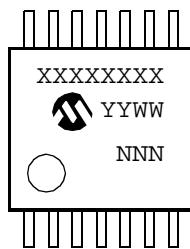

Example:

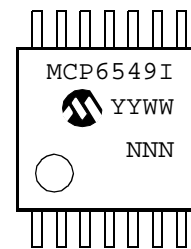

Legend:	XX...X	Customer specific information*
	YY	Year code (last 2 digits of calendar year)
	WW	Week code (week of January 1 is week '01')
	NNN	Alphanumeric traceability code
Note:	In the event the full Microchip part number cannot be marked on one line, it will be carried over to the next line thus limiting the number of available characters for customer specific information.	

* Standard marking consists of Microchip part number, year code, week code, traceability code (facility code, mask rev#, and assembly code). For marking beyond this, certain price adders apply. Please check with your Microchip Sales Office.

MCP6546/7/8/9

8-Lead Plastic Dual In-line (P) – 300 mil (PDIP)

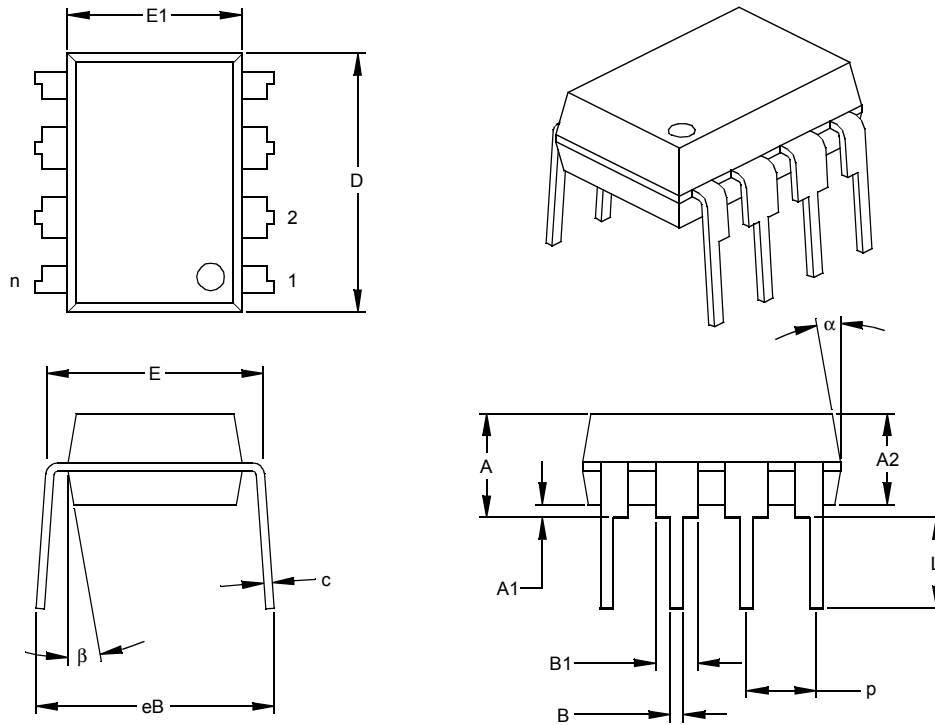

Dimension Limits	Units	INCHES*			MILLIMETERS		
		MIN	NOM	MAX	MIN	NOM	MAX
Number of Pins	n		8			8	
Pitch	p		.100			2.54	
Top to Seating Plane	A	.140	.155	.170	3.56	3.94	4.32
Molded Package Thickness	A2	.115	.130	.145	2.92	3.30	3.68
Base to Seating Plane	A1	.015			0.38		
Shoulder to Shoulder Width	E	.300	.313	.325	7.62	7.94	8.26
Molded Package Width	E1	.240	.250	.260	6.10	6.35	6.60
Overall Length	D	.360	.373	.385	9.14	9.46	9.78
Tip to Seating Plane	L	.125	.130	.135	3.18	3.30	3.43
Lead Thickness	c	.008	.012	.015	0.20	0.29	0.38
Upper Lead Width	B1	.045	.058	.070	1.14	1.46	1.78
Lower Lead Width	B	.014	.018	.022	0.36	0.46	0.56
Overall Row Spacing	§ eB	.310	.370	.430	7.87	9.40	10.92
Mold Draft Angle Top	α	5	10	15	5	10	15
Mold Draft Angle Bottom	β	5	10	15	5	10	15

* Controlling Parameter

§ Significant Characteristic

Notes:

Dimensions D and E1 do not include mold flash or protrusions. Mold flash or protrusions shall not exceed .010" (0.254mm) per side.

JEDEC Equivalent: MS-001

Drawing No. C04-018

MCP6546/7/8/9

8-Lead Plastic Small Outline (SN) – Narrow, 150 mil (SOIC)

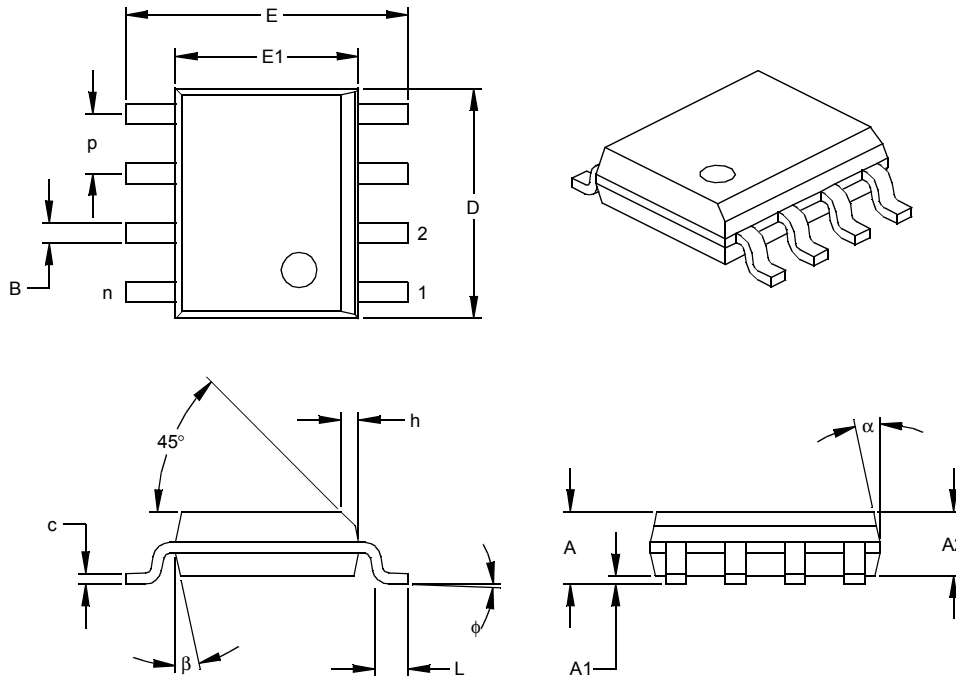

Units		INCHES*			MILLIMETERS		
Dimension	Limits	MIN	NOM	MAX	MIN	NOM	MAX
Number of Pins	n		8			8	
Pitch	p		.050			1.27	
Overall Height	A	.053	.061	.069	1.35	1.55	1.75
Molded Package Thickness	A2	.052	.056	.061	1.32	1.42	1.55
Standoff §	A1	.004	.007	.010	0.10	0.18	0.25
Overall Width	E	.228	.237	.244	5.79	6.02	6.20
Molded Package Width	E1	.146	.154	.157	3.71	3.91	3.99
Overall Length	D	.189	.193	.197	4.80	4.90	5.00
Chamfer Distance	h	.010	.015	.020	0.25	0.38	0.51
Foot Length	L	.019	.025	.030	0.48	0.62	0.76
Foot Angle	φ	0	4	8	0	4	8
Lead Thickness	c	.008	.009	.010	0.20	0.23	0.25
Lead Width	B	.013	.017	.020	0.33	0.42	0.51
Mold Draft Angle Top	α	0	12	15	0	12	15
Mold Draft Angle Bottom	β	0	12	15	0	12	15

* Controlling Parameter
 § Significant Characteristic

Notes:

Dimensions D and E1 do not include mold flash or protrusions. Mold flash or protrusions shall not exceed .010" (0.254mm) per side.

JEDEC Equivalent: MS-012

Drawing No. C04-057

MCP6546/7/8/9

8-Lead Plastic Micro Small Outline Package (MS) (MSOP)

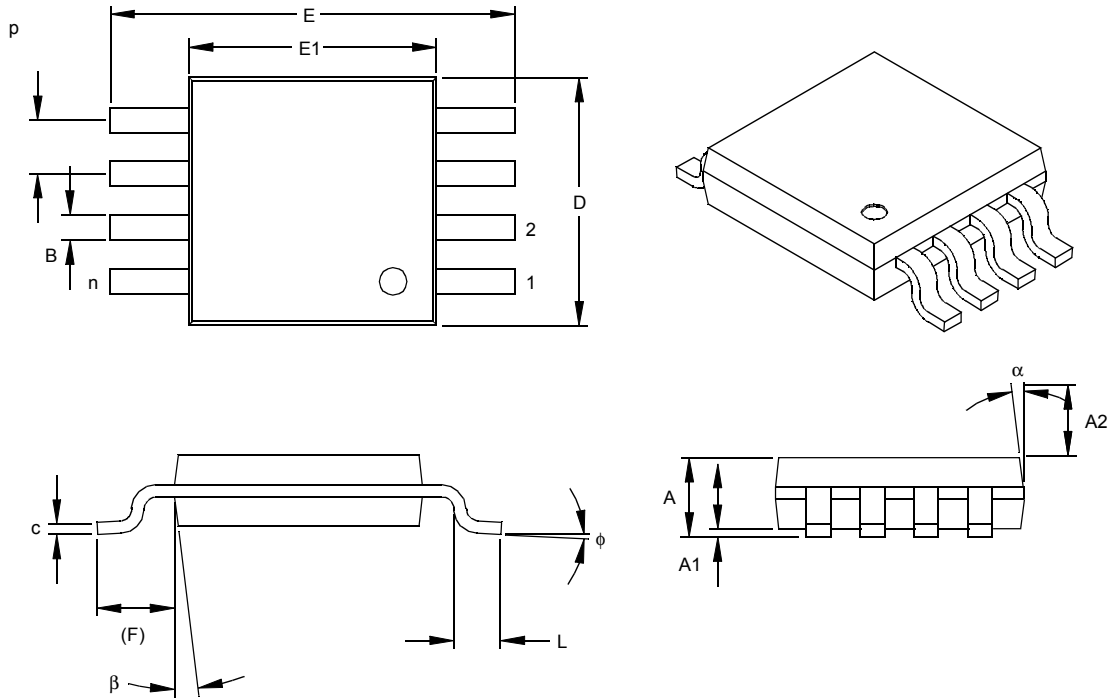

Units		INCHES			MILLIMETERS*		
Dimension Limits		MIN	NOM	MAX	MIN	NOM	MAX
Number of Pins	n		8				8
Pitch	p	.026			0.65		
Overall Height	A			.044			1.18
Molded Package Thickness	A2	.030	.034	.038	0.76	0.86	0.97
Standoff §	A1	.002		.006	0.05		0.15
Overall Width	E	.184	.193	.200	4.67	4.90	5.08
Molded Package Width	E1	.114	.118	.122	2.90	3.00	3.10
Overall Length	D	.114	.118	.122	2.90	3.00	3.10
Foot Length	L	.016	.022	.028	0.40	0.55	0.70
Footprint (Reference)	F	.035	.037	.039	0.90	0.95	1.00
Foot Angle	φ	0		6	0		6
Lead Thickness	c	.004	.006	.008	0.10	0.15	0.20
Lead Width	B	.010	.012	.016	0.25	0.30	0.40
Mold Draft Angle Top	α		7			7	
Mold Draft Angle Bottom	β		7			7	

*Controlling Parameter
 § Significant Characteristic

Notes:

Dimensions D and E1 do not include mold flash or protrusions. Mold flash or protrusions shall not exceed .010" (0.254mm) per side.

Drawing No. C04-111

14-Lead Plastic Dual In-line (P) – 300 mil (PDIP)

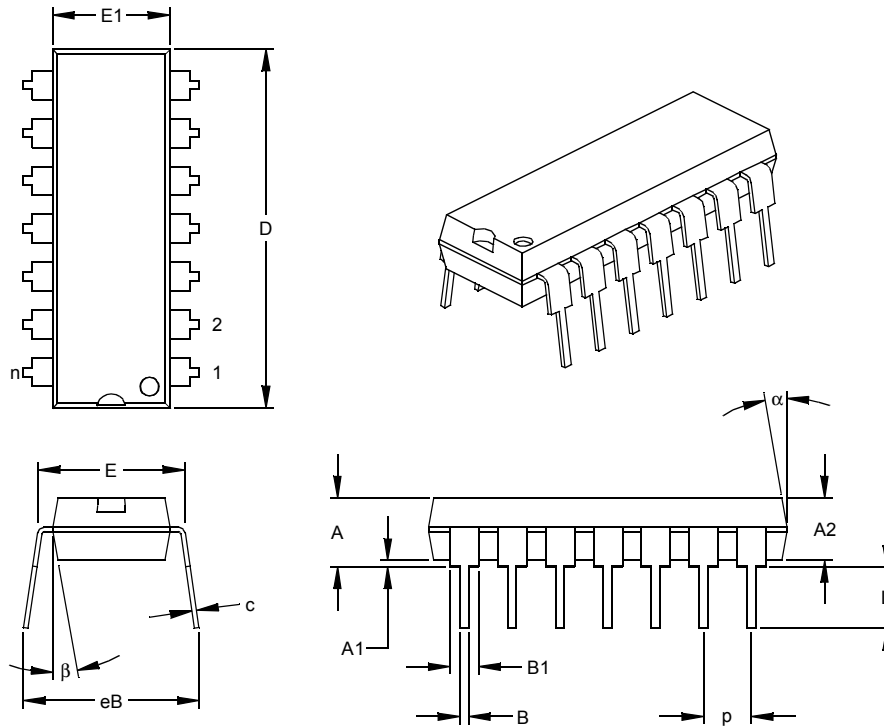

Units		INCHES*			MILLIMETERS		
Dimension Limits		MIN	NOM	MAX	MIN	NOM	MAX
Number of Pins	n		14			14	
Pitch	p		.100			2.54	
Top to Seating Plane	A	.140	.155	.170	3.56	3.94	4.32
Molded Package Thickness	A2	.115	.130	.145	2.92	3.30	3.68
Base to Seating Plane	A1	.015			0.38		
Shoulder to Shoulder Width	E	.300	.313	.325	7.62	7.94	8.26
Molded Package Width	E1	.240	.250	.260	6.10	6.35	6.60
Overall Length	D	.740	.750	.760	18.80	19.05	19.30
Tip to Seating Plane	L	.125	.130	.135	3.18	3.30	3.43
Lead Thickness	c	.008	.012	.015	0.20	0.29	0.38
Upper Lead Width	B1	.045	.058	.070	1.14	1.46	1.78
Lower Lead Width	B	.014	.018	.022	0.36	0.46	0.56
Overall Row Spacing	§ eB	.310	.370	.430	7.87	9.40	10.92
Mold Draft Angle Top	α	5	10	15	5	10	15
Mold Draft Angle Bottom	β	5	10	15	5	10	15

* Controlling Parameter

§ Significant Characteristic

Notes:

Dimensions D and E1 do not include mold flash or protrusions. Mold flash or protrusions shall not exceed .010" (0.254mm) per side.

JEDEC Equivalent: MS-001

Drawing No. C04-005

MCP6546/7/8/9

14-Lead Plastic Small Outline (SL) – Narrow, 150 mil (SOIC)

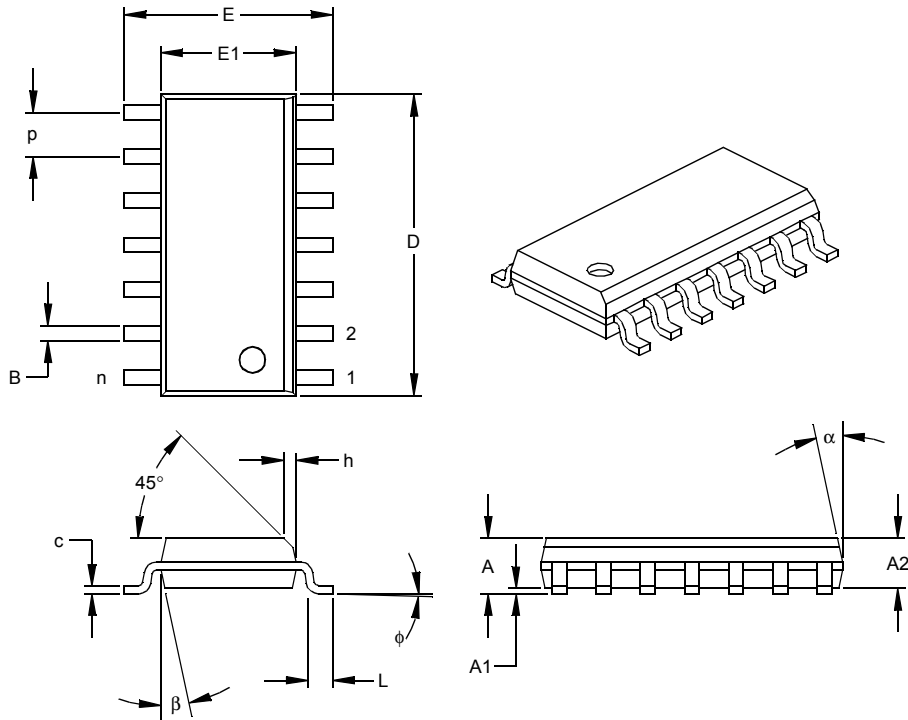

Units		INCHES*			MILLIMETERS		
Dimension Limits		MIN	NOM	MAX	MIN	NOM	MAX
Number of Pins	n		14			14	
Pitch	p		.050			1.27	
Overall Height	A	.053	.061	.069	1.35	1.55	1.75
Molded Package Thickness	A2	.052	.056	.061	1.32	1.42	1.55
Standoff §	A1	.004	.007	.010	0.10	0.18	0.25
Overall Width	E	.228	.236	.244	5.79	5.99	6.20
Molded Package Width	E1	.150	.154	.157	3.81	3.90	3.99
Overall Length	D	.337	.342	.347	8.56	8.69	8.81
Chamfer Distance	h	.010	.015	.020	0.25	0.38	0.51
Foot Length	L	.016	.033	.050	0.41	0.84	1.27
Foot Angle	φ	0	4	8	0	4	8
Lead Thickness	c	.008	.009	.010	0.20	0.23	0.25
Lead Width	B	.014	.017	.020	0.36	0.42	0.51
Mold Draft Angle Top	α	0	12	15	0	12	15
Mold Draft Angle Bottom	β	0	12	15	0	12	15

* Controlling Parameter

§ Significant Characteristic

Notes:

Dimensions D and E1 do not include mold flash or protrusions. Mold flash or protrusions shall not exceed .010" (0.254mm) per side.

JEDEC Equivalent: MS-012

Drawing No. C04-065

14-Lead Plastic Thin Shrink Small Outline (ST) – 4.4 mm (TSSOP)

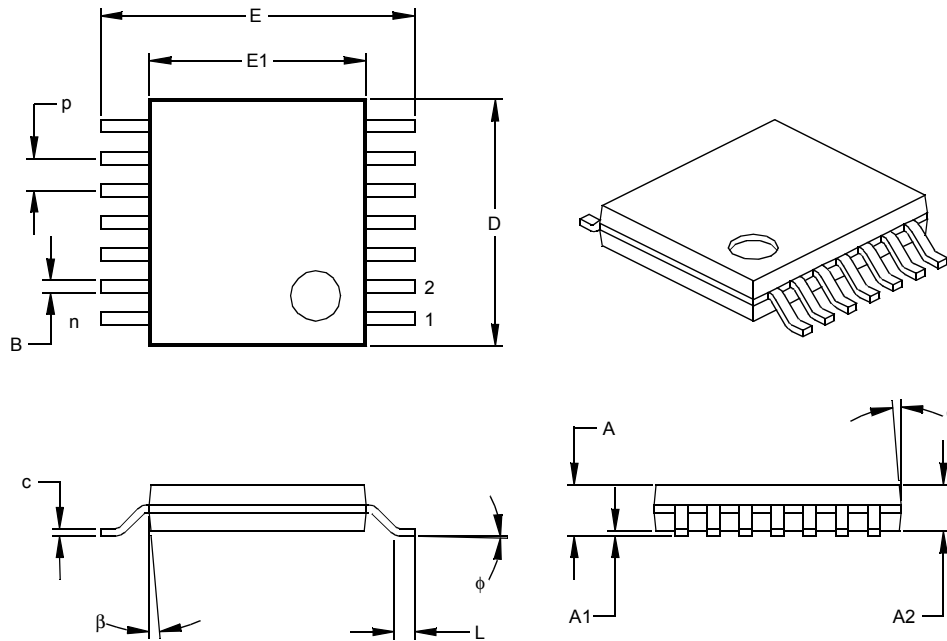

Dimension Limits	Units	INCHES			MILLIMETERS*		
		MIN	NOM	MAX	MIN	NOM	MAX
Number of Pins	n		14			14	
Pitch	p		.026			0.65	
Overall Height	A			.043			1.10
Molded Package Thickness	A2	.033	.035	.037	0.85	0.90	0.95
Standoff §	A1	.002	.004	.006	0.05	0.10	0.15
Overall Width	E	.246	.251	.256	6.25	6.38	6.50
Molded Package Width	E1	.169	.173	.177	4.30	4.40	4.50
Molded Package Length	D	.193	.197	.201	4.90	5.00	5.10
Foot Length	L	.020	.024	.028	0.50	0.60	0.70
Foot Angle	φ	0	4	8	0	4	8
Lead Thickness	c	.004	.006	.008	0.09	0.15	0.20
Lead Width	B1	.007	.010	.012	0.19	0.25	0.30
Mold Draft Angle Top	α	0	5	10	0	5	10
Mold Draft Angle Bottom	β	0	5	10	0	5	10

* Controlling Parameter

§ Significant Characteristic

Notes:

Dimensions D and E1 do not include mold flash or protrusions. Mold flash or protrusions shall not exceed .005" (0.127mm) per side.

JEDEC Equivalent: MO-153

Drawing No. C04-087

MCP6546/7/8/9

NOTES:

ON-LINE SUPPORT

Microchip provides on-line support on the Microchip World Wide Web (WWW) site.

The web site is used by Microchip as a means to make files and information easily available to customers. To view the site, the user must have access to the Internet and a web browser, such as Netscape or Microsoft Explorer. Files are also available for FTP download from our FTP site.

Connecting to the Microchip Internet Web Site

The Microchip web site is available by using your favorite Internet browser to attach to:

www.microchip.com

The file transfer site is available by using an FTP service to connect to:

<ftp://ftp.microchip.com>

The web site and file transfer site provide a variety of services. Users may download files for the latest Development Tools, Data Sheets, Application Notes, User's Guides, Articles and Sample Programs. A variety of Microchip specific business information is also available, including listings of Microchip sales offices, distributors and factory representatives. Other data available for consideration is:

- Latest Microchip Press Releases
- Technical Support Section with Frequently Asked Questions
- Design Tips
- Device Errata
- Job Postings
- Microchip Consultant Program Member Listing
- Links to other useful web sites related to Microchip Products
- Conferences for products, Development Systems, technical information and more
- Listing of seminars and events

Systems Information and Upgrade Hot Line

The Systems Information and Upgrade Line provides system users a listing of the latest versions of all of Microchip's development systems software products. Plus, this line provides information on how customers can receive any currently available upgrade kits. The Hot Line Numbers are:

1-800-755-2345 for U.S. and most of Canada, and
1-480-792-7302 for the rest of the world.

013001

MCP6546/7/8/9

READER RESPONSE

It is our intention to provide you with the best documentation possible to ensure successful use of your Microchip product. If you wish to provide your comments on organization, clarity, subject matter, and ways in which our documentation can better serve you, please FAX your comments to the Technical Publications Manager at (480) 792-4150.

Please list the following information, and use this outline to provide us with your comments about this Data Sheet.

To: Technical Publications Manager Total Pages Sent
RE: Reader Response
From: Name _____
Company _____
Address _____
City / State / ZIP / Country _____
Telephone: (_____) _____ - _____ FAX: (_____) _____ - _____

Application (optional):

Would you like a reply? ___Y ___N

Device: **MCP6546/7/8/9** Literature Number: **DS21714A**

Questions:

1. What are the best features of this document?

2. How does this document meet your hardware and software development needs?

3. Do you find the organization of this data sheet easy to follow? If not, why?

4. What additions to the data sheet do you think would enhance the structure and subject?

5. What deletions from the data sheet could be made without affecting the overall usefulness?

6. Is there any incorrect or misleading information (what and where)?

7. How would you improve this document?

8. How would you improve our software, systems, and silicon products?

PRODUCT IDENTIFICATION SYSTEM

To order or obtain information, e.g., on pricing or delivery, refer to the factory or the listed sales office.

<u>PART NO.</u>	<u>-X</u>	<u>/XX</u>
Device	Temperature Range	Package
Device:	MCP6546: Single Comparator MCP6546T: Single Comparator (Tape and Reel for SOIC and MSOP)	
	MCP6547: Dual Comparator MCP6547T: Dual Comparator (Tape and Reel for SOIC and MSOP)	
	MCP6548: Single Comparator with <u>CS</u> MCP6548T: Single Comparator with <u>CS</u> (Tape and Reel for SOIC and MSOP)	
	MCP6549: Quad Comparator MCP6549T: Quad Comparator (Tape and Reel for SOIC and TSSOP)	
Temperature Range:	I = -40°C to +85°C	
Package:	MS = Plastic MSOP, 8-lead P = Plastic DIP (300 mil Body), 8-lead, 14-lead SN = Plastic SOIC (150 mil Body), 8-lead SL = Plastic SOIC (150 mil Body), 14-lead (MCP6549) ST = Plastic TSSOP (4.4mm Body), 14-lead (MCP6549)	

Examples:

- MCP6546-I/P: Industrial temperature, PDIP package.
- MCP6547T-I/MS: Tape and Reel, Industrial temperature, MSOP package.
- MCP6548-I/SN: Industrial temperature, SOIC package.
- MCP6549-I/ST: Industrial temperature, TSSOP package.
- MCP6549T-I/SL: Tape and Reel, Industrial temperature, SOIC package.

Sales and Support

Data Sheets

Products supported by a preliminary Data Sheet may have an errata sheet describing minor operational differences and recommended workarounds. To determine if an errata sheet exists for a particular device, please contact one of the following:

- Your local Microchip sales office
- The Microchip Corporate Literature Center U.S. FAX: (480) 792-7277
- The Microchip Worldwide Site (www.microchip.com)

Please specify which device, revision of silicon and Data Sheet (include Literature #) you are using.

New Customer Notification System

Register on our web site (www.microchip.com/cn) to receive the most current information on our products.

MCP6546/7/8/9

NOTES:

Information contained in this publication regarding device applications and the like is intended through suggestion only and may be superseded by updates. It is your responsibility to ensure that your application meets with your specifications. No representation or warranty is given and no liability is assumed by Microchip Technology Incorporated with respect to the accuracy or use of such information, or infringement of patents or other intellectual property rights arising from such use or otherwise. Use of Microchip's products as critical components in life support systems is not authorized except with express written approval by Microchip. No licenses are conveyed, implicitly or otherwise, under any intellectual property rights.

Trademarks

The Microchip name and logo, the Microchip logo, FilterLab, KEELOQ, microID, MPLAB, PIC, PICmicro, PICMASTER, PIC-START, PRO MATE, SEEVAL and The Embedded Control Solutions Company are registered trademarks of Microchip Technology Incorporated in the U.S.A. and other countries.

dsPIC, ECONOMONITOR, FanSense, FlexROM, fuzzyLAB, In-Circuit Serial Programming, ICSP, ICEPIC, microPort, Migratable Memory, MPASM, MPLIB, MPLINK, MPSIM, MXDEV, PICC, PICDEM, PICDEM.net, rfPIC, Select Mode and Total Endurance are trademarks of Microchip Technology Incorporated in the U.S.A.

Serialized Quick Turn Programming (SQTP) is a service mark of Microchip Technology Incorporated in the U.S.A.

All other trademarks mentioned herein are property of their respective companies.

© 2002, Microchip Technology Incorporated, Printed in the U.S.A., All Rights Reserved.

 Printed on recycled paper.

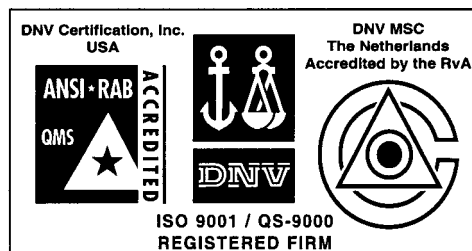

Microchip received QS-9000 quality system certification for its worldwide headquarters, design and wafer fabrication facilities in Chandler and Tempe, Arizona in July 1999. The Company's quality system processes and procedures are QS-9000 compliant for its PICmicro® 8-bit MCUs, KEELOQ® code hopping devices, Serial EEPROMs and microperipheral products. In addition, Microchip's quality system for the design and manufacture of development systems is ISO 9001 certified.



MICROCHIP

WORLDWIDE SALES AND SERVICE

AMERICAS

Corporate Office

2355 West Chandler Blvd.
Chandler, AZ 85224-6199
Tel: 480-792-7200 Fax: 480-792-7277
Technical Support: 480-792-7627
Web Address: <http://www.microchip.com>

Rocky Mountain

2355 West Chandler Blvd.
Chandler, AZ 85224-6199
Tel: 480-692-7966 Fax: 480-792-7456

Atlanta

500 Sugar Mill Road, Suite 200B
Atlanta, GA 30350
Tel: 770-640-0034 Fax: 770-640-0307

Boston

2 Lan Drive, Suite 120
Westford, MA 01886
Tel: 978-692-3848 Fax: 978-692-3821

Chicago

333 Pierce Road, Suite 180
Itasca, IL 60143
Tel: 630-285-0071 Fax: 630-285-0075

Dallas

4570 Westgrove Drive, Suite 160
Addison, TX 75001
Tel: 972-818-7423 Fax: 972-818-2924

Detroit

Tri-Atria Office Building
32255 Northwestern Highway, Suite 190
Farmington Hills, MI 48334
Tel: 248-538-2250 Fax: 248-538-2260

Kokomo

2767 S. Albright Road
Kokomo, Indiana 46902
Tel: 765-864-8360 Fax: 765-864-8387

Los Angeles

18201 Von Karman, Suite 1090
Irvine, CA 92612
Tel: 949-263-1888 Fax: 949-263-1338

New York

150 Motor Parkway, Suite 202
Hauppauge, NY 11788
Tel: 631-273-5305 Fax: 631-273-5335

San Jose

Microchip Technology Inc.
2107 North First Street, Suite 590
San Jose, CA 95131
Tel: 408-436-7950 Fax: 408-436-7955

Toronto

6285 Northam Drive, Suite 108
Mississauga, Ontario L4V 1X5, Canada
Tel: 905-673-0699 Fax: 905-673-6509

ASIA/PACIFIC

Australia

Microchip Technology Australia Pty Ltd
Suite 22, 41 Rawson Street
Epping 2121, NSW
Australia
Tel: 61-2-9868-6733 Fax: 61-2-9868-6755

China - Beijing

Microchip Technology Consulting (Shanghai)
Co., Ltd., Beijing Liaison Office
Unit 915
Bei Hai Wan Tai Bldg.
No. 6 Chaoyangmen Beidajie
Beijing, 100027, No. China
Tel: 86-10-85282100 Fax: 86-10-85282104

China - Chengdu

Microchip Technology Consulting (Shanghai)
Co., Ltd., Chengdu Liaison Office
Rm. 2401, 24th Floor,
Ming Xing Financial Tower
No. 88 TIDU Street
Chengdu 610016, China
Tel: 86-28-6766200 Fax: 86-28-6766599

China - Fuzhou

Microchip Technology Consulting (Shanghai)
Co., Ltd., Fuzhou Liaison Office
Unit 28F, World Trade Plaza
No. 71 Wusi Road
Fuzhou 350001, China
Tel: 86-591-7503506 Fax: 86-591-7503521

China - Shanghai

Microchip Technology Consulting (Shanghai)
Co., Ltd.
Room 701, Bldg. B
Far East International Plaza
No. 317 Xian Xia Road
Shanghai, 200051
Tel: 86-21-6275-5700 Fax: 86-21-6275-5060

China - Shenzhen

Microchip Technology Consulting (Shanghai)
Co., Ltd., Shenzhen Liaison Office
Rm. 1315, 13/F, Shenzhen Kerry Centre,
Renminnan Lu
Shenzhen 518001, China
Tel: 86-755-2350361 Fax: 86-755-2366086

Hong Kong

Microchip Technology Hongkong Ltd.
Unit 901-6, Tower 2, Metroplaza
223 Hing Fong Road
Kwai Fong, N.T., Hong Kong
Tel: 852-2401-1200 Fax: 852-2401-3431

India

Microchip Technology Inc.
India Liaison Office
Divyasree Chambers
1 Floor, Wing A (A3/A4)
No. 11, O'Shaughnessey Road
Bangalore, 560 025, India
Tel: 91-80-2290061 Fax: 91-80-2290062

Japan

Microchip Technology Japan K.K.
Benex S-1 6F
3-18-20, Shinyokohama
Kohoku-Ku, Yokohama-shi
Kanagawa, 222-0033, Japan
Tel: 81-45-471-6166 Fax: 81-45-471-6122

Korea

Microchip Technology Korea
168-1, Youngbo Bldg. 3 Floor
Samsung-Dong, Kangnam-Ku
Seoul, Korea 135-882
Tel: 82-2-554-7200 Fax: 82-2-558-5934

Singapore

Microchip Technology Singapore Pte Ltd.
200 Middle Road
#07-02 Prime Centre
Singapore, 188980
Tel: 65-6334-8870 Fax: 65-6334-8850

Taiwan

Microchip Technology Taiwan
11F-3, No. 207
Tung Hua North Road
Taipei, 105, Taiwan
Tel: 886-2-2717-7175 Fax: 886-2-2545-0139

EUROPE

Denmark

Microchip Technology Nordic ApS
Regus Business Centre
Lautrup høj 1-3
Ballerup DK-2750 Denmark
Tel: 45 4420 9895 Fax: 45 4420 9910

France

Microchip Technology SARL
Parc d'Activite du Moulin de Massy
43 Rue du Saule Trapu
Batiment A - 1er Etage
91300 Massy, France
Tel: 33-1-69-53-63-20 Fax: 33-1-69-30-90-79

Germany

Microchip Technology GmbH
Gustav-Heinemann Ring 125
D-81739 Munich, Germany
Tel: 49-89-627-144 0 Fax: 49-89-627-144-44

Italy

Microchip Technology SRL
Centro Direzionale Colleoni
Palazzo Taurus 1 V. Le Colleoni 1
20041 Agrate Brianza
Milan, Italy
Tel: 39-039-65791-1 Fax: 39-039-6899883

United Kingdom

Arizona Microchip Technology Ltd.
505 Eskdale Road
Winnersh Triangle
Wokingham
Berkshire, England RG41 5TU
Tel: 44 118 921 5869 Fax: 44-118 921-5820

03/01/02

