



±15kV ESD-Protected, +5V RS-232 Transceivers

General Description

The MAX202E/MAX203E/MAX232E/MAX211E/MAX213E/MAX241E line drivers/receivers are designed for RS-232 and V.28 communications in harsh environments. Each transmitter output and receiver input is protected against ±15kV electrostatic discharge (ESD) shocks, without latchup. The MAX211E/MAX213E/MAX241E comprise four line drivers and five receivers; they also feature a shutdown mode and a receiver-enable input. The MAX202E, MAX203E, and MAX232E have two drivers and two receivers. The drivers and receivers for all five devices meet all EIA/TIA-232E and CCITT V.28 specifications at data rates up to 120kbps when loaded in accordance with the EIA/TIA-232E specification.

The MAX211E/MAX213E/MAX241E are available in a 28-pin wide SO package, as well as a 28-pin SSOP package that requires 60% less board space. The MAX202E and MAX232E come in 16-pin narrow SO, wide SO, DIP, and CERDIP packages, as well as a 20-pin ceramic LCC package. The MAX203E comes in 20-pin DIP and wide SO packages, and requires no external charge-pump capacitors. The MAX232E and MAX241E operate with four 1μF capacitors, while the MAX202E/MAX211E/MAX213E operate with four 0.1μF capacitors, further reducing cost and board space.

Applications

Notebook, Subnotebook, and Palmtop Computers
Battery-Powered Equipment
Hand-Held Equipment

Selection Table

Part Number	No. of RS-232 Drivers	No. of RS-232 Receivers	Receiver Three-State Output Shutdown	External Capacitor Value	ESD Protection (kV)
MAX202E	2	2	No	No	0.1 ±15
MAX203E	2	2	No	No	— ±15
MAX211E	4	5	Yes	Yes	0.1 ±15
MAX213E	4	5	Yes*	Yes	0.1 ±15
MAX232E	2	2	No	No	1.0 ±15
MAX241E	4	5	Yes	Yes	1.0 ±15

*Two receivers active

LapLink is a registered trademark of Traveling Software, Inc.

Features

Better than Bipolar!

- ♦ **ESD Protection for RS-232 I/O Pins:**
 - ±15kV—Human Body Model
 - ±8kV—IEC801-2, Contact Discharge
 - ±15kV—IEC801-2, Air-Gap Discharge
- ♦ **Latchup Free (unlike bipolar equivalents)**
- ♦ **2 Drivers, 2 Receivers (MAX202E/203E/232E)**
4 Drivers, 5 Receivers (MAX211E/213E/241E)
- ♦ **Guaranteed 120kbps Data Rate—LapLink™ Compatible**
- ♦ **Guaranteed 3V/μs Min Slew Rate**
- ♦ **Operate from Single +5V Power Supply**

Ordering Information

PART	TEMP. RANGE	PIN-PACKAGE
MAX202ECPE	0°C to +70°C	16 Plastic DIP
MAX202ECSE	0°C to +70°C	16 Narrow SO
MAX202ECWE	0°C to +70°C	16 Wide SO
MAX202EC/D	0°C to +70°C	Dice*
MAX202EEPE	-40°C to +85°C	16 Plastic DIP
MAX202EESE	-40°C to +85°C	16 Narrow SO
MAX202EEWE	-40°C to +85°C	16 Wide SO

Ordering Information continued at end of data sheet.

*Dice are specified at $T_A = +25^\circ\text{C}$.

Pin Configurations

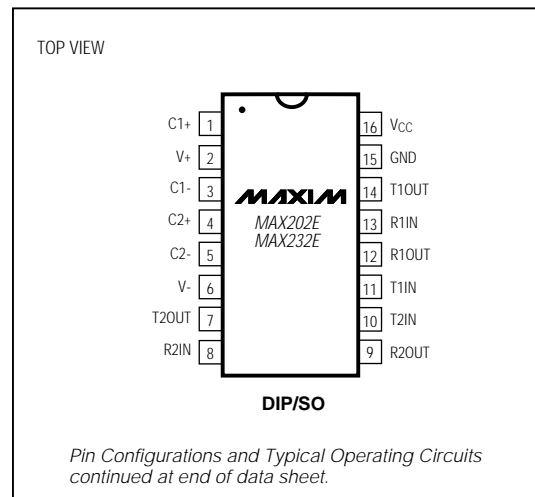

MAX202E/MAX203E/MAX211E/MAX213E/MAX213E/MAX232E/MAX241E



Maxim Integrated Products 1

Call toll free 1-800-998-8800 for free samples or literature.

±15kV ESD-Protected, +5V RS-232 Transceivers

ABSOLUTE MAXIMUM RATINGS

V _{CC}	-0.3V to +6V
V ₊	(V _{CC} - 0.3V) to +14V
V ₋	-14V to +0.3V
Input Voltages	
T _{IN}	-0.3V to (V _{CC} + 0.3V)
R _{IN}	±30V
Output Voltages	
T _{OUT}	(V ₋ - 0.3V) to (V ₊ + 0.3V)
R _{OUT}	-0.3V to (V _{CC} + 0.3V)
Short-Circuit Duration, T _{OUT}	Continuous
Power Dissipation (T _A = +70°C)	
16-Pin Plastic DIP (derate 10.53mW/°C above +70°C)842mW
16-Pin Narrow SO (derate 8.70mW/°C above +70°C)696mW
16-Pin Wide SO (derate 9.52mW/°C above +70°C)762mW
16-Pin CERDIP (derate 10.00mW/°C above +70°C)800mW

20-Pin Plastic DIP (derate 11.11mW/°C above +70°C)889mW	
20-Pin Wide SO (derate 10.00mW/°C above +70°C)800mW	
20-Pin LCC (derate 9.09mW/°C above +70°C)727mW	
28-Pin Wide SO (derate 12.50mW/°C above +70°C)	1.000mW	
28-Pin SSOP (derate 9.52mW/°C above +70°C)762mW	
Operating Temperature Ranges		
MAX2_EC_	0°C to +70°C	
MAX2_EE_	-40°C to +85°C	
MAX232EM_	-55°C to +125°C	
Storage Temperature Range		-65°C to +165°C
Lead Temperature (soldering, 10sec)		+300°C

Stresses beyond those listed under "Absolute Maximum Ratings" may cause permanent damage to the device. These are stress ratings only, and functional operation of the device at these or any other conditions beyond those indicated in the operational sections of the specifications is not implied. Exposure to absolute maximum rating conditions for extended periods may affect device reliability.

ELECTRICAL CHARACTERISTICS

(V_{CC} = 4.5V to 5.5V, C1-C4 = 0.1µF for MAX202E/MAX211E/MAX213E, C1-C4 = 1.0µF for MAX232E/MAX241E, T_A = T_{MIN} to T_{MAX}, unless otherwise noted. Typical values are at T_A = +25°C.)

PARAMETER	SYMBOL	CONDITIONS	MIN	TYP	MAX	UNITS	
DC CHARACTERISTICS							
Operating Voltage Range	V _{CC}		4.5		5.5	V	
V _{CC} Supply Current	I _{CC}	No load, T _A = +25°C	MAX202E/MAX203E		8	15	mA
			MAX211E/MAX213E		14	20	
			MAX232E		5	10	
			MAX241E		7	15	
Shutdown Supply Current		T _A = +25°C, Figure 1	MAX211E/MAX241E		1	10	µA
			MAX213E		15	50	
LOGIC							
Input Pull-Up Current		T _{IN} = 0V (MAX211E/MAX213E/MAX241E))		15	200	µA	
Input Leakage Current		T _{IN} = 0V to V _{CC} (MAX202E/MAX203E/MAX232E)			±10	µA	
Input Threshold Low	V _{IL}	T _{IN} ; EN, $\overline{\text{SHDN}}$ (MAX213E) or $\overline{\text{EN}}$, SHDN (MAX211E/MAX241E)			0.8	V	
Input Threshold High	V _{IH}	T _{IN}		2.0		V	
		EN, $\overline{\text{SHDN}}$ (MAX213) or $\overline{\text{EN}}$, SHDN (MAX211E/MAX241E)		2.4			
Output Voltage Low	V _{OL}	R _{OUT} ; I _{OUT} = 3.2mA (MAX202E/MAX203E/MAX232E) or I _{OUT} = 1.6mA (MAX211E/MAX213E/MAX241E)			0.4	V	
Output Voltage High	V _{OH}	R _{OUT} ; I _{OUT} = -1.0mA	3.5	V _{CC} - 0.4		V	
Output Leakage Current		0V ≤ R _{OUT} ≤ V _{CC} , MAX211E/MAX213E/MAX241E outputs disabled		±0.05	±10	µA	

±15kV ESD-Protected, +5V RS-232 Transceivers

ELECTRICAL CHARACTERISTICS

(V_{CC} = 4.5V to 5.5V, C1–C4 = 0.1μF for MAX202E/MAX211E/MAX213E, C1–C4 = 1.0μF for MAX232E/MAX241E, T_A = T_{MIN} to T_{MAX}, unless otherwise noted. Typical values are at T_A = +25°C.)

PARAMETER	SYMBOL	CONDITIONS	MIN	TYP	MAX	UNITS
EIA/TIA-232E RECEIVER INPUTS						
Input Voltage Range			-30		+30	V
Input Threshold Low		T _A = +25°C, V _{CC} = 5V	All parts, normal operation			V
			0.8	1.2		
			0.6	1.5		
Input Threshold High		T _A = +25°C, V _{CC} = 5V	All parts, normal operation			V
			1.7	2.4		
			1.5	2.4		
Input Hysteresis		V _{CC} = 5V, no hysteresis for the MAX211E/MAX213E/MAX241E in shutdown	0.2	0.5	1.0	V
Input Resistance		T _A = +25°C, V _{CC} = 5V	3	5	7	kΩ
EIA/TIA-232E TRANSMITTER OUTPUTS						
Output Voltage Swing		All driver inputs loaded with 3kΩ to ground (Note 1)	±5.0	±9		V
Output Resistance		V _{CC} = V ₊ = V ₋ = 0V, V _{OUT} = ±2V	300			Ω
Output Short-Circuit Current				±10	±60	mA
TIMING CHARACTERISTICS						
Maximum Data Rate		R _L = 3kΩ to 7kΩ, C _L = 50pF to 1000pF, one transmitter switching	120			kbps
Receiver Propagation Delay	t _{PLHR} , t _{PHLR}	C _L = 150pF	All parts, normal operation			μs
			0.5	10		
			4	40		
Receiver Output Enable Time		MAX211E/MAX213E/MAX241E, normal operation, Figure 2		600		ns
Receiver Output Disable Time		MAX211E/MAX213E/MAX241E, normal operation, Figure 2		200		ns
Transmitter Propagation Delay	t _{PLHT} , t _{PHLT}	R _L = 3kΩ, C _L = 2500pF, all transmitters loaded		2		μs
Transition-Region Slew Rate		T _A = +25°C, V _{CC} = 5V, R _L = 3kΩ to 7kΩ, C _L = 50pF to 2500pF, measured from -3V to +3V or +3V to -3V, Figure 3	3	6	30	V/μs
ESD PERFORMANCE; TRANSMITTER OUTPUTS, RECEIVER INPUTS						
ESD-Protection Voltage		Human Body Model		±15		kV
		IEC801-2, Contact Discharge		±8		
		IEC801-2, Air-Gap Discharge		±15		

Note 1: MAX211EE__ and MAX213EE__ tested with V_{CC} = 5V ±5%.

MAX202E/MAX203E/MAX211E/MAX213E/MAX232E/MAX241E

±15kV ESD-Protected, +5V RS-232 Transceivers

Typical Operating Characteristics

(Typical Operating Circuits, $V_{CC} = 5.0V$, $T_A = +25^\circ C$, unless otherwise noted.)

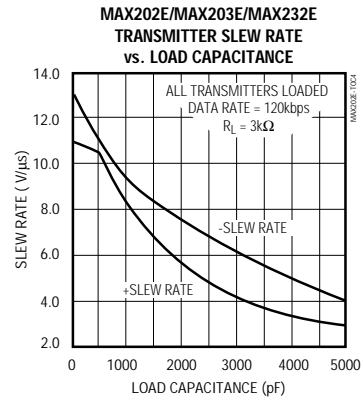
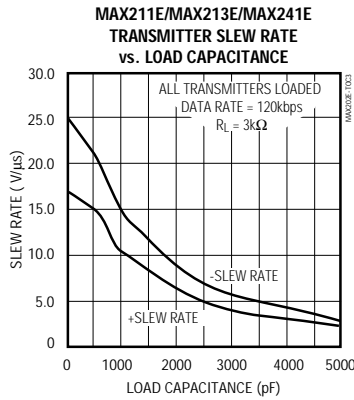
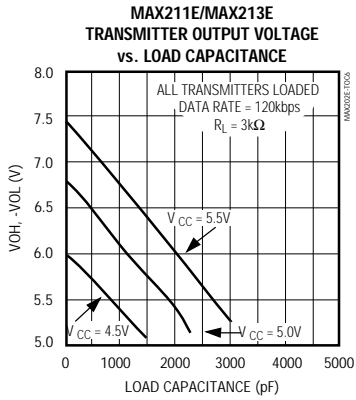
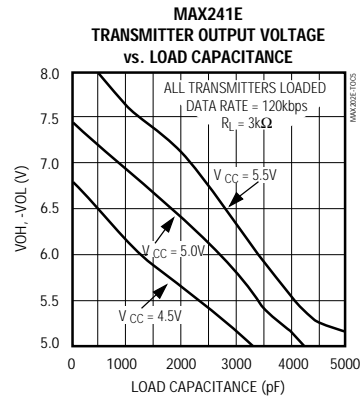
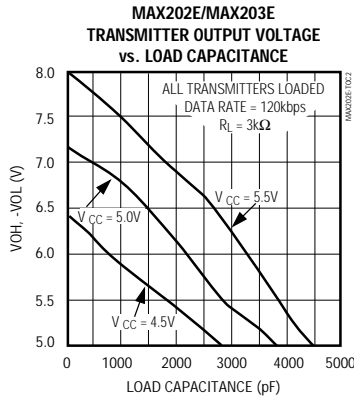
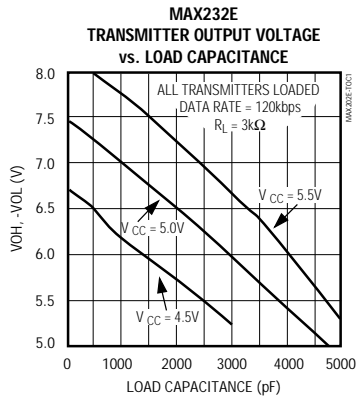

±15kV ESD-Protected, +5V RS-232 Transceivers

Pin Descriptions

MAX202E/MAX232E

PIN		NAME	FUNCTION
DIP/SO	LCC		
1, 3	2, 4	C1+, C1-	Terminals for positive charge-pump capacitor
2	3	V+	+2V _{CC} voltage generated by the charge pump
4, 5	5, 7	C2+, C2-	Terminals for negative charge-pump capacitor
6	8	V-	-2V _{CC} voltage generated by the charge pump
7, 14	9, 18	T_OUT	RS-232 Driver Outputs
8, 13	10, 17	R_IN	RS-232 Receiver Outputs
9, 12	12, 15	R_OUT	RS-232 Receiver Outputs
10, 11	13, 14	T_IN	RS-232 Driver Inputs
15	19	GND	Ground
16	20	V _{CC}	+4.5V to +5.5V Supply Voltage Input
—	1, 6, 11, 16	N.C.	No Connect—not internally connected

MAX203E

PIN		NAME	FUNCTION
DIP	SO		
1, 2	1, 2	T_IN	RS-232 Driver Inputs
3, 20	3, 20	R_OUT	RS-232 Receiver Outputs
4, 19	4, 19	R_IN	RS-232 Receiver Inputs
5, 18	5, 18	T_OUT	RS-232 Transmitter Outputs
6, 9	6, 9	GND	Ground
7	7	V _{CC}	+4.5V to +5.5V Supply Voltage Input
8	13	C1+	Make no connection to this pin.
10, 16	11, 16	C2-	Connect pins together.
12, 17	10, 17	V-	+2V _{CC} voltage generated by the charge pump. Connect pins together.
13	14	C1-	Make no connection to this pin.
14	8	V+	+2V _{CC} voltage generated by the charge pump
11, 15	12, 15	C2+	Connect pins together.

MAX211E/MAX213E/MAX241E

PIN	NAME	FUNCTION
1, 2, 3, 28	T_OUT	RS-232 Driver Outputs
4, 9, 18, 23, 27	R_IN	RS-232 Receiver Inputs
5, 8, 19, 22, 26	R_OUT	TTL/CMOS Receiver Outputs. For the MAX213E, receivers R4 and R5 are active in shutdown mode when EN = 1. For the MAX211E and MAX241E, all receivers are inactive in shutdown.
6, 7, 20, 21	T_IN	TTL/CMOS Driver Inputs. Only the MAX211E, MAX213E, and MAX241E have internal pull-ups to V _{CC} .
10	GND	Ground
11	V _{CC}	+4.5V to +5.5V Supply Voltage
12, 14	C1+, C1-	Terminals for positive charge-pump capacitor
13	V+	+2V _{CC} voltage generated by the charge pump
15, 16	C2+, C2-	Terminals for negative charge-pump capacitor
17	V-	-2V _{CC} voltage generated by the charge pump
24	EN	Receiver Enable—active low (MAX211E, MAX241E)
	EN	Receiver Enable—active high (MAX213E)
25	SHDN	Shutdown Control—active high (MAX211E, MAX241E)
	SHDN	Shutdown Control—active low (MAX213E)

±15kV ESD-Protected, +5V RS-232 Transceivers

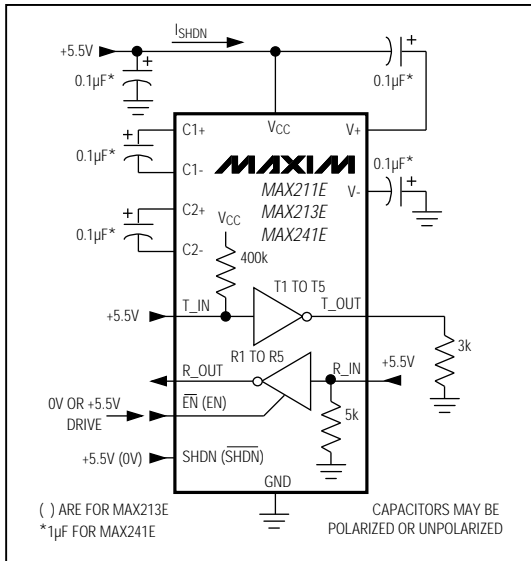

Figure 1. Shutdown-Current Test Circuit (MAX211E/MAX213E/MAX241E)

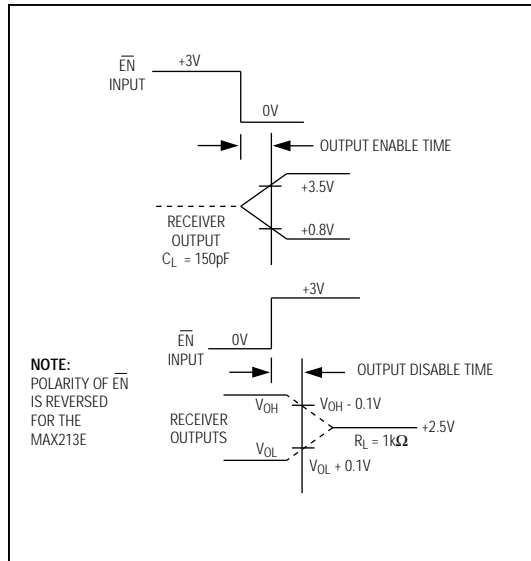

Figure 2. Receiver Output Enable and Disable Timing (MAX211E/MAX213E/MAX241E)

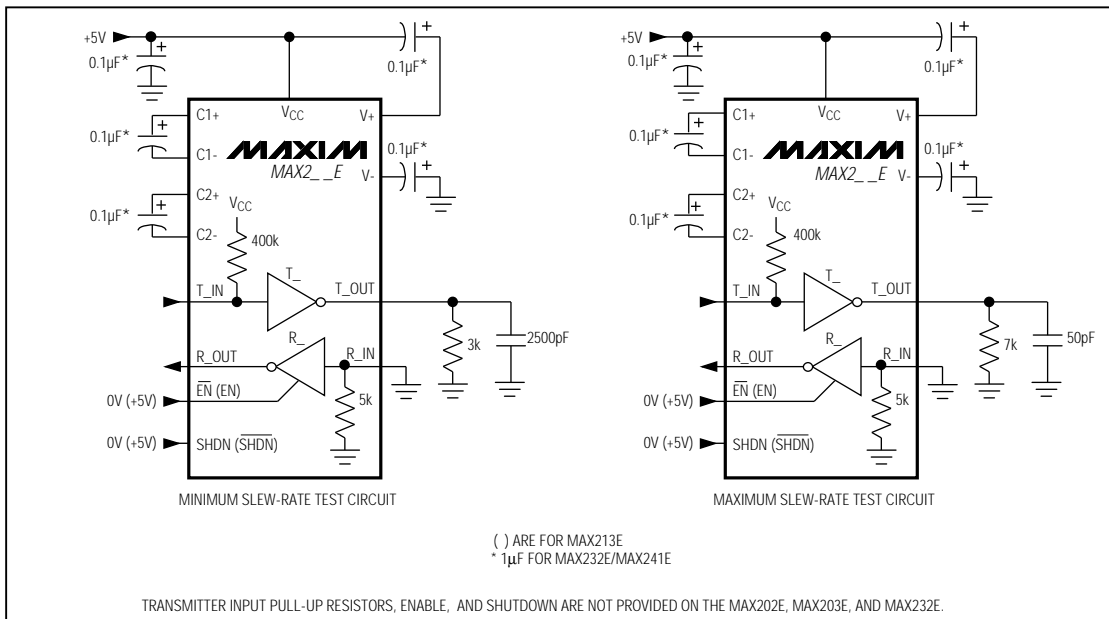

Figure 3. Transition Slew-Rate Circuit

±15kV ESD-Protected, +5V RS-232 Transceivers

Detailed Description

The MAX202E/MAX203E/MAX232E/MAX211E/MAX213E/MAX241E consist of three sections: charge-pump voltage converters, drivers (transmitters), and receivers. These E versions of the MAX202, MAX203, MAX211, MAX213, MAX232, and MAX241 provide extra protection against ESD. They survive ±15kV discharges to the RS-232 inputs and outputs, tested using the Human Body Model. When tested according to IEC801-2, they survive ±8kV contact-discharges and ±15kV air-gap discharges. The rugged MAX202E/MAX203E/MAX211E/MAX213E/MAX232E/MAX241E are intended for use in harsh environments, or applications where the RS-232 connection is frequently changed (such as notebook computers). The standard (non-"E") MAX202, MAX203, MAX211, MAX213, MAX232, and MAX241 are recommended for applications where cost is critical.

+5V to ±10V Dual Charge-Pump Voltage Converter

The +5V to ±10V conversion is performed by dual charge-pump voltage converters (Figure 4). The first charge-pump converter uses capacitor C1 to double the +5V into +10V, storing the +10V on the output filter capacitor, C3. The second uses C2 to invert the +10V into -10V, storing the -10V on the V- output filter capacitor, C4.

In shutdown mode, V+ is internally connected to VCC by a 1kΩ pull-down resistor, and V- is internally connected to ground by a 1kΩ pull-up resistor.

RS-232 Drivers

With VCC = 5V, the typical driver output voltage swing is ±8V when loaded with a nominal 5kΩ RS-232 receiver. The output swing is guaranteed to meet EIA/TIA-232E and V.28 specifications that call for ±5V minimum output levels under worst-case conditions. These include a 3kΩ load, minimum VCC, and maximum operating temperature. The open-circuit output voltage swings from (V+ - 0.6V) to V-.

Input thresholds are both CMOS and TTL compatible. The inputs of unused drivers on the MAX211E, MAX213E, and MAX241E can be left unconnected because 400kΩ pull-up resistors to VCC are included on-chip. Since all drivers invert, the pull-up resistors force the outputs of unused drivers low. The MAX202E, MAX203E, and MAX232E do not have pull-up resistors on the transmitter inputs.

When in low-power shutdown mode, the MAX211E/MAX213E/MAX241E driver outputs are turned off and draw only leakage currents—even if they are back-driven with voltages between 0V and 12V. Below -0.5V in shutdown, the transmitter output is diode-clamped to ground with a 1kΩ series impedance.

RS-232 Receivers

The receivers convert the RS-232 signals to CMOS-logic output levels. The guaranteed 0.8V and 2.4V receiver input thresholds are significantly tighter than the ±3V thresholds required by the EIA/TIA-232E specification. This allows the receiver inputs to respond to TTL/CMOS-logic levels, as well as RS-232 levels.

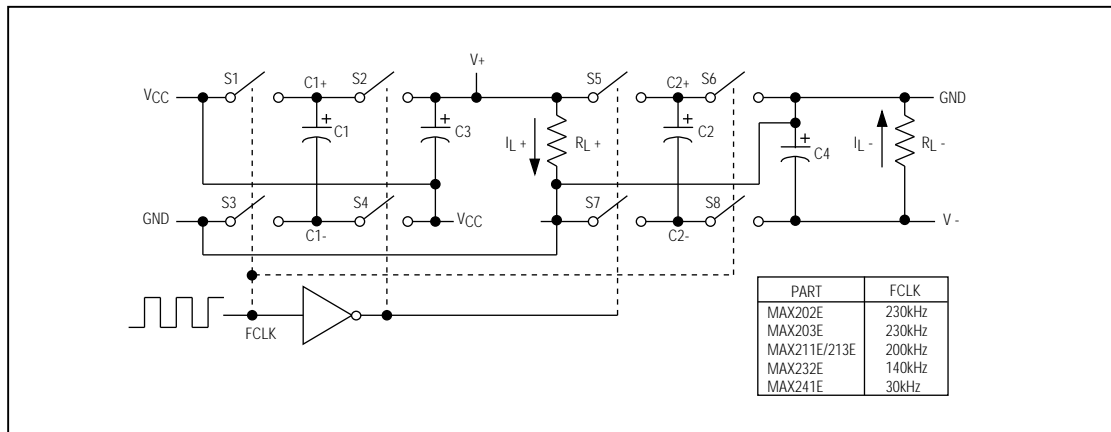

Figure 4. Charge-Pump Diagram

MAX202E/MAX203E/MAX211E/MAX213E/MAX232E/MAX241E

±15kV ESD-Protected, +5V RS-232 Transceivers

The guaranteed 0.8V input low threshold ensures that receivers shorted to ground have a logic 1 output. The 5kΩ input resistance to ground ensures that a receiver with its input left open will also have a logic 1 output.

Receiver inputs have approximately 0.5V hysteresis. This provides clean output transitions, even with slow rise- and fall-time signals with moderate amounts of noise and ringing.

In shutdown, the MAX213E's R4 and R5 receivers have no hysteresis.

Shutdown and Enable Control (MAX211E/MAX213E/MAX241E)

In shutdown mode, the charge pumps are turned off, V+ is pulled down to VCC, V- is pulled to ground, and the transmitter outputs are disabled. This reduces supply current typically to 1μA (15μA for the MAX213E). The time required to exit shutdown is under 1ms, as shown in Figure 5.

Receivers

All MAX213E receivers, except R4 and R5, are put into a high-impedance state in shutdown mode (see Tables 1a and 1b). The MAX213E's R4 and R5 receivers still function in shutdown mode. These two awake-in-shutdown receivers can monitor external activity while maintaining minimal power consumption.

The enable control is used to put the receiver outputs into a high-impedance state, to allow wire-OR connection of two EIA/TIA-232E ports (or ports of different types) at the UART. It has no effect on the RS-232 drivers or the charge pumps.

Note: The enable control pin is active low for the MAX211E and the MAX241E (\overline{EN}), but is active high for the MAX213E (EN). The shutdown control pin is active high for the MAX211E and the MAX241E (SHDN), but is active low for the MAX213E (\overline{SHDN}).

The MAX213E's receiver propagation delay is typically 0.5μs in normal operation. In shutdown mode, propagation delay increases to 4μs for both rising and falling transitions. The MAX213E's receiver inputs have approximately 0.5V hysteresis, except in shutdown, when receivers R4 and R5 have no hysteresis.

When entering shutdown with receivers active, R4 and R5 are not valid until 80μs after SHDN is driven low. When coming out of shutdown, all receiver outputs are invalid until the charge pumps reach nominal values (less than 2ms when using 0.1μF capacitors).

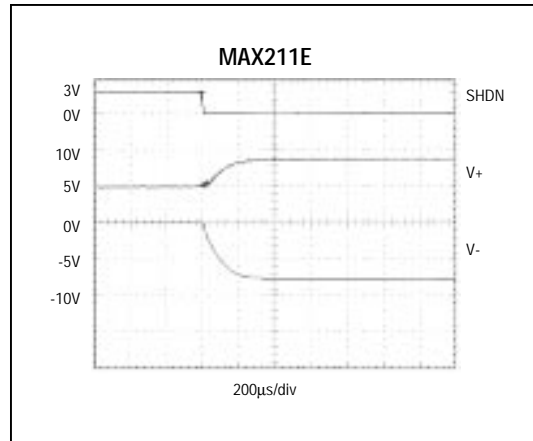

Figure 5. MAX211E V+ and V- when Exiting Shutdown (0.1μF capacitors)

Table 1a. MAX211E/MAX241E Control Pin Configurations

SHDN	EN	OPERATION STATUS	Tx 1-4	Rx 1-5
0	0	Normal Operation	All Active	All Active
0	1	Normal Operation	All Active	All High-Z
1	X	Shutdown	All High-Z	All High-Z

X = Don't Care

Table 1b. MAX213E Control Pin Configurations

SHDN	EN	OPERATION STATUS	Tx 1-4	Rx	
				1-3	4, 5
0	0	Shutdown	All High-Z	High-Z	High-Z
0	1	Shutdown	All High-Z	High-Z	Active*
1	0	Normal Operation	All Active	High-Z	High-Z
1	1	Normal Operation	All Active	Active	Active

*Active = active with reduced performance

±15kV ESD-Protected, +5V RS-232 Transceivers

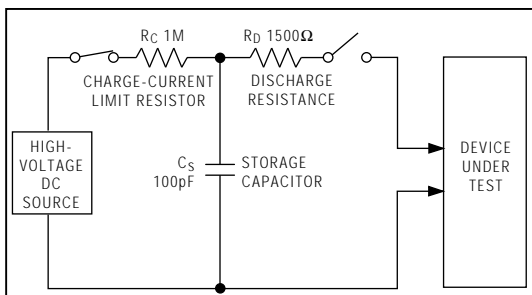

Figure 6a. Human Body ESD Test Model

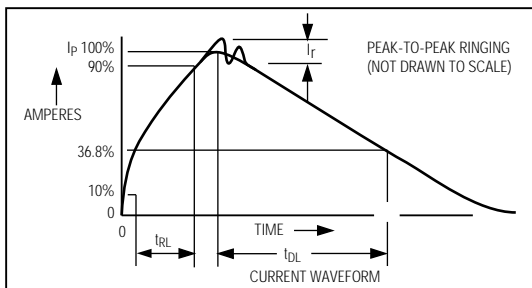

Figure 6b. Human Body Model Current Waveform

±15kV ESD Protection

As with all Maxim devices, ESD-protection structures are incorporated on all pins to protect against electrostatic discharges encountered during handling and assembly. The driver outputs and receiver inputs have extra protection against static electricity. Maxim's engineers developed state-of-the-art structures to protect these pins against ESD of ±15kV without damage. The ESD structures withstand high ESD in all states: normal operation, shutdown, and powered down. After an ESD event, Maxim's MAX202E/MAX203E/MAX211E/MAX213E/MAX232E/MAX241E keep working without latchup, whereas competing RS-232 products can latch and must be powered down to remove latchup.

ESD protection can be tested in various ways; the transmitter outputs and receiver inputs of this product family are characterized for protection to the following limits:

- 1) ±15kV using the Human Body Model
- 2) ±8kV using the contact-discharge method specified in IEC801-2
- 3) ±15kV using IEC801-2's air-gap method.

ESD Test Conditions

ESD performance depends on a variety of conditions. Contact Maxim for a reliability report that documents test set-up, test methodology, and test results.

Human Body Model

Figure 6a shows the Human Body Model, and Figure 6b shows the current waveform it generates when discharged into a low impedance. This model consists of a 100pF capacitor charged to the ESD voltage of interest, which is then discharged into the test device through a 1.5kΩ resistor.

IEC801-2

The IEC801-2 standard covers ESD testing and performance of finished equipment; it does not specifically refer to integrated circuits. The MAX202E/MAX203E/MAX211E/MAX213E/MAX232E/MAX241E help you design equipment that meets level 4 (the highest level) of IEC801-2, without the need for additional ESD-protection components.

The major difference between tests done using the Human Body Model and IEC801-2 is higher peak current in IEC801-2, because series resistance is lower in the IEC801-2 model. Hence, the ESD withstand voltage measured to IEC801-2 is generally lower than that measured using the Human Body Model. Figure 7b shows the current waveform for the 8kV IEC801-2 level-four ESD contact-discharge test.

The air-gap test involves approaching the device with a charged probe. The contact-discharge method connects the probe to the device before the probe is energized.

Machine Model

The Machine Model for ESD tests all pins using a 200pF storage capacitor and zero discharge resistance. Its objective is to emulate the stress caused by contact that occurs with handling and assembly during manufacturing. Of course, all pins require this protection during manufacturing—not just RS-232 inputs and outputs. Therefore, after PC board assembly, the Machine Model is less relevant to I/O ports.

Applications Information

Capacitor Selection

The capacitor type used for C1–C4 is not critical for proper operation. The MAX202E, MAX211E, and MAX213E require 0.1μF capacitors, and the MAX232E and MAX241E require 1μF capacitors, although in all cases capacitors up to 10μF can be used without harm. Ceramic, aluminum-electrolytic, or tantalum capacitors are suggested for the 1μF capacitors, and ceramic

±15kV ESD-Protected, +5V RS-232 Transceivers

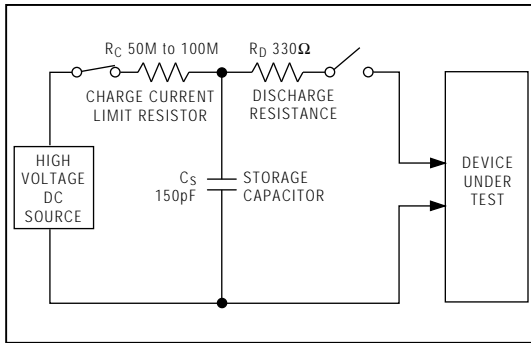

Figure 7a. IEC801-2 ESD Test Model

dielectrics are suggested for the 0.1µF capacitors. When using the minimum recommended capacitor values, make sure the capacitance value does not degrade excessively as the operating temperature varies. If in doubt, use capacitors with a larger (e.g., 2x) nominal value. The capacitors' effective series resistance (ESR), which usually rises at low temperatures, influences the amount of ripple on V+ and V-.

To reduce the output impedance at V+ and V-, use larger capacitors (up to 10µF). This can be useful when "stealing" power from V+ or from V-. The MAX203E has internal charge-pump capacitors.

Bypass VCC to ground with at least 0.1µF. In applications sensitive to power-supply noise generated by the charge pumps, decouple VCC to ground with a capacitor the same size as (or larger than) the charge-pump capacitors (C1-C4).

V+ and V- as Power Supplies

A small amount of power can be drawn from V+ and V-, although this will reduce both driver output swing and noise margins. Increasing the value of the charge-pump capacitors (up to 10µF) helps maintain performance when power is drawn from V+ or V-.

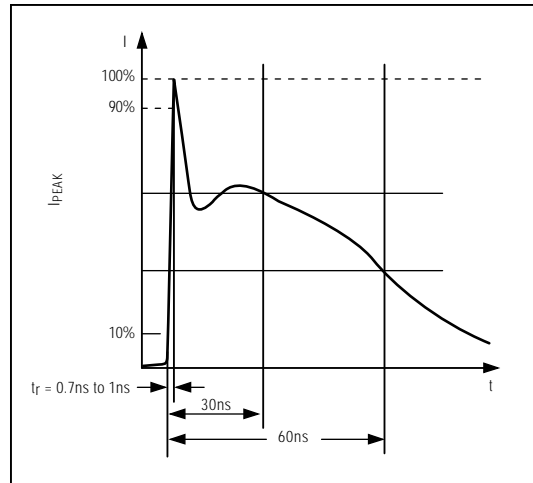

Figure 7b. IEC801-2 ESD Generator Current Waveform

Driving Multiple Receivers

Each transmitter is designed to drive a single receiver. Transmitters can be paralleled to drive multiple receivers.

Driver Outputs when Exiting Shutdown

The driver outputs display no ringing or undesirable transients as they come out of shutdown.

High Data Rates

These transceivers maintain the RS-232 ±5.0V minimum driver output voltages at data rates of over 120kbps. Communication at these high rates is made easier if the capacitive loads on the transmitters are small; i.e., short cables are best.

±15kV ESD-Protected, +5V RS-232 Transceivers

MAX2022E/MAX2032E/MAX211E/MAX213E/MAX2322E/MAX241E

Table 2. Summary of EIA/TIA-232E, V.28 Specifications

PARAMETER	CONDITION	EIA/TIA-232E, V.28 SPECIFICATION
Driver Output Voltage		
0 Level	3kΩ to 7kΩ load	+5.0V to +15V
1 Level	3kΩ to 7kΩ load	-5.0V to -15V
Output Level, Max	No load	±25V
Data Rate	3kΩ ≤ R _L ≤ 7kΩ, C _L ≤ 2500pF	Up to 20kbps
Receiver Input Voltage		
0 Level		+3.0V to +15V
1 Level		-3.0V to -15V
Input Level		±25V
Instantaneous Slew Rate, Max	3kΩ ≤ R _L ≤ 7kΩ, C _L ≤ 2500pF	30V/μs
Driver Output Short-Circuit Current, Max		100mA
Transition Rate on Driver Output	V.28	1ms or 3% of the period
	EIA/TIA-232E	4% of the period
Driver Output Resistance	-2V < V _{OUT} < +2V	300Ω

Table 3. DB9 Cable Connections Commonly Used for EIA/TIAE-232E and V.24 Asynchronous Interfaces

PIN	CONNECTION	
1	Received Line Signal Detector (sometimes called Carrier Detect, DCD)	Handshake from DCE
2	Receive Data (RD)	Data from DCE
3	Transmit Data (TD)	Data from DTE
4	Data Terminal Ready	Handshake from DTE
5	Signal Ground	Reference point for signals
6	Data Set Ready (DSR)	Handshake from DCE
7	Request to Send (RTS)	Handshake from DTE
8	Clear to Send (CTS)	Handshake from DCE
9	Ring Indicator	Handshake from DCE

±15kV ESD-Protected, +5V RS-232 Transceivers

MAX202E/MAX203E/MAX211E/MAX213E/MAX232E/MAX241E

Pin Configurations and Typical Operating Circuits (continued)

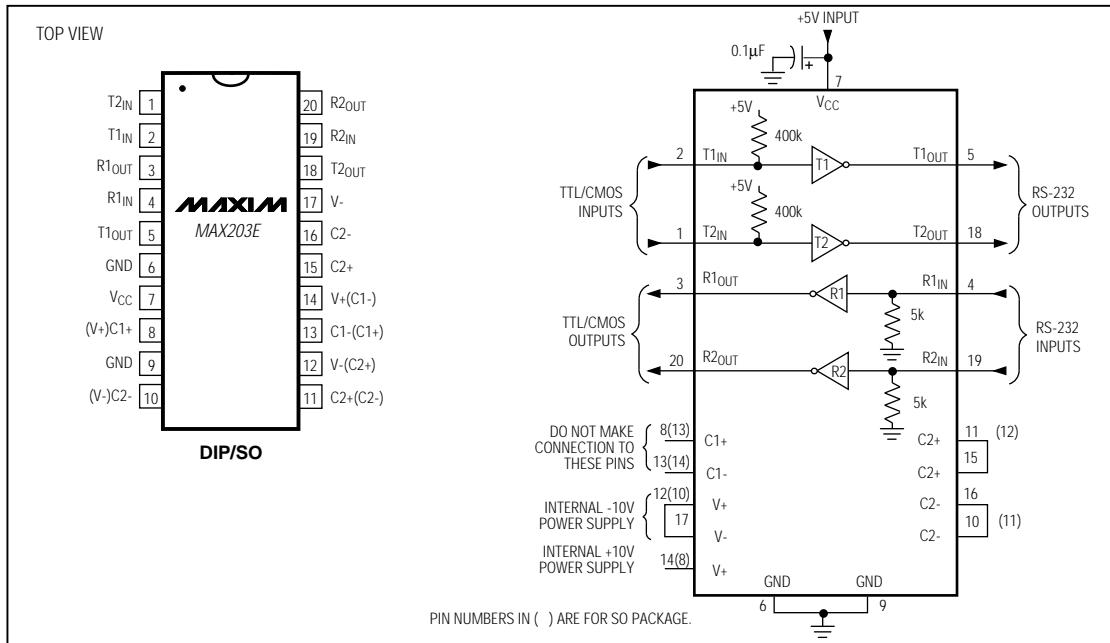
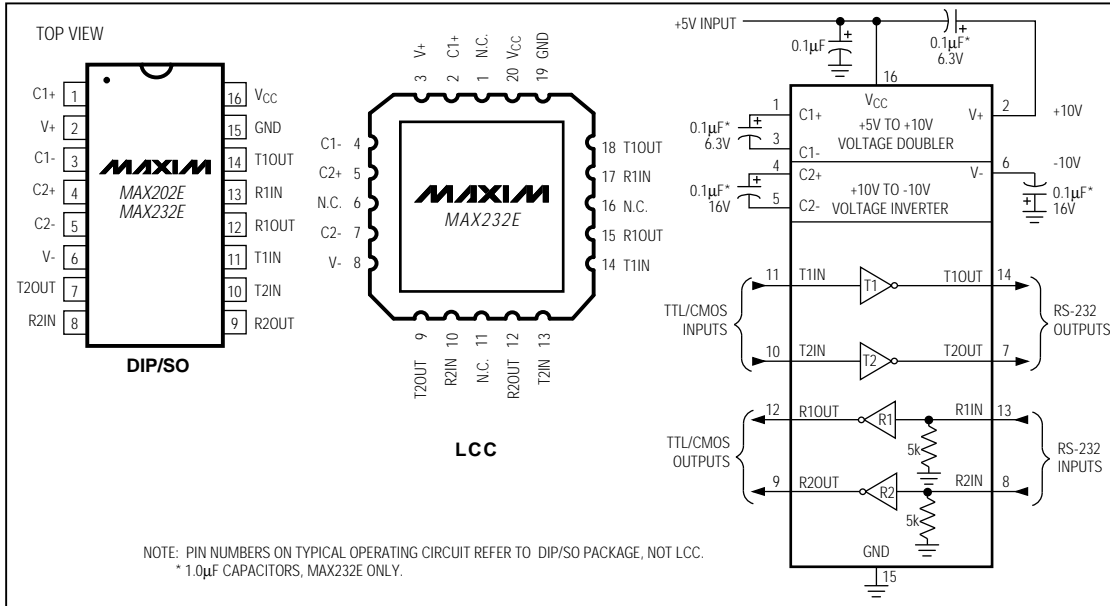

±15kV ESD-Protected, +5V RS-232 Transceivers

MAX202E/MAX203E/MAX211E/MAX213E/MAX232E/MAX241E

_Ordering Information (continued)

PART	TEMP. RANGE	PIN-PACKAGE
MAX203E CPP	0°C to +70°C	20 Plastic DIP
MAX203EWCP	0°C to +70°C	20 Wide SO
MAX203EEPP	-40°C to +85°C	20 Plastic DIP
MAX203EEWP	-40°C to +85°C	20 Wide SO
MAX211E CWI	0°C to +70°C	28 Wide SO
MAX211ECAI	0°C to +70°C	28 SSOP
MAX211ECD	0°C to +70°C	Dice*
MAX211EEWI	-40°C to +85°C	28 Wide SO
MAX211EEAI	-40°C to +85°C	28 SSOP
MAX213E CWI	0°C to +70°C	28 Wide SO
MAX213ECAI	0°C to +70°C	28 SSOP
MAX213ECD	0°C to +70°C	Dice*
MAX213EEWI	-40°C to +85°C	28 Wide SO
MAX213EEAI	-40°C to +85°C	28 SSOP
MAX232E CPE	0°C to +70°C	16 Plastic DIP
MAX232ECSE	0°C to +70°C	16 Narrow SO
MAX232ECWE	0°C to +70°C	16 Wide SO
MAX232ECD	0°C to +70°C	Dice*
MAX232EEPE	-40°C to +85°C	16 Plastic DIP
MAX232EESE	-40°C to +85°C	16 Narrow SO
MAX232EEWE	-40°C to +85°C	16 Wide SO
MAX232EMLP	-55°C to +125°C	20 LCC
MAX232EMJE	-55°C to +125°C	16 CERDIP
MAX241E CWI	0°C to +70°C	28 Wide SO
MAX241ECAI	0°C to +70°C	28 SSOP
MAX241ECD	0°C to +70°C	Dice*
MAX241EEWI	-40°C to +85°C	28 Wide SO
MAX241EEAI	-40°C to +85°C	28 SSOP

*Dice are specified at T_A = +25°C.

±15kV ESD-Protected, +5V RS-232 Transceivers

Chip Topographies

MAX202E/MAX232E

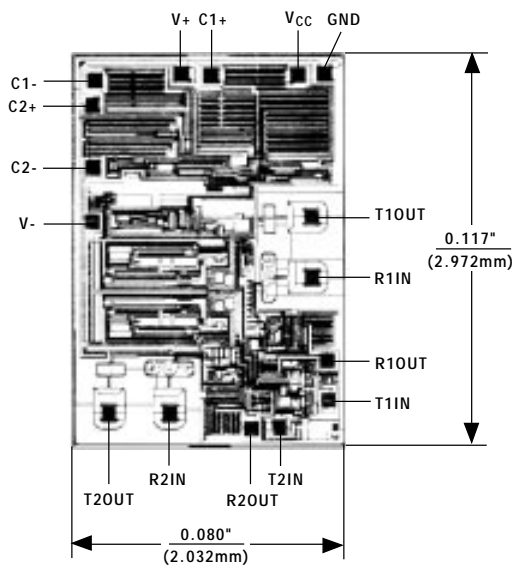

MAX211E/MAX213E/MAX241E

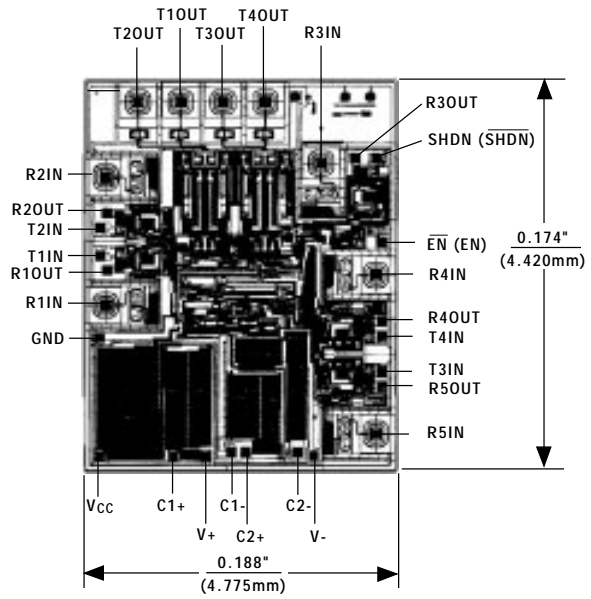

() ARE FOR MAX213E ONLY

TRANSISTOR COUNT: 123
SUBSTRATE CONNECTED TO GND

TRANSISTOR COUNT: 542
SUBSTRATE CONNECTED TO GND

MAX202E/MAX203E/MAX211E/MAX213E/MAX232E/MAX241E

±15kV ESD-Protected, +5V RS-232 Transceivers

Package Information

MAX202E/MAX203E/MAX211E/MAX213E/MAX232E/MAX241E

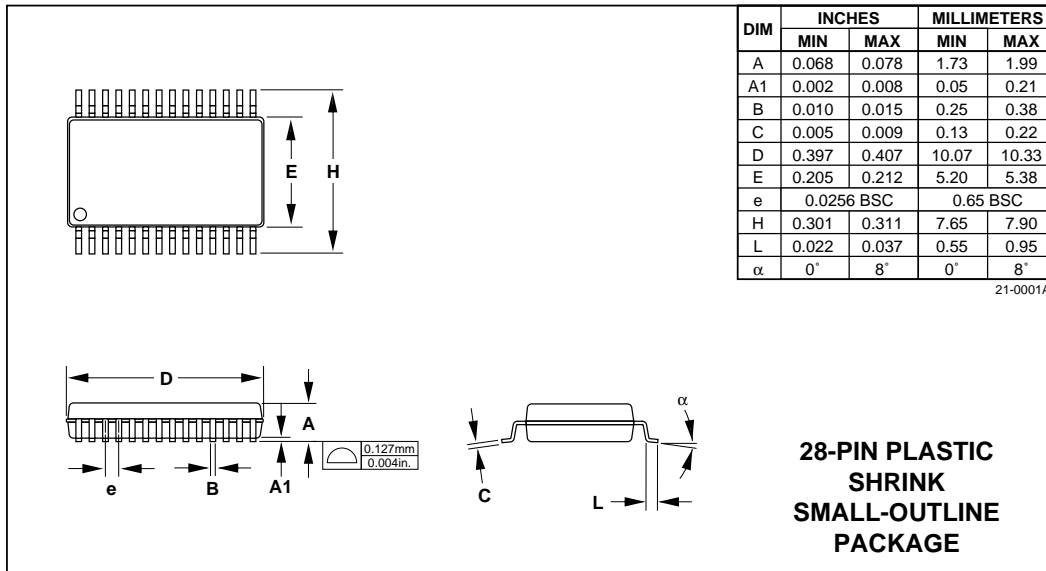
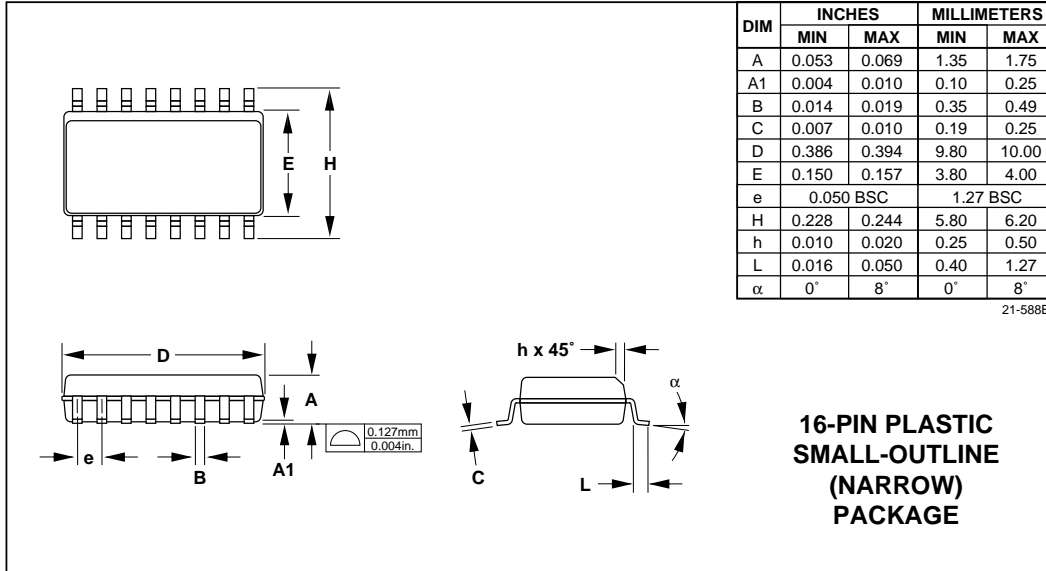

Maxim cannot assume responsibility for use of any circuitry other than circuitry entirely embodied in a Maxim product. No circuit patent licenses are implied. Maxim reserves the right to change the circuitry and specifications without notice at any time.

16 Maxim Integrated Products, 120 San Gabriel Drive, Sunnyvale, CA 94086 (408) 737-7600

© 1995 Maxim Integrated Products

Printed USA

MAXIM is a registered trademark of Maxim Integrated Products.