

# 16-bit Proprietary Microcontroller

CMOS

## F<sup>2</sup>MC-16LX MB90385 Series

### MB90387/387S/F387/F387S/MB90V495G

#### ■ DESCRIPTION

MB90385 series devices are general-purpose high-performance 16-bit micro controllers designed for process control of consumer products, which require high-speed real-time processing. The devices of this series have the built-in full-CAN interface.

The system, inheriting the architecture of F<sup>2</sup>MC\* family, employs additional instruction ready for high-level languages, expanded addressing mode, enhanced multiply-divide instructions, and enriched bit-processing instructions. Furthermore, employment of 32-bit accumulator achieves processing of long-word data (32 bits).

The peripheral resources of MB90385 series include the following:

8/10-bit A/D converter, UART (SCI), 8/16-bit PPG timer, 16-bit input-output timer (16-bit free-run timer, input capture 0, 1, 2, 3 (ICU)), and CAN controller.

\*: "F<sup>2</sup>MC", an abbreviation for FUJITSU Flexible Microcontroller, is a registered trademark of FUJITSU Ltd.

#### ■ FEATURES

##### • Clock

- Built-in PLL clock frequency multiplication circuit
- Selection of machine clocks (PLL clocks) is allowed among frequency division by two on oscillation clock, and multiplication of 1 to 4 times of oscillation clock (for 4-MHz oscillation clock, 4 MHz to 16 MHz).
- Operation by sub-clock (8.192 kHz) is allowed.
- Minimum execution time of instruction: 62.5 ns (when operating with 4-MHz oscillation clock, and 4-time multiplied PLL clock).

(Continued)

#### ■ PACKAGE

48-pin plastic-LQFP

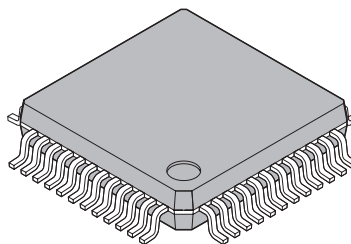

(FPT-48P-M26)

# MB90385 Series

- **16 Mbyte CPU memory space**
  - 24-bit internal addressing
- **Instruction system best suited to controller**
  - Wide choice of data types (bit, byte, word, and long word)
  - Wide choice of addressing modes (23 types)
  - Enhanced multiply-divide instructions and RETI instructions
  - Enhanced high-precision computing with 32-bit accumulator
- **Instruction system compatible with high-level language (C language) and multitask**
  - Employing system stack pointer
  - Enhanced various pointer indirect instructions
  - Barrel shift instructions
- **Increased processing speed**
  - 4-byte instruction queue
- **Powerful interrupt function with 8 levels and 34 factors**
- **Automatic data transfer function independent of CPU**
  - Expanded intelligent I/O service function (EI<sup>2</sup> OS): Maximum of 16 channels
- **Low power consumption (standby) mode**
  - Sleep mode (a mode that halts CPU operating clock)
  - Time-base timer mode (a mode that operates oscillation clock, sub clock, time-base timer and clock timer only)
  - Clock mode (a mode that operates sub clock and clock timer only)
  - Stop mode (a mode that stops oscillation clock and sub clock)
  - CPU blocking operation mode
- **Process**
  - CMOS technology
- **I/O port**
  - General-purpose input/output port (CMOS output) :
    - MB90387, MB90F387 : 34 ports (including 4 high-current output ports)
    - MB90387S, MB90F387S : 36 ports (including 4 high-current output ports)
- **Timer**
  - Time-base timer, clock timer, watchdog timer: 1 channel
  - 8/16-bit PPG timer: 8-bit x 4 channels, or 16-bit x 2 channels
  - 16-bit reload timer: 2 channels
  - 16-bit input/output timer
    - 16-bit free run timer: 1 channel
    - 16-bit input capture: (ICU): 4 channelsInterrupt request is issued upon latching a count value of 16-bit free run timer by detection of an edge on pin input.
- **CAN controller: 1 channel**
  - Compliant with Ver2.0A and Ver2.0B CAN specifications
  - 8 built-in message buffers
  - Transmission rate of 10 Kbps to 1 Mbps (by 16 MHz machine clock)
  - CAN wake-up
- **UART (SCI): 1 channel**
  - Equipped with full-duplex double buffer
  - Clock-asynchronous or clock-synchronous serial transmission is available.

(Continued)

*(Continued)*

- **DTP/External interrupt: 4 channels, CAN wakeup: 1channel**
  - Module for activation of expanded intelligent I/O service (EI<sup>2</sup>OS), and generation of external interrupt.
- **Delay interrupt generator module**
  - Generates interrupt request for task switching.
- **8/10-bit A/D converter: 8 channels**
  - Resolution is selectable between 8-bit and 10-bit.
  - Activation by external trigger input is allowed.
  - Conversion time: 6.125  $\mu$ s (at 16-MHz machine clock, including sampling time)
- **Program patch function**
  - Address matching detection for 2 address pointers.

# MB90385 Series

## ■ PRODUCT LINEUP

Part Number		MB90F387/S	MB90387/S	MB90V495G
Parameter				
Classification		Flash ROM	Mask ROM	Evaluation product
ROM capacity		64 Kbytes		—
RAM capacity		2 Kbytes		6 Kbytes
Process		CMOS		
Package		LQFP-48 (0.50 mm width)		PGA256
Operating power supply voltage		3.5 V to 5.5 V		4.5 V to 5.5 V
Special power supply for emulator*1		—		None
CPU functions		Number of basic instructions : 351 instructions		
		Instruction bit length : 8 bits and 16 bits		
		Instruction length : 1 byte to 7 bytes		
		Data bit length : 1 bit, 8 bits, 16 bits		
		Minimum instruction execution time : 62.5 ns (at 16-MHz machine clock)		
		Interrupt processing time : 1.5 μs at minimum (at 16-MHz machine clock)		
Low power consumption (standby) mode		Sleep mode/Clock mode/Time-base timer mode/ Stop mode/CPU intermittent		
I/O port		General-purpose input/output ports (CMOS output) : 34 ports (36 ports*2) including 4 high-current output ports (P14 to P17)		
Time-base timer		18-bit free-run counter Interrupt cycle : 1.024 ms, 4.096 ms, 16.834 ms, 131.072 ms (with oscillation clock frequency at 4 MHz)		
Watchdog timer		Reset generation cycle: 3.58 ms, 14.33 ms, 57.23 ms, 458.75 ms (with oscillation clock frequency at 4 MHz)		
16-bit input/output timer	16-bit free-run timer	Number of channels: 1 Interrupt upon occurrence of overflow		
	Input capture	Number of channels: 4 Retaining free-run timer value set by pin input (rising edge, falling edge, and both edges)		
16-bit reload timer		Number of channels: 2 16-bit reload timer operation Count clock cycle: 0.25 μs, 0.5 μs, 2.0 μs (at 16-MHz machine clock frequency) External event count is allowed.		
Clock timer		15-bit free-run counter Interrupt cycle: 31.25 ms, 62.5 ms, 12 ms, 250 ms, 500 ms, 1.0 s, 2.0 s (with 8.192 kHz sub clock)		
8/16-bit PPG timer		Number of channels: 2 (four 8-bit channels are available also.) PPG operation is allowed with four 8-bit channels or one 16-bit channel. Outputting pulse wave of arbitrary cycle or arbitrary duty is allowed. Count clock: 62.5 ns to 1 μs (with 16 MHz machine clock)		

(Continued)

(Continued)

Parameter \ Part Number	MB90F387/S	MB90387/S	MB90V495G
Delay interrupt generator module	Interrupt generator module for task switching. Used for realtime OS.		
DTP/External interrupt	Number of inputs: 4 Activated by rising edge, falling edge, "H" level or "L" level input. External interrupt or expanded intelligent I/O service (EI <sup>2</sup> OS) is available.		
8/10-bit A/D converter	Number of channels: 8 Resolution: Selectable 10-bit or 8-bit. Conversion time: 6.125 μs (at 16-MHz machine clock, including sampling time) Sequential conversion of two or more successive channels is allowed. (Setting a maximum of 8 channels is allowed.) Single conversion mode : Selected channel is converted only once. Sequential conversion mode: Selected channel is converted repetitively. Halt conversion mode : Conversion of selected channel is stopped and activated alternately.		
UART(SCI)	Number of channels: 1 Clock-synchronous transfer: 62.5 Kbps to 2 Mbps Clock-asynchronous transfer: 9,615 bps to 500 Kbps Communication is allowed by bi-directional serial communication function and master/slave type connection.		
CAN	Compliant with Ver 2.0A and Ver 2.0B CAN specifications. 8 built-in message buffers. Transmission rate of 10 Kbps to 1 Mbps (by 16 MHz machine clock) CAN wake-up		

\*1 : Settings of DIP switch S2 for using emulation pod MB2145-507. For details, see MB2145-507 Hardware Manual (2.7 Power Pin solely for Emulator).

\*2 : MB90387S, MB90F387S

## ■ PACKAGES AND PRODUCT MODELS

Package	MB90F387/S	MB90387/S
FPT-48P-M26	○	○

○ : Yes × : No

Note : Refer to ■ PACKAGE DIMENSION for details of the package.

## ■ PRODUCT COMPARISON

### Memory space

When testing with test product for evaluation, check the differences between the product and a product to be used actually. Pay attention to the following points:

- The MB90V495G has no built-in ROM. However, a special-purpose development tool allows the operations as those of one with built-in ROM. ROM capacity depends on settings on a development tool.
- On MB90V495G, an image from FF4000<sub>H</sub> to FFFFFFF<sub>H</sub> is viewed on 00 bank and an image of FE0000<sub>H</sub> to FF3FFF<sub>H</sub> is viewed only on FE bank and FF bank. (Modified on settings of a development tool.)
- On MB90F387/S/387/S, an image from FF4000<sub>H</sub> to FFFFFFF<sub>H</sub> is viewed on 00 bank and an image of FE0000<sub>H</sub> to FF3FFF<sub>H</sub> is viewed only on FF bank.

# MB90385 Series

## ■ PIN ASSIGNMENT

(TOP VIEW)

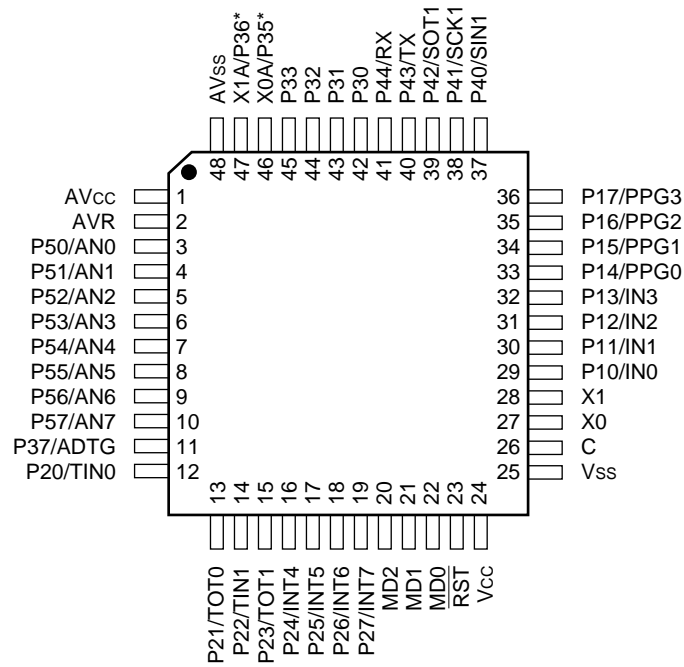

(FPT-48P-M26)

\* : MB90387, MB90F387 : X1A, X0A  
 MB90387S, MB90F387S: P36, P35

## ■ PIN DESCRIPTION

Pin No.	Pin name	Circuit type	Function
1	AVcc	—	Vcc power input pin for A/D converter.
2	AVR	—	Power (Vref+) input pin for A/D converter. Use as input for Vcc or lower.
3 to 10	P50 to P57	E	General-purpose input/output ports.
	AN0 to AN7		Functions as analog input pin for A/D converter. Valid when analog input setting is "enabled."
11	P37	D	General-purpose input/output ports.
	ADTG		Function as an external trigger input pin for A/D converter. Use the pin by setting as input port.
12	P20	D	General-purpose input/output ports.
	TIN0		Function as an event input pin for reload timer 0. Use the pin by setting as input port.
13	P21	D	General-purpose input/output ports.
	TOT0		Function as an event output pin for reload timer 0. Valid only when output setting is "enabled."
14	P22	D	General-purpose input/output ports.
	TIN1		Function as an event input pin for reload timer 1. Use the pin by setting as input port.
15	P23	D	General-purpose input/output ports.
	TOT1		Function as an event output pin for reload timer 1. Valid only when output setting is "enabled."
16 to 19	P24 to P27	D	General-purpose input/output ports.
	INT4 to INT7		Functions as external interrupt input pin. Use the pin by setting as input port.
20	MD2	F	Input pin for specifying operation mode. Connect directly to Vss.
21	MD1	C	Input pin for specifying operation mode. Connect directly to Vcc.
22	MD0	C	Input pin for specifying operation mode. Connect directly to Vcc.
23	$\overline{RST}$	B	External reset input pin.
24	Vcc	—	Power source (5 V) input pin.
25	Vss	—	Power source (0 V) input pin.
26	C	—	Capacitor pin for stabilizing power source. Connect a ceramic capacitor of approximately 0.1 $\mu$ F.
27	X0	A	Pin for high-rate oscillation.
28	X1	A	Pin for high-rate oscillation.
29 to 32	P10 to P13	D	General-purpose input/output ports.
	IN0 to IN3		Functions as trigger input pins of input capture channels 0 to 3. Use the pins by setting as input ports.

(Continued)

# MB90385 Series

(Continued)

Pin No.	Pin name	Circuit type	Function
33 to 36	P14 to P17	G	General-purpose input/output ports. High-current output ports.
	PPG0 to PPG3		Functions as output pin of PPG timers 01 and 23. Valid when output setting is "enabled."
37	P40	D	General-purpose input/output port.
	SIN1		Serial data input pin for UART. Use the pin by setting as input port.
38	P41	D	General-purpose input/output port.
	SCK1		Serial clock input pin for UART. Valid only when serial clock input/output setting on UART is "enabled."
39	P42	D	General-purpose input/output port.
	SOT1		Serial data input pin for UART. Valid only when serial data input/output setting on UART is "enabled."
40	P43	D	General-purpose input/output port.
	TX		Transmission output pin for CAN. Valid only when output setting is "enabled."
41	P44	D	General-purpose input/output port.
	RX		Transmission output pin for CAN. Valid only when output setting is "enabled."
42 to 45	P30 to P33	D	General-purpose input/output ports.
46	X0A*	A	Pin for low-rate oscillation.
	P35*		General-purpose input/output port.
47	X1A*	A	Pin for low-rate oscillation.
	P36*		General-purpose input/output port.
48	AVss	—	Vss power source input pin for A/D converter.

\* : MB90387, MB90F387 : X1A, X0A  
 MB90387S, MB90F387S: P36, P35

## ■ I/O CIRCUIT TYPE

Type	Circuit	Remarks
A		<ul style="list-style-type: none"> <li>• High-rate oscillation feedback resistor, approx.1 MΩ</li> <li>• Low-rate oscillation feedback resistor, approx.10 MΩ</li> </ul>
B		<ul style="list-style-type: none"> <li>• Hysteresis input with pull-up resistor.</li> <li>• Pull-up resistor, approx.50 kΩ</li> </ul>
C		<ul style="list-style-type: none"> <li>• Hysteresis input</li> </ul>
D		<ul style="list-style-type: none"> <li>• CMOS hysteresis input</li> <li>• CMOS level output</li> <li>• Standby control provided</li> </ul>
E		<ul style="list-style-type: none"> <li>• CMOS hysteresis input</li> <li>• CMOS level output</li> <li>• Shared for analog input pin</li> <li>• Standby control provided</li> </ul>

(Continued)

# MB90385 Series

(Continued)

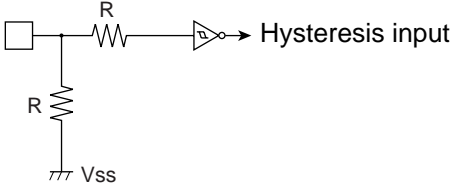
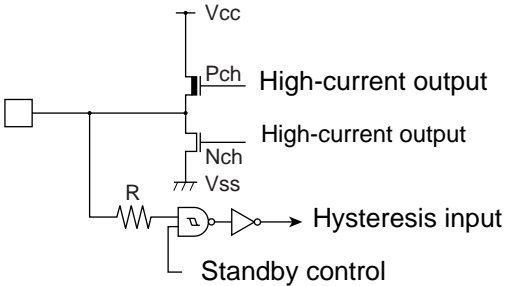
Type	Circuit	Remarks
F		<ul style="list-style-type: none"> <li>• Hysteresis input with pull-down resistor</li> <li>• Pull-down resistor, approx. 50 kΩ</li> <li>• FLASH product is not provided with pull-down resistor.</li> </ul>
G		<ul style="list-style-type: none"> <li>• CMOS hysteresis input</li> <li>• CMOS level output (high-current output)</li> <li>• Standby control provided</li> </ul>

## ■ HANDLING DEVICES

### • Do Not Exceed Maximum Rating (preventing “latch up”)

- On a CMOS IC, latch-up may occur when applying a voltage higher than  $V_{cc}$  or a voltage lower than  $V_{ss}$  to input or output pin, which has no middle or high withstand voltage. Latch-up may also occur when a voltage exceeding maximum rating is applied across  $V_{cc}$  and  $V_{ss}$ .
- Latch-up causes drastic increase of power current, which may lead to destruction of elements by heat. Extreme caution must be taken not to exceed maximum rating.
- When turning on and off analog power source, take extra care not to apply an analog power voltages ( $AV_{cc}$  and  $AVR$ ) and analog input voltage that are higher than digital power voltage ( $V_{cc}$ ).

### • Handling Unused Pins

- Leaving unused input pins open may cause permanent destruction by malfunction or latch-up. Apply pull-up or pull-down process to the unused pins using resistors of 2 k $\Omega$  or higher. Leave unused input pins open under output status, or process as input pins if they are under input status.

### • Using External Clock

- When using an external clock, drive only X0 pin and leave X1 pin open. An example of using an external clock is shown below.

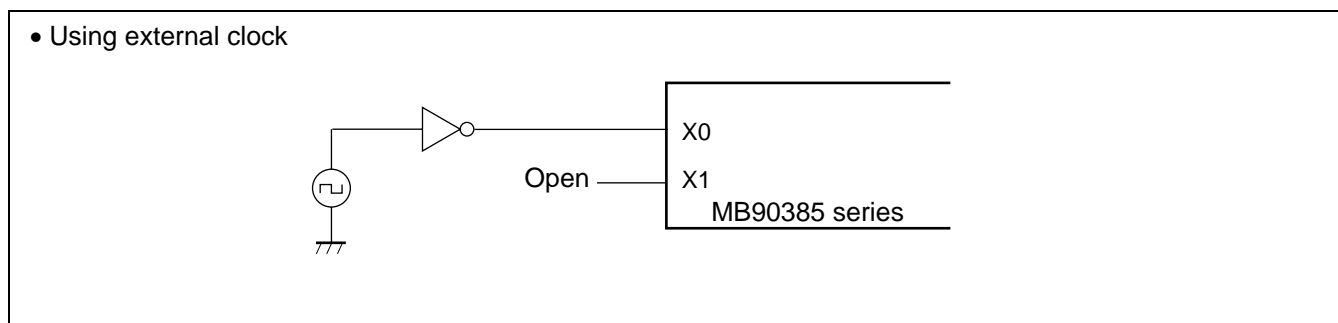

### • Notes When Using No Sub Clock

- If an oscillator is not connected to X0A and X1A pin, apply pull-down resistor to X0A pin and leave X1A pin open.

### • About Power Supply Pins

- If two or more  $V_{cc}$  and  $V_{ss}$  exist, the pins that should be at the same potential are connected to each other inside the device. For reducing unwanted emissions and preventing malfunction of strobe signals caused by increase of ground level, however, be sure to connect the  $V_{cc}$  and  $V_{ss}$  pins to the power source and the ground externally.
- Pay attention to connect a power supply to  $V_{cc}$  and  $V_{ss}$  of MB90385 series device in a lowest-possible impedance.
- Near pins of MB90385 series device, connecting a bypass capacitor is recommended at 0.1  $\mu\text{F}$  across  $V_{cc}$  and  $V_{ss}$ .

### • Crystal Oscillator Circuit

- Noises around X0 and X1 pins cause malfunctions on a MB90385 series device. Design a print circuit so that X0 and X1 pins, an crystal oscillator (or a ceramic oscillator), and bypass capacitor to the ground become as close as possible to each other. Furthermore, avoid wires to X0 and X1 pins crossing each other as much as possible.
- Print circuit designing that surrounds X0 and X1 pins with grounding wires, which ensures stable operation, is strongly recommended.

### • Caution on Operations during PLL Clock Mode

- If the PLL clock mode is selected, the microcontroller attempt to be working with the self-oscillating circuit even when there is no external oscillator or external clock input is stopped. Performance of this operation, however, cannot be guaranteed.

# MB90385 Series

- **Sequence of Turning on Power of A/D Converter and Applying Analog Input**
  - Be sure to turn on digital power ( $V_{CC}$ ) before applying signals to the A/D converter and applying analog input signals (AN0 to AN7 pins).
  - Be sure to turn off the power of A/D converter and analog input before turning off the digital power source.
  - Be sure not to apply AVR exceeding  $AV_{CC}$  when turning on and off. (No problems occur if analog and digital power is turned on and off simultaneously.)
- **Handling Pins When A/D Converter is Not Used**
  - If the A/D converter is not used, connect the pins under the following conditions: “ $AV_{CC}=AVR=V_{CC}$ ,” and “ $AV_{SS}=V_{SS}$ ”
- **Note on Turning on Power**
  - For preventing malfunctions on built-in step-down circuit, maintain a minimum of 50  $\mu$ s of voltage rising time (between 0.2 V and 2.7V) when turning on the power.
- **Stabilization of supply voltage**
  - A sudden change in the supply voltage may cause the device to malfunction even within the specified  $V_{CC}$  supply voltage operating range. Therefore, the  $V_{CC}$  supply voltage should be stabilized.  
For reference, the supply voltage should be controlled so that  $V_{CC}$  ripple variations (peak-to-peak values) at commercial frequencies (50 Hz to 60 Hz) fall below 10% of the standard  $V_{CC}$  supply voltage and the coefficient of fluctuation does not exceed 0.1 V/ms at instantaneous power switching.

## ■ BLOCK DIAGRAM

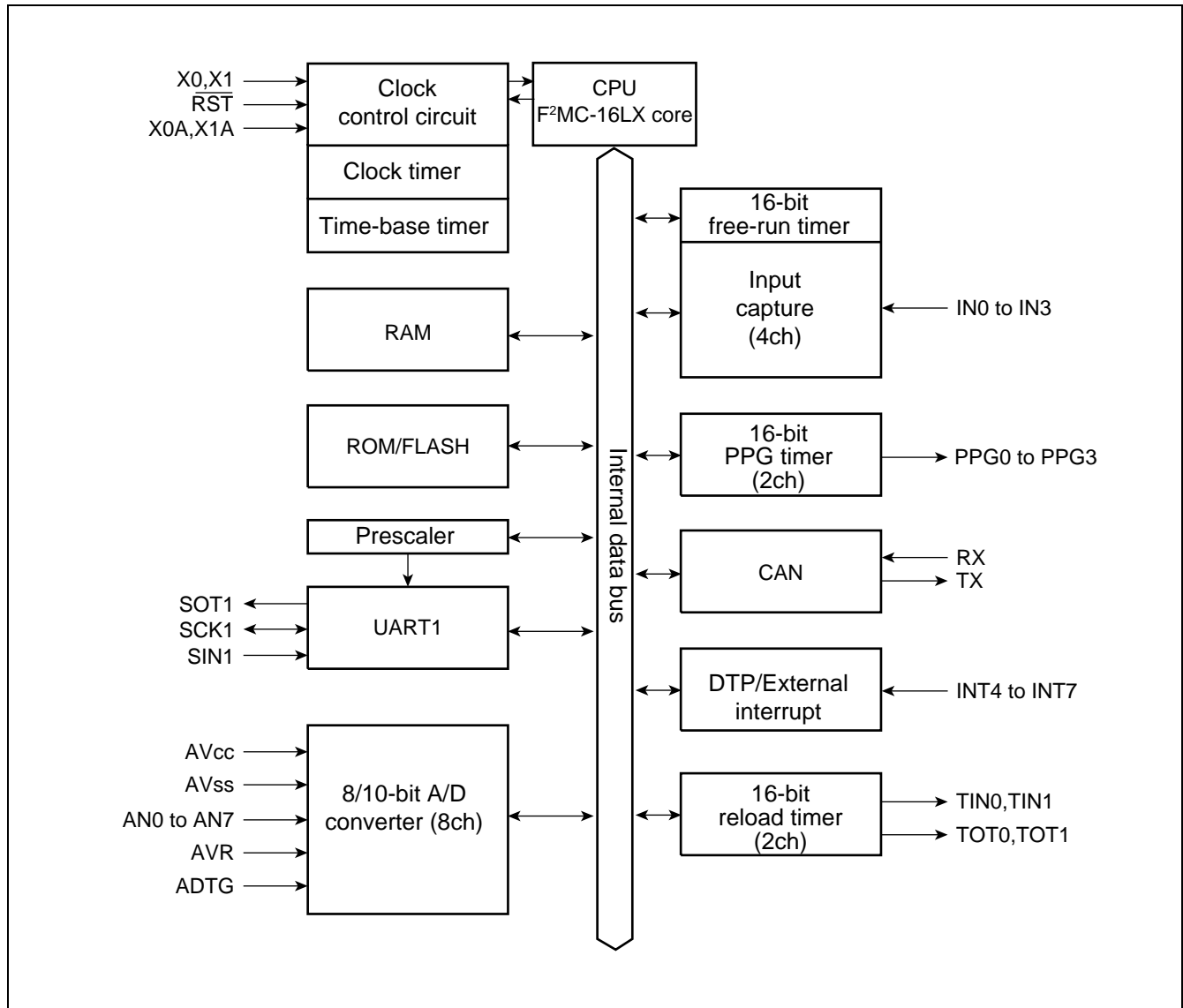

# MB90385 Series

## MEMORY MAP

MB90385 series allows specifying a memory access mode “single chip mode.”

### 1. Memory allocation of MB90385

MB90385 series model has 24-bit wide internal address bus and up to 24-bit bus of external address bus. A maximum of 16 Mbyte memory space of external access memory is accessible.

### 2. Memory map

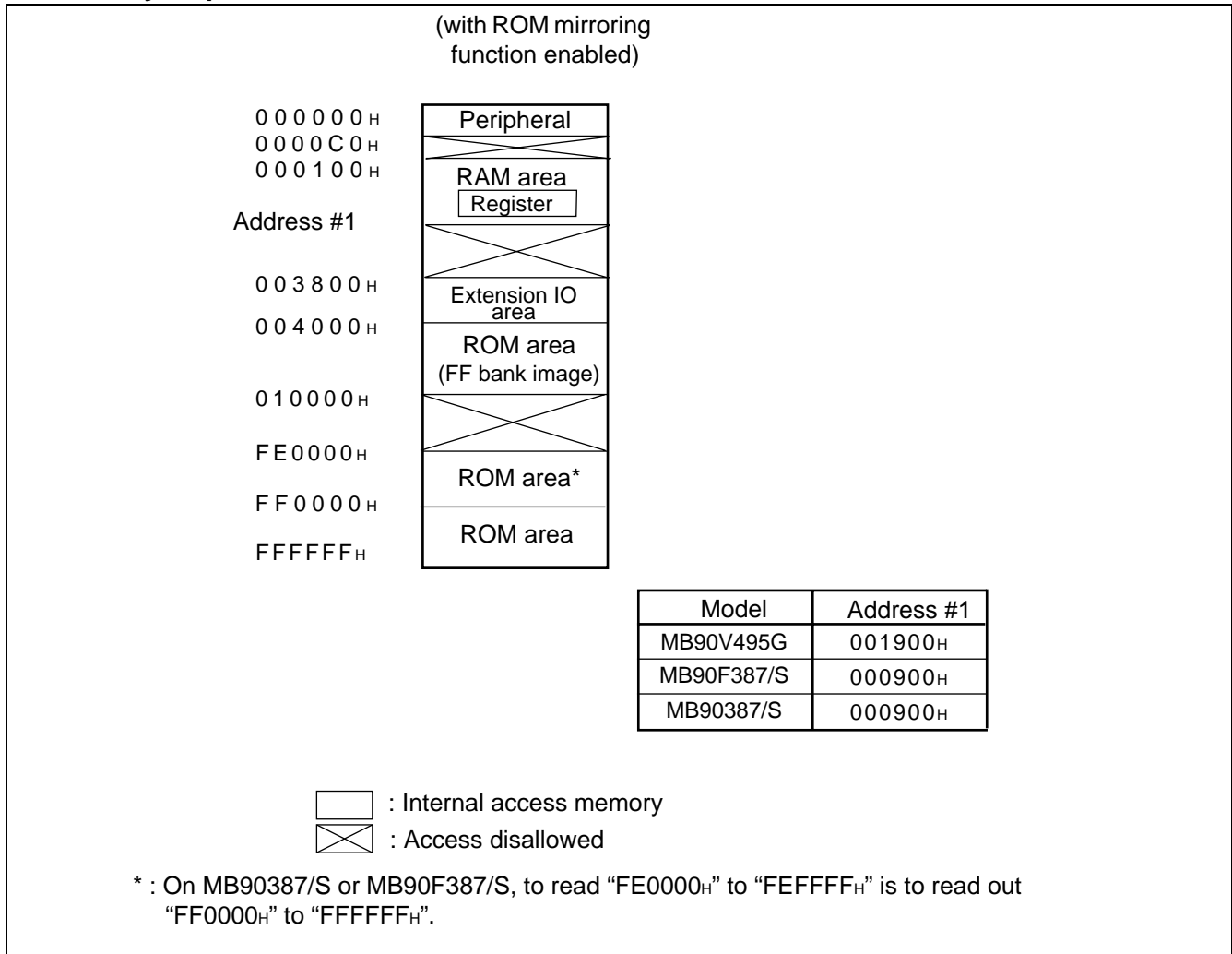

Note : When internal ROM is operating, F<sup>2</sup>MC-16LX allows viewing ROM data image on FF bank at upper-level of 00 bank. This function is called “mirroring ROM,” which allows effective use of C compiler small model. F<sup>2</sup>MC-16LX assigns the same low order 16-bit address to FF bank and 00 bank, which allows referencing table in ROM without specifying “far” using pointer. For example, when accessing to “00C000H”, ROM data at “FFC000H” is accessed actually. However, because ROM area of FF bank exceeds 48 Kbytes, viewing all areas is not possible on 00 bank image. Because ROM data of “FF4000H” to “FFFFFFH” is viewed on “004000H” to “00FFFFH” image, store a ROM data table in area “FF4000H” to “FFFFFFH.”

## ■ I/O MAP

Address	Register abbreviation	Register	Read/Write	Resource	Initial value
000000 <sub>H</sub>	(Reserved area) *				
000001 <sub>H</sub>	PDR1	Port 1 data register	R/W	Port 1	XXXXXXXX <sub>B</sub>
000002 <sub>H</sub>	PDR2	Port 2 data register	R/W	Port 2	XXXXXXXX <sub>B</sub>
000003 <sub>H</sub>	PDR3	Port 3 data register	R/W	Port 3	XXXXXXXX <sub>B</sub>
000004 <sub>H</sub>	PDR4	Port 4 data register	R/W	Port 4	XXXXXXXX <sub>B</sub>
000005 <sub>H</sub>	PDR5	Port 5 data register	R/W	Port 5	XXXXXXXX <sub>B</sub>
000006 <sub>H</sub> to 000010 <sub>H</sub>	(Reserved area) *				
000011 <sub>H</sub>	DDR1	Port 1 direction data register	R/W	Port 1	00000000 <sub>B</sub>
000012 <sub>H</sub>	DDR2	Port 2 direction data register	R/W	Port 2	00000000 <sub>B</sub>
000013 <sub>H</sub>	DDR3	Port 3 direction data register	R/W	Port 3	000X0000 <sub>B</sub>
000014 <sub>H</sub>	DDR4	Port 4 direction data register	R/W	Port 4	XXX00000 <sub>B</sub>
000015 <sub>H</sub>	DDR5	Port 5 direction data register	R/W	Port 5	00000000 <sub>B</sub>
000016 <sub>H</sub> to 00001A <sub>H</sub>	(Reserved area) *				
00001B <sub>H</sub>	ADER	Analog input permission register	R/W	8/10-bit A/D converter	11111111 <sub>B</sub>
00001C <sub>H</sub> to 000025 <sub>H</sub>	(Reserved area) *				
000026 <sub>H</sub>	SMR1	Serial mode register 1	R/W	UART1	00000000 <sub>B</sub>
000027 <sub>H</sub>	SCR1	Serial control register 1	R/W, W		00000100 <sub>B</sub>
000028 <sub>H</sub>	SIDR1/ SODR1	Serial input data register 1/ Serial output data register 1	R, W		XXXXXXXX <sub>B</sub>
000029 <sub>H</sub>	SSR1	Serial status data register 1	R, R/W		00001000 <sub>B</sub>
00002A <sub>H</sub>	(Reserved area) *				
00002B <sub>H</sub>	CDCR1	Communication prescaler control register 1	R/W	UART1	0XXX0000 <sub>B</sub>
00002C <sub>H</sub> to 00002F <sub>H</sub>	(Reserved area) *				
000030 <sub>H</sub>	ENIR	DTP/External interrupt permission register	R/W	DTP/External interrupt	00000000 <sub>B</sub>
000031 <sub>H</sub>	EIRR	DTP/External interrupt permission register	R/W		XXXXXXXX <sub>B</sub>
000032 <sub>H</sub>	ELVR	Detection level setting register	R/W		00000000 <sub>B</sub>
000033 <sub>H</sub>			R/W		00000000 <sub>B</sub>

(Continued)

# MB90385 Series

Address	Register abbreviation	Register	Read/Write	Resource	Initial value
000034 <sub>H</sub>	ADCS	A/D control status register	R/W	8/10-bit A/D converter	00000000 <sub>B</sub>
000035 <sub>H</sub>			R/W, W		00000000 <sub>B</sub>
000036 <sub>H</sub>	ADCR	A/D data register	W, R		XXXXXXXX <sub>B</sub>
000037 <sub>H</sub>			R		00101XXX <sub>B</sub>
000038 <sub>H</sub> to 00003F <sub>H</sub>	(Reserved area) *				
000040 <sub>H</sub>	PPGC0	PPG0 operation mode control register	R/W, W	8/16-bit PPG timer 0/1	0X000XX1 <sub>B</sub>
000041 <sub>H</sub>	PPGC1	PPG1 operation mode control register	R/W, W		0X000001 <sub>B</sub>
000042 <sub>H</sub>	PPG01	PPG0/1 count clock selection register	R/W		000000XX <sub>B</sub>
000043 <sub>H</sub>	(Reserved area) *				
000044 <sub>H</sub>	PPGC2	PPG2 operation mode control register	R/W, W	8/16-bit PPG timer 2/3	0X000XX1 <sub>B</sub>
000045 <sub>H</sub>	PPGC3	PPG3 operation mode control register	R/W, W		0X000001 <sub>B</sub>
000046 <sub>H</sub>	PPG23	PPG2/3 count clock selection register	R/W		000000XX <sub>B</sub>
000047 <sub>H</sub> to 00004F <sub>H</sub>	(Reserved area) *				
000050 <sub>H</sub>	IPCP0	Input capture data register 0	R	16-bit input/output timer	XXXXXXXX <sub>B</sub>
000051 <sub>H</sub>					XXXXXXXX <sub>B</sub>
000052 <sub>H</sub>	IPCP1	Input capture data register 1	R		XXXXXXXX <sub>B</sub>
000053 <sub>H</sub>					XXXXXXXX <sub>B</sub>
000054 <sub>H</sub>	ICS01	Input capture control status register	R/W		00000000 <sub>B</sub>
000055 <sub>H</sub>	ICS23				00000000 <sub>B</sub>
000056 <sub>H</sub>	TCDT	Timer counter data register	R/W		00000000 <sub>B</sub>
000057 <sub>H</sub>					00000000 <sub>B</sub>
000058 <sub>H</sub>	TCCS	Timer counter control status register	R/W		00000000 <sub>B</sub>
000059 <sub>H</sub>	(Reserved area) *				
00005A <sub>H</sub>	IPCP2	Input capture data register 2	R	16-bit input/output timer	XXXXXXXX <sub>B</sub>
00005B <sub>H</sub>					XXXXXXXX <sub>B</sub>
00005C <sub>H</sub>	IPCP3	Input capture data register 3	R		XXXXXXXX <sub>B</sub>
00005D <sub>H</sub>					XXXXXXXX <sub>B</sub>

(Continued)

# MB90385 Series

Address	Register abbreviation	Register	Read/Write	Resource	Initial value
00005E <sub>H</sub> to 000065 <sub>H</sub>	(Reserved area) *				
000066 <sub>H</sub>	TMCSR0	Timer control status register	R/W	16-bit reload timer 0	00000000 <sub>B</sub>
000067 <sub>H</sub>			R/W		XXXX0000 <sub>B</sub>
000068 <sub>H</sub>	TMCSR1		R/W	16-bit reload timer 1	00000000 <sub>B</sub>
000069 <sub>H</sub>			R/W		XXXX0000 <sub>B</sub>
00006A <sub>H</sub> to 00006E <sub>H</sub>	(Reserved area) *				
00006F <sub>H</sub>	ROMM	ROM mirroring function selection register	W	ROM mirroring function selection module	XXXXXXXX1 <sub>B</sub>
000070 <sub>H</sub> to 00007F <sub>H</sub>	(Reserved area) *				
000080 <sub>H</sub>	BVALR	Message buffer enabling register	R/W	CAN controller	00000000 <sub>B</sub>
000081 <sub>H</sub>	(Reserved area) *				
000082 <sub>H</sub>	TREQR	Send request register	R/W	CAN controller	00000000 <sub>B</sub>
000083 <sub>H</sub>	(Reserved area) *				
000084 <sub>H</sub>	TCANR	Send cancel register	W	CAN controller	00000000 <sub>B</sub>
000085 <sub>H</sub>	(Reserved area) *				
000086 <sub>H</sub>	TCR	Send completion register	R/W	CAN controller	00000000 <sub>B</sub>
000087 <sub>H</sub>	(Reserved area) *				
000088 <sub>H</sub>	RCR	Receive completion register	R/W	CAN controller	00000000 <sub>B</sub>
000089 <sub>H</sub>	(Reserved area) *				
00008A <sub>H</sub>	RRTRR	Receive RTR register	R/W	CAN controller	00000000 <sub>B</sub>
00008B <sub>H</sub>	(Reserved area) *				
00008C <sub>H</sub>	ROVRR	Receive overrun register	R/W	CAN controller	00000000 <sub>B</sub>
00008D <sub>H</sub>	(Reserved area) *				
00008E <sub>H</sub>	RIER	Receive completion interrupt permission register	R/W	CAN controller	00000000 <sub>B</sub>
00008F <sub>H</sub> to 00009D <sub>H</sub>	(Reserved area) *				
00009E <sub>H</sub>	PACSR	Address detection control register	R/W	Address matching detection function	00000000 <sub>B</sub>
00009F <sub>H</sub>	DIRR	Delay interrupt request generation/release register	R/W	Delay interrupt generation module	XXXXXXXX0 <sub>B</sub>

(Continued)

# MB90385 Series

Address	Register abbreviation	Register	Read/Write	Resource	Initial value
0000A0 <sub>H</sub>	LPMCR	Lower power consumption mode control register	W,R/W	Lower power consumption mode	00011000 <sub>B</sub>
0000A1 <sub>H</sub>	CKSCR	Clock selection register	R,R/W	Clock	11111100 <sub>B</sub>
0000A2 <sub>H</sub> to 0000A7 <sub>H</sub>	(Reserved area) *				
0000A8 <sub>H</sub>	WDTC	Watchdog timer control register	R,W	Watchdog timer	XXXXX111 <sub>B</sub>
0000A9 <sub>H</sub>	TBTC	Time-base timer control register	R/W,W	Time-base timer	1XX00100 <sub>B</sub>
0000AA <sub>H</sub>	WTC	Clock timer control register	R,R/W	Clock timer	1X001000 <sub>B</sub>
0000AB <sub>H</sub> to 0000AD <sub>H</sub>	(Reserved area) *				
0000AE <sub>H</sub>	FMCS	Flash memory control status register	R,W,R/W	512k-bit flash memory	000X0000 <sub>B</sub>
0000AF <sub>H</sub>	(Reserved area) *				
0000B0 <sub>H</sub>	ICR00	Interrupt control register 00	R/W	Interrupt controller	00000111 <sub>B</sub>
0000B1 <sub>H</sub>	ICR01	Interrupt control register 01			00000111 <sub>B</sub>
0000B2 <sub>H</sub>	ICR02	Interrupt control register 02			00000111 <sub>B</sub>
0000B3 <sub>H</sub>	ICR03	Interrupt control register 03			00000111 <sub>B</sub>
0000B4 <sub>H</sub>	ICR04	Interrupt control register 04			00000111 <sub>B</sub>
0000B5 <sub>H</sub>	ICR05	Interrupt control register 05			00000111 <sub>B</sub>
0000B6 <sub>H</sub>	ICR06	Interrupt control register 06			00000111 <sub>B</sub>
0000B7 <sub>H</sub>	ICR07	Interrupt control register 07			00000111 <sub>B</sub>
0000B8 <sub>H</sub>	ICR08	Interrupt control register 08			00000111 <sub>B</sub>
0000B9 <sub>H</sub>	ICR09	Interrupt control register 09			00000111 <sub>B</sub>
0000BA <sub>H</sub>	ICR10	Interrupt control register 10			00000111 <sub>B</sub>
0000BB <sub>H</sub>	ICR11	Interrupt control register 11			00000111 <sub>B</sub>
0000BC <sub>H</sub>	ICR12	Interrupt control register 12			00000111 <sub>B</sub>
0000BD <sub>H</sub>	ICR13	Interrupt control register 13			00000111 <sub>B</sub>
0000BE <sub>H</sub>	ICR14	Interrupt control register 14			00000111 <sub>B</sub>
0000BF <sub>H</sub>	ICR15	Interrupt control register 15			00000111 <sub>B</sub>
0000C0 <sub>H</sub> to 0000FF <sub>H</sub>	(Reserved area) *				

(Continued)

# MB90385 Series

Address	Register abbreviation	Register	Read/Write	Resource	Initial value
001FF0 <sub>H</sub>	PADR0	Detection address setting register 0 (low-order)	R/W	Address matching detection function	XXXXXXXX <sub>B</sub>
001FF1 <sub>H</sub>		Detection address setting register 0 (middle-order)			XXXXXXXX <sub>B</sub>
001FF2 <sub>H</sub>		Detection address setting register 0 (high-order)			XXXXXXXX <sub>B</sub>
001FF3 <sub>H</sub>	PADR1	Detection address setting register 1 (low-order)	R/W		XXXXXXXX <sub>B</sub>
001FF4 <sub>H</sub>		Detection address setting register 1 (middle-order)			XXXXXXXX <sub>B</sub>
001FF5 <sub>H</sub>		Detection address setting register 1 (high-order)			XXXXXXXX <sub>B</sub>
003900 <sub>H</sub>	TMR0/ TMRLR0	16-bit timer register 0/16-bit reload register	R,W	16-bit reload timer 0	XXXXXXXX <sub>B</sub>
003901 <sub>H</sub>					XXXXXXXX <sub>B</sub>
003902 <sub>H</sub>	TMR1/ TMRLR1	16-bit timer register 1/16-bit reload register	R,W	16-bit reload timer 1	XXXXXXXX <sub>B</sub>
003903 <sub>H</sub>					XXXXXXXX <sub>B</sub>
003904 <sub>H</sub> to 00390F <sub>H</sub>	(Reserved area) *				
003910 <sub>H</sub>	PRL0	PPG0 reload register L	R/W	8/16-bit PPG timer	XXXXXXXX <sub>B</sub>
003911 <sub>H</sub>	PRLH0	PPG0 reload register H	R/W		XXXXXXXX <sub>B</sub>
003912 <sub>H</sub>	PRL1	PPG1 reload register L	R/W		XXXXXXXX <sub>B</sub>
003913 <sub>H</sub>	PRLH1	PPG1 reload register H	R/W		XXXXXXXX <sub>B</sub>
003914 <sub>H</sub>	PRL2	PPG2 reload register L	R/W		XXXXXXXX <sub>B</sub>
003915 <sub>H</sub>	PRLH2	PPG2 reload register H	R/W		XXXXXXXX <sub>B</sub>
003916 <sub>H</sub>	PRL3	PPG3 reload register L	R/W		XXXXXXXX <sub>B</sub>
003917 <sub>H</sub>	PRLH3	PPG3 reload register H	R/W		XXXXXXXX <sub>B</sub>
003918 <sub>H</sub> to 00392F <sub>H</sub>	(Reserved area) *				
003930 <sub>H</sub> to 003BFF <sub>H</sub>	(Reserved area) *				
003C00 <sub>H</sub> to 003C0F <sub>H</sub>	RAM (General-purpose RAM)				

(Continued)

# MB90385 Series

Address	Register abbreviation	Register	Read/Write	Resource	Initial value
003C10 <sub>H</sub> to 003C13 <sub>H</sub>	IDR0	ID register 0	R/W	CAN controller	XXXXXXXX <sub>B</sub> to XXXXXXXX <sub>B</sub>
003C14 <sub>H</sub> to 003C17 <sub>H</sub>	IDR1	ID register 1	R/W		XXXXXXXX <sub>B</sub> to XXXXXXXX <sub>B</sub>
003C18 <sub>H</sub> to 003C1B <sub>H</sub>	IDR2	ID register 2	R/W		XXXXXXXX <sub>B</sub> to XXXXXXXX <sub>B</sub>
003C1C <sub>H</sub> to 003C1F <sub>H</sub>	IDR3	ID register 3	R/W		XXXXXXXX <sub>B</sub> to XXXXXXXX <sub>B</sub>
003C20 <sub>H</sub> to 003C23 <sub>H</sub>	IDR4	ID register 4	R/W		XXXXXXXX <sub>B</sub> to XXXXXXXX <sub>B</sub>
003C24 <sub>H</sub> to 003C27 <sub>H</sub>	IDR5	ID register 5	R/W		XXXXXXXX <sub>B</sub> to XXXXXXXX <sub>B</sub>
003C28 <sub>H</sub> to 003C2B <sub>H</sub>	IDR6	ID register 6	R/W		XXXXXXXX <sub>B</sub> to XXXXXXXX <sub>B</sub>
003C2C <sub>H</sub> to 003C2F <sub>H</sub>	IDR7	ID register 7	R/W		XXXXXXXX <sub>B</sub> to XXXXXXXX <sub>B</sub>
003C30 <sub>H</sub> 003C31 <sub>H</sub>	DLCR0	DLC register 0	R/W		XXXXXXXX <sub>B</sub> XXXXXXXX <sub>B</sub>
003C32 <sub>H</sub> 003C33 <sub>H</sub>	DLCR1	DLC register 1	R/W		XXXXXXXX <sub>B</sub> XXXXXXXX <sub>B</sub>
003C34 <sub>H</sub> 003C35 <sub>H</sub>	DLCR2	DLC register 2	R/W		XXXXXXXX <sub>B</sub> XXXXXXXX <sub>B</sub>
003C36 <sub>H</sub> 003C37 <sub>H</sub>	DLCR3	DLC register 3	R/W		XXXXXXXX <sub>B</sub> XXXXXXXX <sub>B</sub>
003C38 <sub>H</sub> 003C39 <sub>H</sub>	DLCR4	DLC register 4	R/W		XXXXXXXX <sub>B</sub> XXXXXXXX <sub>B</sub>
003C3A <sub>H</sub> 003C3B <sub>H</sub>	DLCR5	DLC register 5	R/W		XXXXXXXX <sub>B</sub> XXXXXXXX <sub>B</sub>

(Continued)

# MB90385 Series

Address	Register abbreviation	Register	Read/Write	Resource	Initial value
003C3C <sub>H</sub> 003C3D <sub>H</sub>	DLCR6	DLC register 6	R/W	CAN controller	XXXXXXXX <sub>B</sub> XXXXXXXX <sub>B</sub>
003C3E <sub>H</sub> 003C3F <sub>H</sub>	DLCR7	DLC register 7	R/W		XXXXXXXX <sub>B</sub> XXXXXXXX <sub>B</sub>
003C40 <sub>H</sub> to 003C47 <sub>H</sub>	DTR0	Data register 0	R/W		XXXXXXXX <sub>B</sub> to XXXXXXXX <sub>B</sub>
003C48 <sub>H</sub> to 003C4F <sub>H</sub>	DTR1	Data register 1	R/W		XXXXXXXX <sub>B</sub> to XXXXXXXX <sub>B</sub>
003C50 <sub>H</sub> to 003C57 <sub>H</sub>	DTR2	Data register 2	R/W		XXXXXXXX <sub>B</sub> to XXXXXXXX <sub>B</sub>
003C58 <sub>H</sub> to 003C5F <sub>H</sub>	DTR3	Data register 3	R/W		XXXXXXXX <sub>B</sub> to XXXXXXXX <sub>B</sub>
003C60 <sub>H</sub> to 003C67 <sub>H</sub>	DTR4	Data register 4	R/W		XXXXXXXX <sub>B</sub> to XXXXXXXX <sub>B</sub>
003C68 <sub>H</sub> to 003C6F <sub>H</sub>	DTR5	Data register 5	R/W		XXXXXXXX <sub>B</sub> to XXXXXXXX <sub>B</sub>
003C70 <sub>H</sub> to 003C77 <sub>H</sub>	DTR6	Data register 6	R/W		XXXXXXXX <sub>B</sub> to XXXXXXXX <sub>B</sub>
003C78 <sub>H</sub> to 003C7F <sub>H</sub>	DTR7	Data register 7	R/W		XXXXXXXX <sub>B</sub> to XXXXXXXX <sub>B</sub>
003C80 <sub>H</sub> to 003CFF <sub>H</sub>	(Reserved area) *				
003D00 <sub>H</sub> 003D01 <sub>H</sub>	CSR	Control status register	R/W, R	CAN controller	0XXXX001 <sub>B</sub> 00XXX000 <sub>B</sub>
003D02 <sub>H</sub>	LEIR	Last event display register	R/W		000XX000 <sub>B</sub>
003D03 <sub>H</sub>	(Reserved area) *				
003D04 <sub>H</sub> 003D05 <sub>H</sub>	RTEC	Send/receive error counter	R	CAN controller	00000000 <sub>B</sub> 00000000 <sub>B</sub>
003D06 <sub>H</sub> 003D07 <sub>H</sub>	BTR	Bit timing register	R/W		11111111 <sub>B</sub> X1111111 <sub>B</sub>
003D08 <sub>H</sub>	IDER	IDE register	R/W		XXXXXXXX <sub>B</sub>
003D09 <sub>H</sub>	(Reserved area) *				
003D0A <sub>H</sub>	TRTRR	Send RTR register	R/W	CAN controller	00000000 <sub>B</sub>

(Continued)

# MB90385 Series

(Continued)

Address	Register abbreviation	Register	Read/Write	Resource	Initial value
003D0B <sub>H</sub>	(Reserved area) *				
003D0C <sub>H</sub>	RFWTR	Remote frame receive wait register	R/W	CAN controller	XXXXXXXX <sub>B</sub>
003D0D <sub>H</sub>	(Reserved area) *				
003D0E <sub>H</sub>	TIER	Send completion interrupt permission register	R/W	CAN controller	00000000 <sub>B</sub>
003D0F <sub>H</sub>	(Reserved area) *				
003D10 <sub>H</sub> 003D11 <sub>H</sub>	AMSR	Acceptance mask selection register	R/W	CAN controller	XXXXXXXX <sub>B</sub> XXXXXXXX <sub>B</sub>
003D12 <sub>H</sub> 003D13 <sub>H</sub>	(Reserved area) *				
003D14 <sub>H</sub> to 003D17 <sub>H</sub>	AMR0	Acceptance mask register 0	R/W	CAN controller	XXXXXXXX <sub>B</sub> to XXXXXXXX <sub>B</sub>
003D18 <sub>H</sub> to 003D1B <sub>H</sub>	AMR1	Acceptance mask register 1	R/W		XXXXXXXX <sub>B</sub> to XXXXXXXX <sub>B</sub>
003D1C <sub>H</sub> to 003DFF <sub>H</sub>	(Reserved area) *				
003E00 <sub>H</sub> to 003EFF <sub>H</sub>	(Reserved area) *				
003FF0 <sub>H</sub> to 003FFF <sub>H</sub>	(Reserved area) *				

Initial values :

0 : Initial value of this bit is "0."

1 : Initial value of this bit is "1."

X : Initial value of this bit is undefined.

\* : "Reserved area" should not be written anything. Result of reading from "Reserved area" is undefined.

## ■ INTERRUPT SOURCES, INTERRUPT VECTORS, AND INTERRUPT CONTROL REGISTERS

Interrupt source	E <sup>POS</sup> readiness	Interrupt vector		Interrupt control register		Priority* <sup>3</sup>	
		Number	Address	ICR	Address		
Reset	×	#08	08 <sub>H</sub>	FFFFDC <sub>H</sub>	—	—	High ↑
INT 9 instruction	×	#09	09 <sub>H</sub>	FFFFD8 <sub>H</sub>	—	—	
Exceptional treatment	×	#10	0A <sub>H</sub>	FFFFD4 <sub>H</sub>	—	—	
CAN controller reception completed (RX)	×	#11	0B <sub>H</sub>	FFFFD0 <sub>H</sub>	ICR00	0000B0 <sub>H</sub> * <sup>1</sup>	
CAN controller transmission completed (TX) / Node status transition (NS)	×	#12	0C <sub>H</sub>	FFFFCC <sub>H</sub>			
Reserved	×	#13	0D <sub>H</sub>	FFFFC8 <sub>H</sub>	ICR01	0000B1 <sub>H</sub>	
Reserved	×	#14	0E <sub>H</sub>	FFFFC4 <sub>H</sub>			
CAN wakeup	Δ	#15	0F <sub>H</sub>	FFFFC0 <sub>H</sub>	ICR02	0000B2 <sub>H</sub> * <sup>1</sup>	
Time-base timer	×	#16	10 <sub>H</sub>	FFFFBC <sub>H</sub>			
16-bit reload timer 0	Δ	#17	11 <sub>H</sub>	FFFFB8 <sub>H</sub>	ICR03	0000B3 <sub>H</sub> * <sup>1</sup>	
8/10-bit A/D converter	Δ	#18	12 <sub>H</sub>	FFFFB4 <sub>H</sub>			
16-bit free-run timer overflow	Δ	#19	13 <sub>H</sub>	FFFFB0 <sub>H</sub>	ICR04	0000B4 <sub>H</sub> * <sup>1</sup>	
Reserved	×	#20	14 <sub>H</sub>	FFFFAC <sub>H</sub>			
Reserved	×	#21	15 <sub>H</sub>	FFFFA8 <sub>H</sub>	ICR05	0000B5 <sub>H</sub> * <sup>2</sup>	
PPG timer ch0, ch1 underflow	×	#22	16 <sub>H</sub>	FFFFA4 <sub>H</sub>			
Input capture 0-input	Δ	#23	17 <sub>H</sub>	FFFFA0 <sub>H</sub>	ICR06	0000B6 <sub>H</sub> * <sup>1</sup>	
External interrupt (INT4/INT5)	Δ	#24	18 <sub>H</sub>	FFFF9C <sub>H</sub>			
Input capture 1-input	Δ	#25	19 <sub>H</sub>	FFFF98 <sub>H</sub>	ICR07	0000B7 <sub>H</sub> * <sup>1</sup>	
PPG timer ch2, ch3 underflow	×	#26	1A <sub>H</sub>	FFFF94 <sub>H</sub>			
External interrupt (INT6/INT7)	Δ	#27	1B <sub>H</sub>	FFFF90 <sub>H</sub>	ICR08	0000B8 <sub>H</sub> * <sup>1</sup>	
Clock timer	Δ	#28	1C <sub>H</sub>	FFFF8C <sub>H</sub>			
Reserved	×	#29	1D <sub>H</sub>	FFFF88 <sub>H</sub>	ICR09	0000B9 <sub>H</sub> * <sup>1</sup>	
Input capture 2-input Input capture 3-input	×	#30	1E <sub>H</sub>	FFFF84 <sub>H</sub>			
Reserved	×	#31	1F <sub>H</sub>	FFFF80 <sub>H</sub>	ICR10	0000BA <sub>H</sub> * <sup>1</sup>	
Reserved	×	#32	20 <sub>H</sub>	FFFF7C <sub>H</sub>			
Reserved	×	#33	21 <sub>H</sub>	FFFF78 <sub>H</sub>	ICR11	0000BB <sub>H</sub> * <sup>1</sup>	
Reserved	×	#34	22 <sub>H</sub>	FFFF74 <sub>H</sub>			
Reserved	×	#35	23 <sub>H</sub>	FFFF70 <sub>H</sub>	ICR12	0000BC <sub>H</sub> * <sup>1</sup>	↓ Low
16-bit reload timer 1	○	#36	24 <sub>H</sub>	FFFF6C <sub>H</sub>			

(Continued)

# MB90385 Series

(Continued)

Interrupt source	EI <sup>2</sup> OS readiness	Interrupt vector			Interrupt control register		Priority* <sup>3</sup>
		Number		Address	ICR	Address	
UART1 reception completed	○	#37	25 <sub>H</sub>	FFFF68 <sub>H</sub>	ICR13	0000BD <sub>H</sub> * <sup>1</sup>	High ↑
UART1 transmission completed	Δ	#38	26 <sub>H</sub>	FFFF64 <sub>H</sub>			
Reserved	×	#39	27 <sub>H</sub>	FFFF60 <sub>H</sub>	ICR14	0000BE <sub>H</sub> * <sup>1</sup>	
Reserved	×	#40	28 <sub>H</sub>	FFFF5C <sub>H</sub>			
Flash memory	×	#41	29 <sub>H</sub>	FFFF58 <sub>H</sub>	ICR15	0000BF <sub>H</sub> * <sup>1</sup>	↓ Low
Delay interrupt generation module	×	#42	2A <sub>H</sub>	FFFF54 <sub>H</sub>			

○ : Available

×

○ : Available EI<sup>2</sup>OS function is provided.

Δ : Available when a cause of interrupt sharing a same ICR is not used.

\*1 : • Peripheral functions sharing an ICR register have the same interrupt level.

• If peripheral functions share an ICR register, only one function is available when using expanded intelligent I/O service.

• If peripheral functions share an ICR register, a function using expanded intelligent I/O service does not allow interrupt by another function.

\*2 : Only 16-bit reload timer is ready for EI<sup>2</sup>OS. Because PPG is not ready for EI<sup>2</sup>OS, disable PPG interrupt when using EI<sup>2</sup>OS with 16-bit reload timer.

\*3 : Priority when two or more interrupts of a same level occur simultaneously.

## ■ PERIPHERAL RESOURCES

### 1. I/O Ports

The I/O ports are used as general-purpose input/output ports (parallel I/O ports). The MB60385 series model is provided with 5 ports (34 inputs). The ports function as input/output pins for peripheral functions also.

#### • I/O port functions

An I/O port, using port data register (PDR), outputs the output data to I/O pin and input a signal input to I/O port. The port direction register (DDR) specifies direction of input/output of I/O pins on a bit-by-bit basis.

The following summarizes functions of the ports and sharing peripheral functions :

- Port 1 : General-purpose input/output port, used also for PPG timer output and input capture inputs.
- Port 2 : General-purpose input/output port, used also for reload timer input/output and external interrupt input.
- Port 3 : General-purpose input/output port, used also for A/D converter activation trigger pin.
- Port 4 : General-purpose input/output port, used also for UART input/output and CAN controller send/receive pin.
- Port 5 : General-purpose input/output port, used also analog input pin.

#### • Port 1 pins block diagram (single-chip mode)

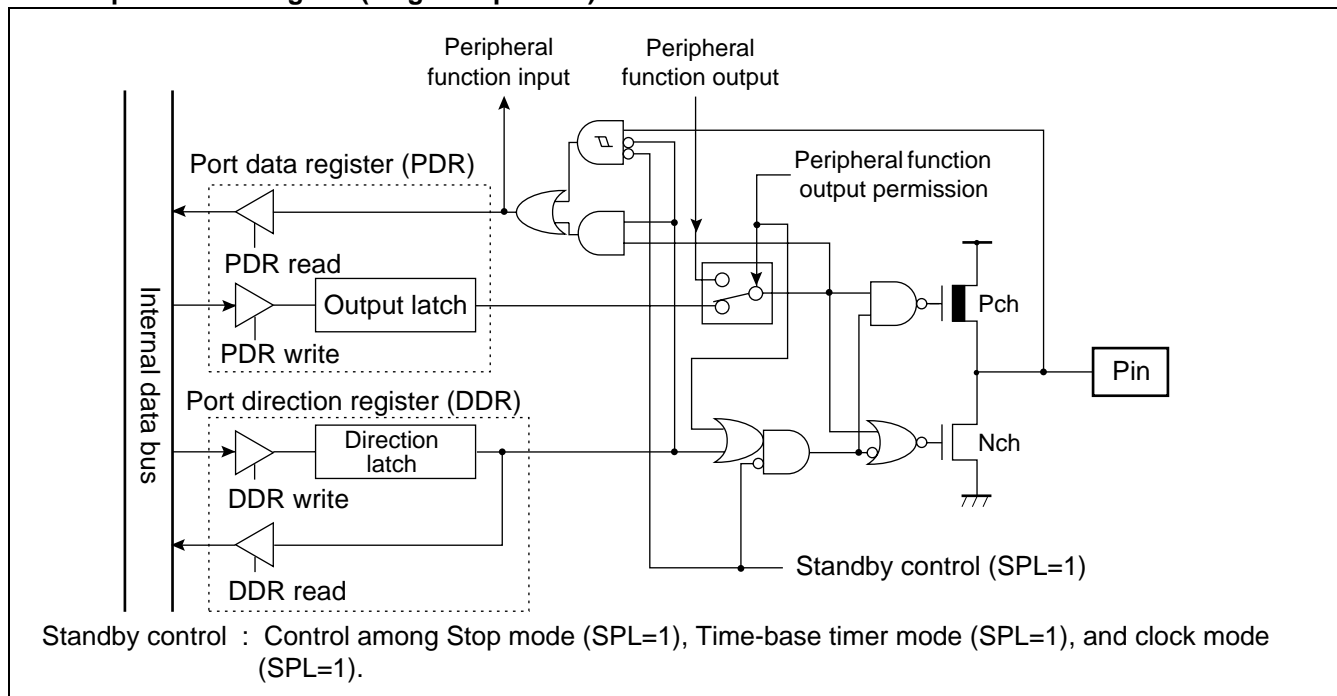

#### • Port 1 registers (single-chip mode)

- Port 1 registers include port 1 data register (PDR1) and port 1 direction register (DDR1).
- The bits configuring the register correspond to port 1 pins on a one-to-one basis.

#### Relation between port 1 registers and pins

Port name	Bits of register and corresponding pins								
Port 1	PDR1, DDR1	bit7	bit6	bit5	bit4	bit3	bit2	bit1	bit0
	Corresponding pins	P17	P16	P15	P14	P13	P12	P11	P10

# MB90385 Series

## • Port 2 pins block diagram (general-purpose input/output port)

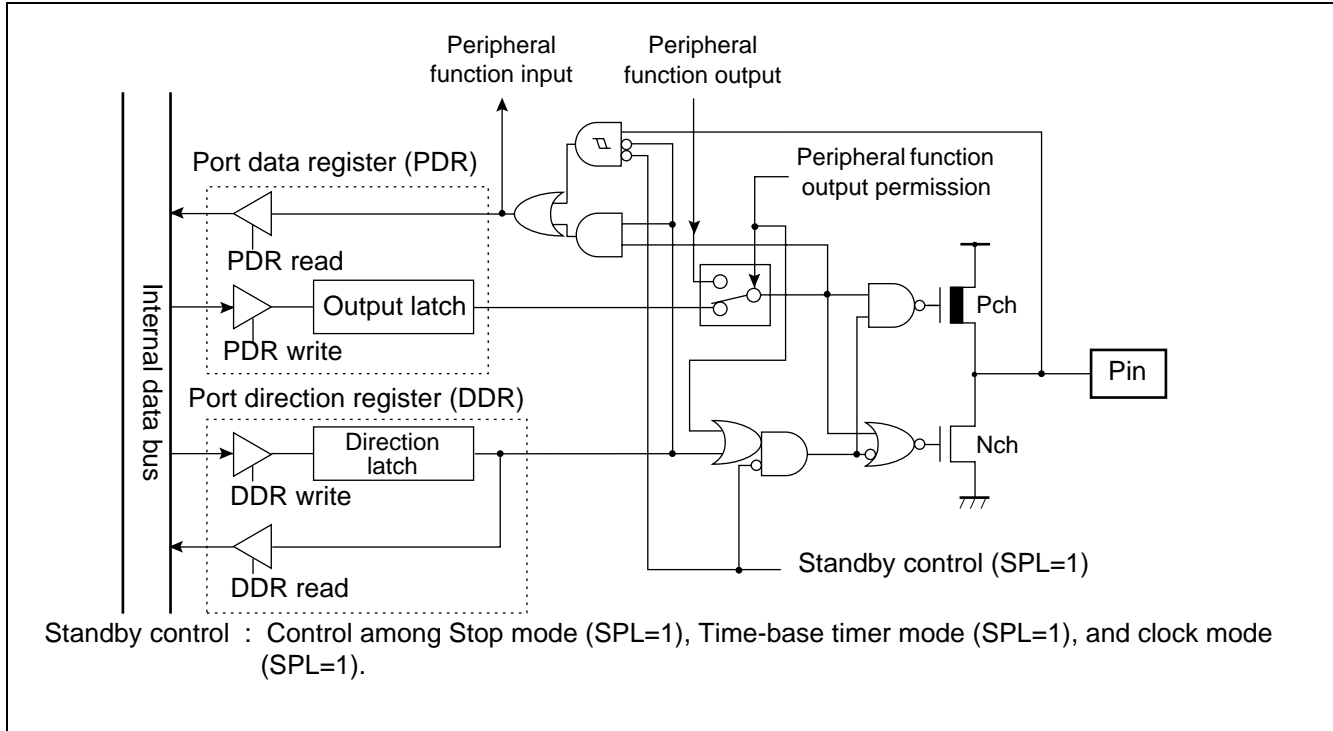

## • Port 2 registers

- Port 2 registers include port 2 data register (PDR2) and port 2 direction register (DDR2).
- The bits configuring the register correspond to port 2 pins on a one-to-one basis.

### Relation between port 2 registers and pins

Port name	Bits of register and corresponding pins								
	PDR2,DDR2	bit7	bit6	bit5	bit4	bit3	bit2	bit1	bit0
Port 2	Corresponding pins	P27	P26	P25	P24	P23	P22	P21	P20

## • Port 3 pins block diagram (general-purpose input/output port)

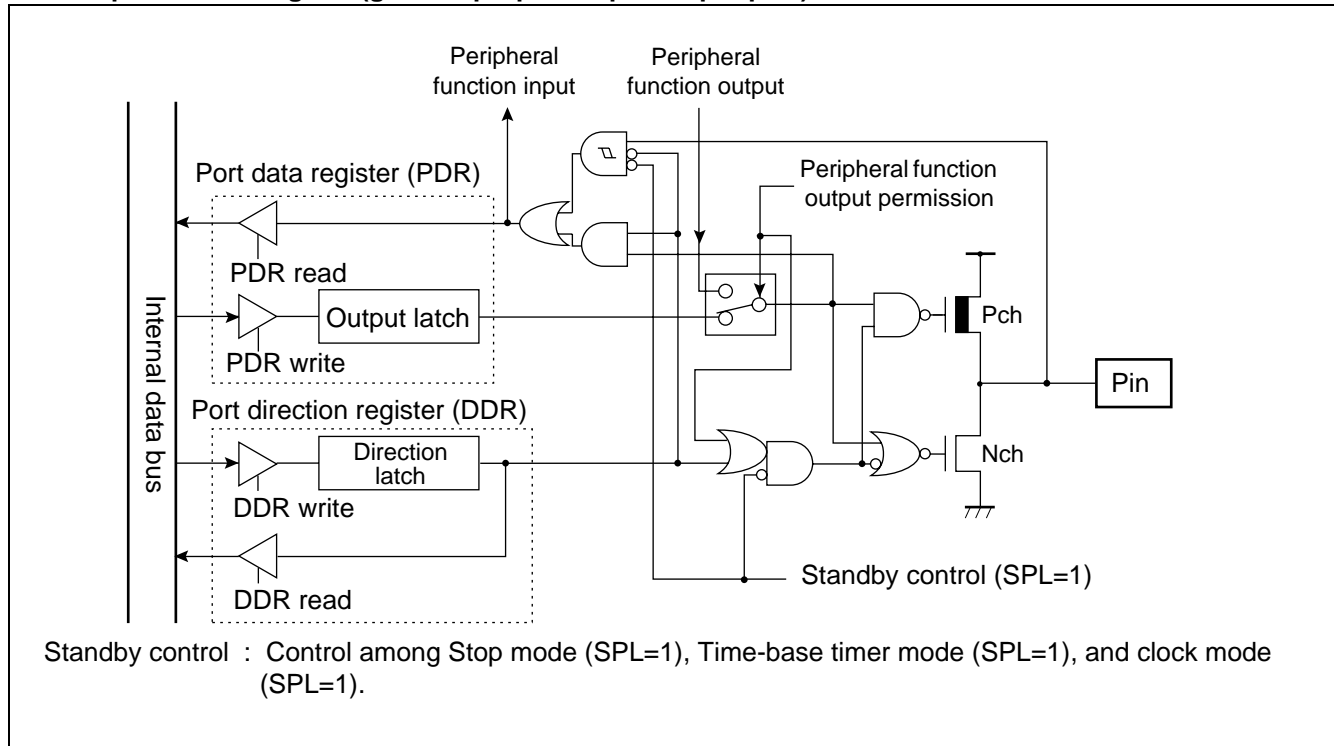

## • Port 3 registers

- Port 3 registers include port 3 data register (PDR3) and port 3 direction register (DDR3).
- The bits configuring the register correspond to port 3 pins on a one-to-one basis.

### Relation between port 3 registers and pins

Port name	Bits of register and corresponding pins								
	PDR3, DDR3	bit7	bit6	bit5	bit4	bit3	bit2	bit1	bit0
Port 3	Corresponding pins	P37	P36*	P35*	—	P33	P32	P31	P30

\* : P35 and P36 do not exist on MB90387 and MB90F387.

# MB90385 Series

## • Port 4 pins block diagram

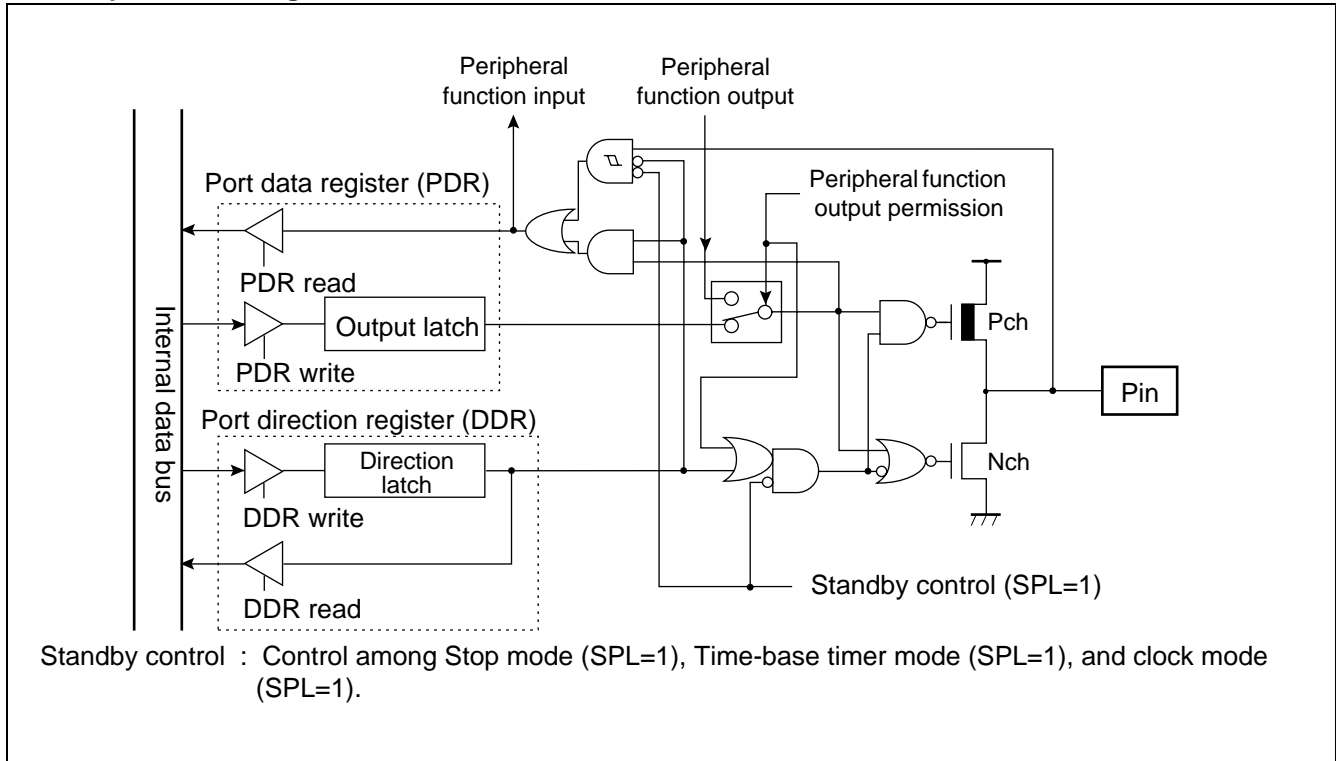

## • Port 4 registers

- Port 4 registers include port 4 data register (PDR4) and port 4 direction register (DDR4).
- The bits configuring the register correspond to port 4 pins on a one-to-one basis.

## Relation between port 4 registers and pins

Port name	Bits of register and corresponding pins								
Port 4	PDR4, DDR4	—	—	—	bit4	bit3	bit2	bit1	bit0
	Corresponding pins	—	—	—	P44	P43	P42	P41	P40

## • Port 5 pins block diagram

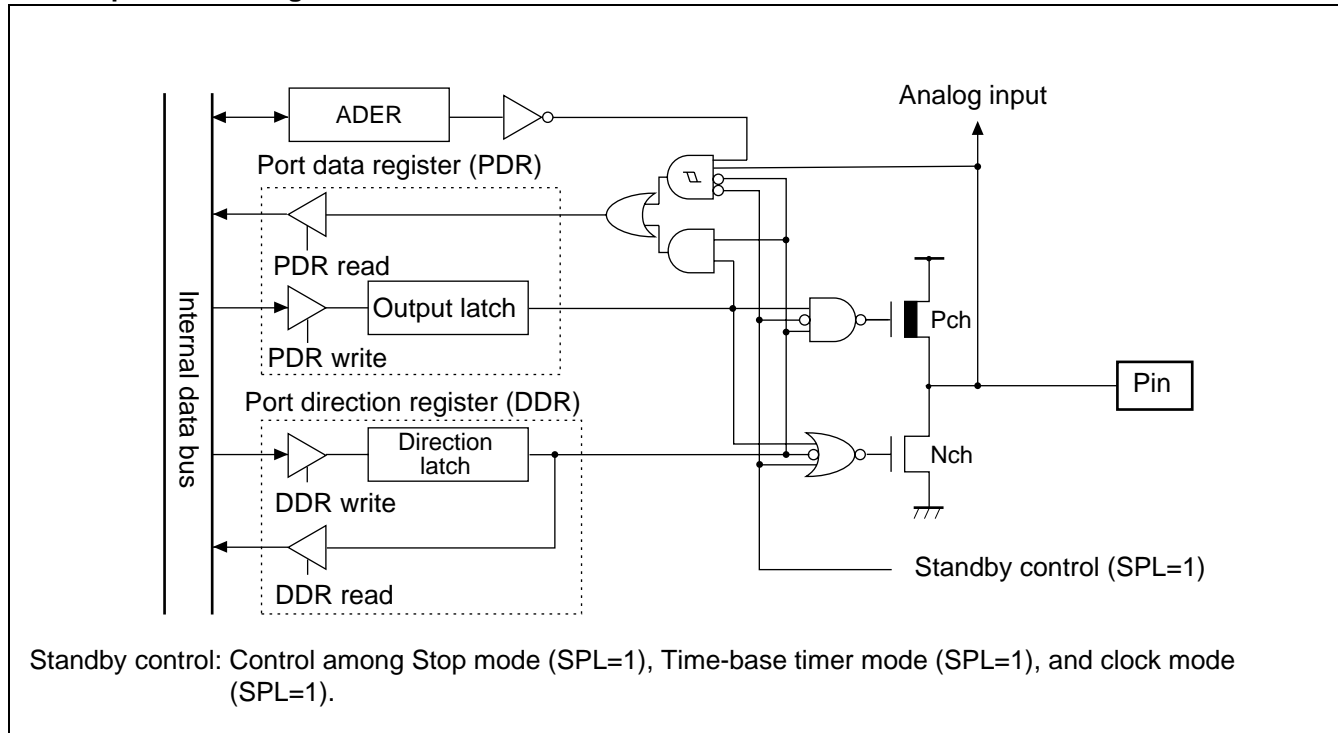

## • Port 5 registers

- Port 5 registers include port 5 data register (PDR5), port 5 direction register (DDR5), and analog input permission register (ADER).
- Analog input permission register (ADER) allows or disallows input of analog signal to the analog input pin.
- The bits configuring the register correspond to port 5 pins on a one-to-one basis.

## Relation between port 5 registers and pins

Port name	Bits of register and corresponding pins								
	PDR5, DDR5	bit7	bit6	bit5	bit4	bit3	bit2	bit1	bit0
Port 5	ADER	ADE7	ADE6	ADE5	ADE4	ADE3	ADE2	ADE1	ADE0
	Corresponding pins	P57	P56	P55	P54	P53	P52	P51	P50

## 2. Time-Base Timer

The time-base timer is an 18-bit free-run counter (time-base timer counter) that counts up in synchronization with the main clock (dividing main oscillation clock by 2).

- Four choices of interval time are selectable, and generation of interrupt request is allowed for each interval time.
- Provides operation clock signal to oscillation stabilizing wait timer and peripheral functions.

### • Interval timer function

- When the counter of time-base timer reaches an interval time specified by interval time selection bit (TBTC:TBC1, TBC0), an overflow (carrying-over) occurs (TBTC: TBOF=1) and interrupt request is generated.
- If an interrupt by overflow is permitted (TBTC: TBIE=1), an interrupt is generated when overflow occurs (TBTC: TBOF=1).
- The following four interval time settings are selectable :

### Interval time of time-base timer

Count clock	Interval time
2/HCLK (0.5 $\mu$ s)	$2^{12}$ /HCLK (Approx. 1.0 ms)
	$2^{14}$ /HCLK (Approx. 4.1 ms)
	$2^{16}$ /HCLK (Approx. 16.4 ms)
	$2^{19}$ /HCLK (Approx. 131.1 ms)

HCLK: Oscillation clock

Values in parentheses “( )” are those under operation of 4-MHz oscillation clock.

## • Time-base timer block diagram

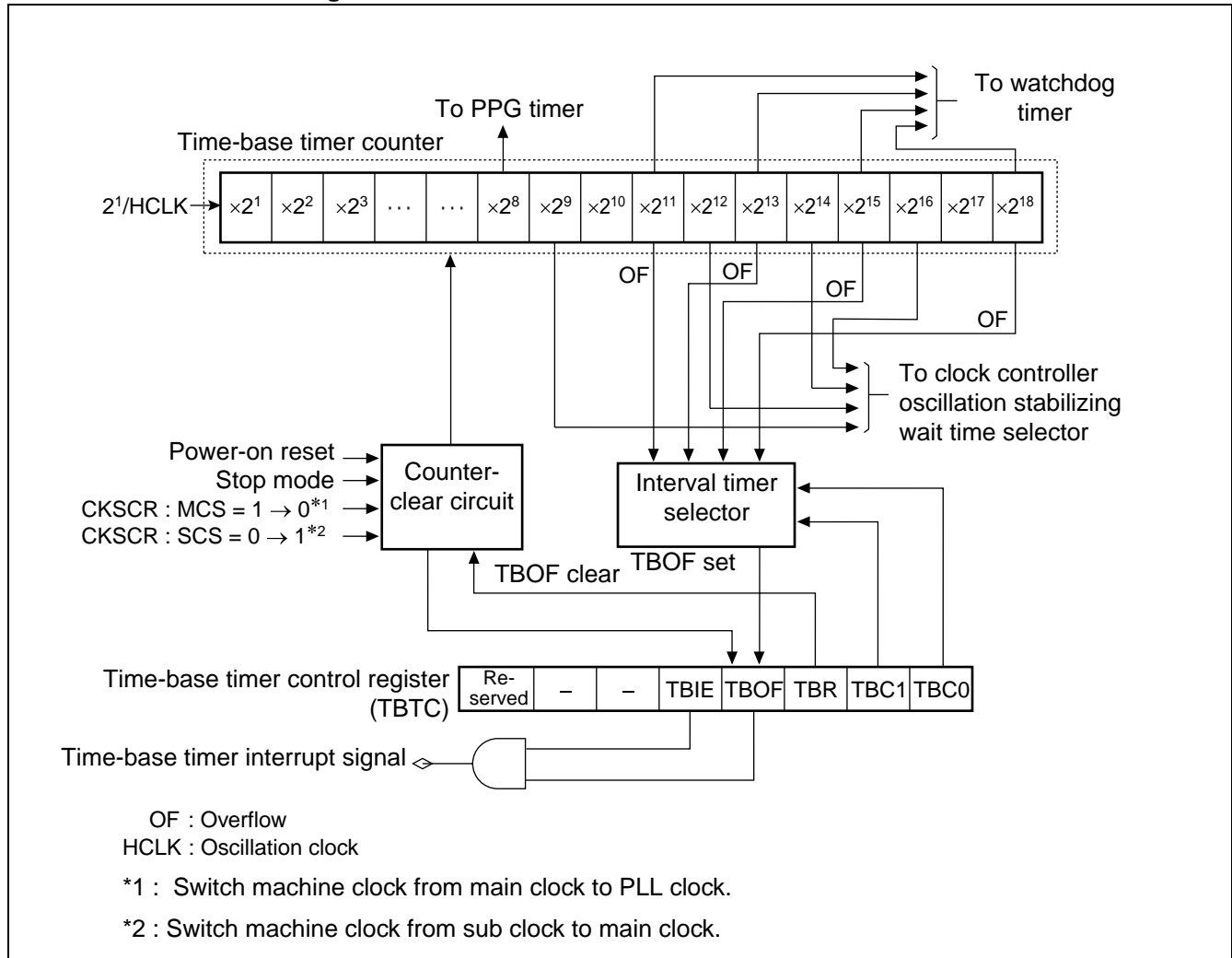

Actual interrupt request number of time-base timer is as follows:

Interrupt request number: #16 (10<sub>H</sub>)

# MB90385 Series

## 3. Watchdog Timer

The watchdog timer is a 2-bit counter that uses time-base timer or clock timer as count clock. If the counter is not cleared within an interval time, CPU is reset.

### •Watchdog timer functions

- The watchdog timer is a timer counter that prevents runaway of a program. Once a watchdog timer is activated, the counter of watchdog timer must always be cleared within a specified time of interval. If specified interval time elapses without clearing the counter of a watchdog timer, CPU resetting occurs. This is the function of a watchdog timer.
- The interval time of a watchdog timer is determined by a clock cycle, which is input as a count clock. Watchdog resetting occurs between a minimum time and a maximum time specified.
- The output target of a clock source is specified by the watchdog clock selection bit (WTC: WDCS) in the clock timer control register.
- Interval time of a watchdog timer is specified by the time-base timer output selection bit/clock timer output selection bit (WDTC: WT1, WT0) in the watchdog timer control register.

### Interval timer of watchdog timer

Min	Max	Clock cycle	Min	Max	Clock cycle
Approx. 3.58 ms	Approx. 4.61 ms	$2^{14} \pm 2^{11}$ /HCLK	Approx. 0.457 s	Approx. 0.576 s	$2^{12} \pm 2^9$ /SCLK
Approx. 14.33 ms	Approx. 18.3 ms	$2^{16} \pm 2^{13}$ /HCLK	Approx. 3.584 s	Approx. 4.608 s	$2^{15} \pm 2^{12}$ /SCLK
Approx. 57.23 ms	Approx. 73.73 ms	$2^{18} \pm 2^{15}$ /HCLK	Approx. 7.168 s	Approx. 9.216 s	$2^{16} \pm 2^{13}$ /SCLK
Approx. 458.75 ms	Approx. 589.82 ms	$2^{21} \pm 2^{18}$ /HCLK	Approx. 14.336 s	Approx. 18.432 s	$2^{17} \pm 2^{14}$ /SCLK

HCLK: Oscillation clock ( 4 MHz) , CSCLK: Sub clock (8.192 kHz)

- Notes:
- If the time-base timer is cleared when watchdog timer count clock is used as time base timer output (carry-over signal), watchdog reset time may become longer.
  - When using the sub clock as machine clock, be sure to specify watchdog timer clock source selection bit (WDCS) in clock timer control register (WTC) at "0," selecting output of clock timer.

• Watchdog timer block diagram

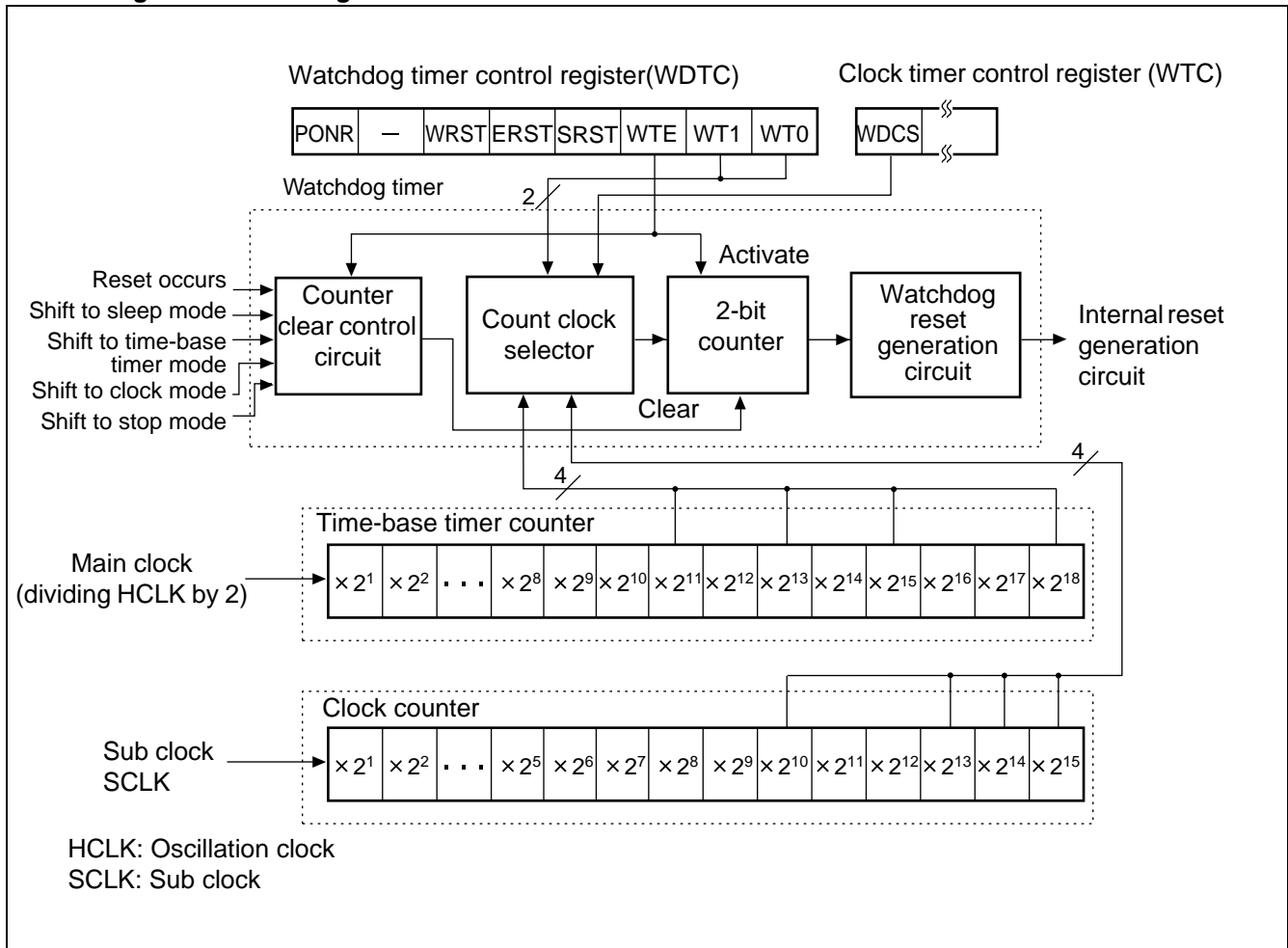

## 4. 16-bit Input/Output Timer

The 16-bit input/output timer is a compound module composed of 16-bit free-run timer, (1 unit) and input capture (2 units, 4 input pins). The timer, using the 16-bit free-run timer as a basis, enables measurement of clock cycle of an input signal and its pulse width.

### • Configuration of 16-bit input/output timer

The 16-bit input/output timer is composed of the following modules:

- 16-bit free-run timer (1 unit)
- Input capture (2 units, 2 input pins per unit)

### • Functions of 16-bit input/output timer

#### (1) Functions of 16-bit free-run timer

The 16-bit free-run timer is composed of 16-bit up counter, timer counter control status register, and prescaler. The 16-bit up counter increments in synchronization with dividing ratio of machine clock.

- Count clock is set among four types of machine clock dividing rates.
- Generation of interrupt is allowed by counter value overflow.
- Activation of expanded intelligent I/O service (EI<sup>2</sup>OS) is allowed by interrupt generation.
- Counter value of 16-bit free-run timer is cleared to “0000H” by either resetting or software-clearing with timer count clear bit (TCCS: CLR).
- Counter value of 16-bit free-run timer is output to input capture, which is available as base time for capture operation.

#### (2) Functions of input capture

The input capture, upon detecting an edge of a signal input to the input pin from external device, stores a counter value of 16-bit free-run timer at the time of detection into the input capture data register. The function includes the input capture data registers corresponding to four input pins, input capture control status register, and edge detection circuit.

- Rising edge, falling edge, and both edges are selectable for detection.
- Generating interrupt on CPU is allowed by detecting an edge of input signal.
- Expanded intelligent I/O service (EI<sup>2</sup>OS) is activated by interrupt generation.
- The four input capture input pins and input capture data registers allows monitoring of a maximum of four events.

## • 16-bit input/output timer block diagram

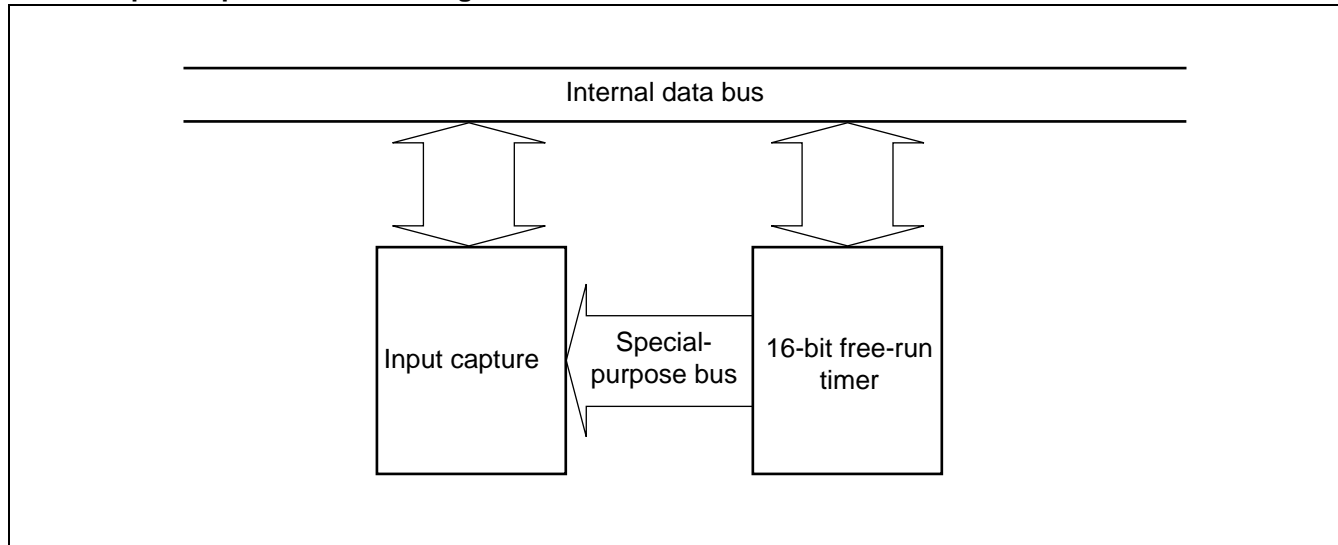

## • 16-bit free-run timer

Counter value of 16-bit free-run timer is used as reference time (base time) of input capture.

## • Input capture

Input capture detects rising edge, falling edge or both edges and retains a counter value of 16-bit free-run timer. Detection of edge on input signal is allowed to generate interrupt.

## • 16-bit free-run timer block diagram

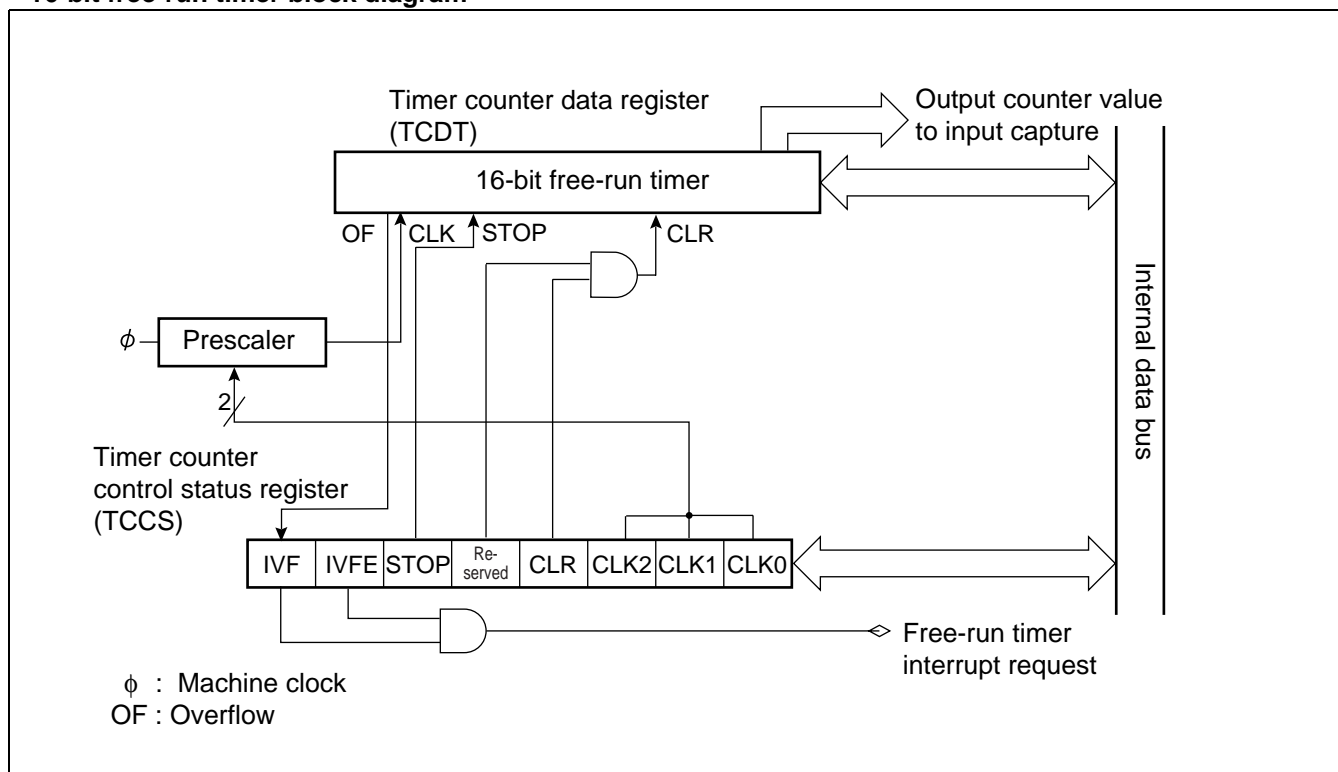

# MB90385 Series

- **Detailed pin assignment on block diagram**

The 16-bit input/output timer includes a 16-bit free-run timer. Interrupt request number of the 16-bit free-run timer is as follows:

Interrupt request number: 19 (13<sub>H</sub>)

- **Prescaler**

The prescaler divides a machine clock and provides a counter clock to the 16-bit up counter. Dividing ratio of the machine clock is specified by timer counter control status register (TCCS) among four values.

- **Timer counter data register (TCDT)**

The timer counter data register is a 16-bit up counter. A current counter value of the 16-bit free-run timer is read. Writing a value during halt of the counter allows setting an arbitrary counter value.

## •Input capture block diagram

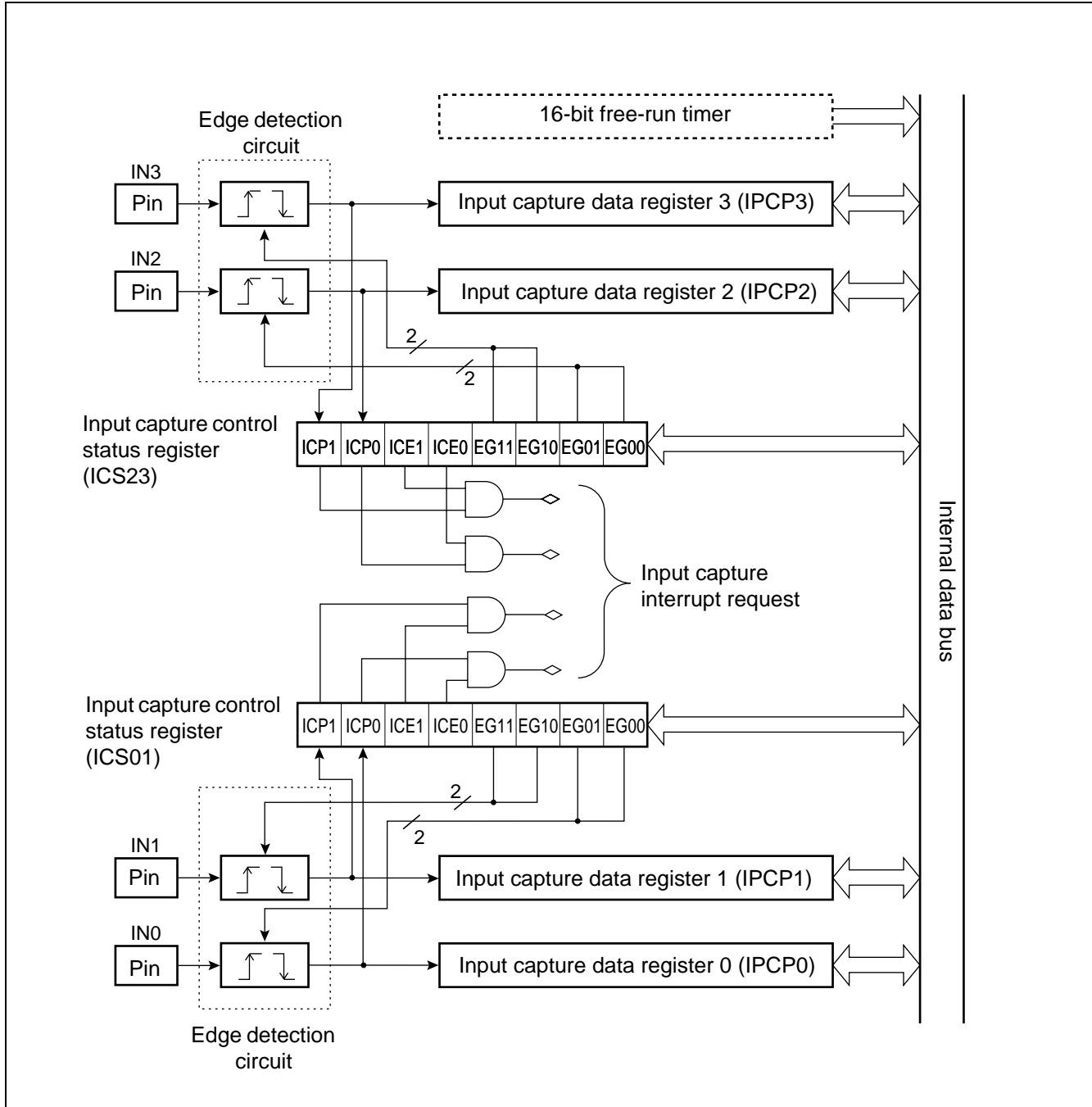

## 5. 16-bit Reload Timer

The 16-bit reload timer has the following functions:

- Count clock is selectable among 3 internal clocks and external event clock.
- Activation trigger is selectable between software trigger and external trigger.
- Generation of CPU interrupt is allowed upon occurrence of underflow on 16-bit timer register. Available as an interval timer using the interrupt function.
- When underflow of 16-bit timer register (TMR) occurs, one of two reload modes is selectable between one-shot mode that halts counting operation of TMR, and reload mode that reloads 16-bit reload register value to TMR, continuing TMR counting operation.
- The 16-bit reload timer is ready for expanded intelligent I/O service (EI<sup>2</sup>OS).
- MB90385 series device has 2 channels of built-in 16-bit reload timer.

### • Operation mode of 16-bit reload timer

Count clock	Activation trigger	Operation upon underflow
Internal clock mode	Software trigger, external trigger	One-shot mode, reload mode
Event count mode	Software trigger	One-shot mode, reload mode

### • Internal clock mode

- The 16-bit reload timer is set to internal clock mode, by setting count clock selection bit (TMCSR: CSL1, CSL0) to "00<sub>B</sub>", "01<sub>B</sub>", "10<sub>B</sub>".
- In the internal clock mode, the counter decrements in synchronization with the internal clock.
- Three types of count clock cycles are selectable by count clock selection bit (TMCSR: CSL1, CSL0) in timer control status register.
- Edge detection of software trigger or external trigger is specified as an activation trigger.



# MB90385 Series

## 6. Clock Timer Outline

The clock timer is a 15-bit free-run counter that increments in synchronization with sub clock.

- Interval time is selectable among 7 choices, and generation of interrupt request is allowed for each interval.
- Provides operation clock to the subclock oscillation stabilizing wait timer and watchdog timer.
- Always uses subclock as a count clock regardless of settings of clock selection register (CKSCR).

### • Interval timer function

- In the clock timer, a bit corresponding to the interval time overflows (carry-over) when an interval time, which is specified by interval time selection bit, is reached. Then overflow flag bit is set (WTC: WTOF=1).
- If an interrupt by overflow is permitted (WTC: WTIE=1), an interrupt request is generated upon setting an overflow flag bit.
- Interval time of clock timer is selectable among the following seven choices :

### • Interval time of clock timer

Sub clock cycle	Interval time
SCLK (122 $\mu$ s)	$2^8$ /SCLK (31.25 ms)
	$2^9$ /SCLK (62.5 ms)
	$2^{10}$ /SCLK (125 ms)
	$2^{11}$ /SCLK (250 ms)
	$2^{12}$ /SCLK (500 ms)
	$2^{13}$ /SCLK (1.0 s)
	$2^{14}$ /SCLK (2.0 s)

SCLK: Sub clock frequency

Values in parentheses “( )” are calculation when operating with 8.192 kHz clock.

## • Clock timer block diagram

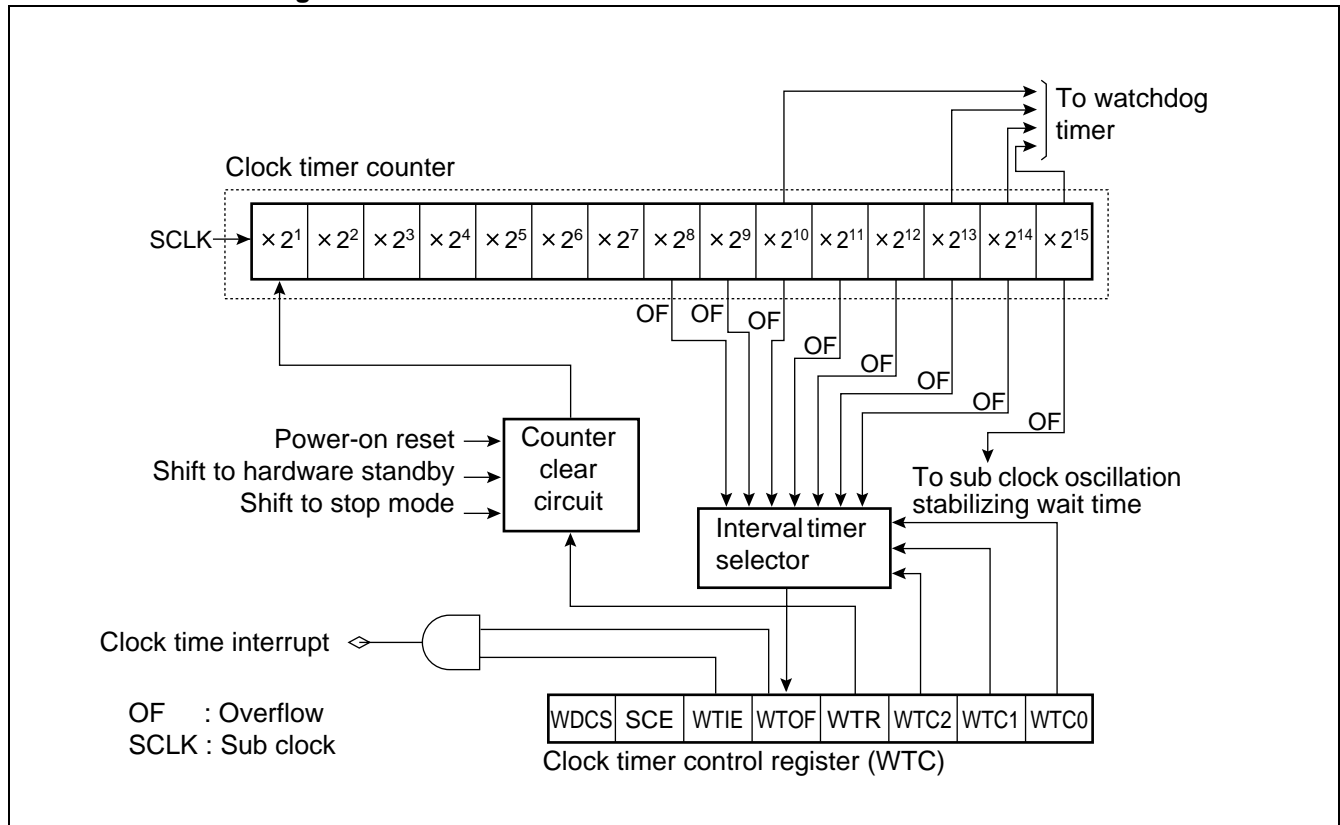

Actual interrupt request number of clock timer is as follows :

Interrupt request number : #28 (1C<sub>H</sub>)

## • Clock timer counter

A 15-bit up counter that uses sub clock (SCLK) as a count clock.

## • Counter clear circuit

A circuit that clears the clock timer counter.

## 7. 8/16-bit PPG Timer Outline

The 8/16-bit PPG timer is a 2-channel reload timer module (PPG0 and PPG1) that allows outputting pulses of arbitrary cycle and duty cycle. Combination of the two channels allows selection among the following operations:

- 8-bit PPG output 2-channel independent operation mode
- 16-bit PPG output operation mode
- 8-bit and 8-bit PPG output operation mode

MB90385 series device has two 8/16-bit built-in PPG timers. This section describes functions of PPG0/1. PPG2/3 have the same functions as those of PPG0/1.

### • Functions of 8/16-bit PPG timer

The 8/16-bit PPG timer is composed of four 8-bit reload register (PRLH0/PRL0, PRLH1/PRL1) and two PPG down counters (PCNT0, PCNT1).

- Widths of "H" and "L" in output pulse are specifiable independently. Cycle and duty factor of output pulse is specifiable arbitrarily.
- Count clock is selectable among 6 internal clocks.
- The timer is usable as an interval timer, by generating interrupt requests for each interval.
- The time is usable as a D/A converter, with an external circuit.



# MB90385 Series

## • 8/16-bit PPG timer 1 block diagram

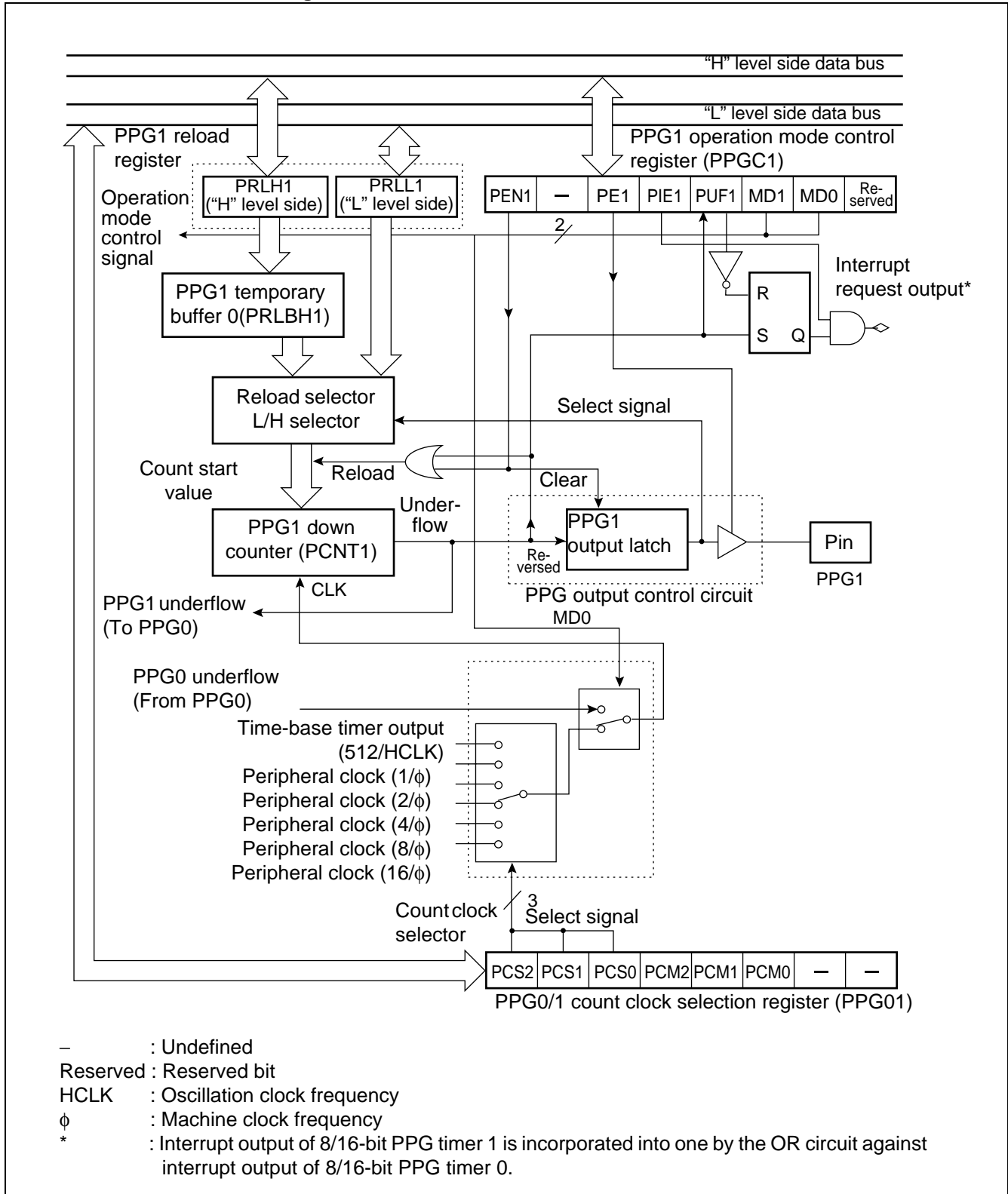

## 8. Delay Interrupt Generation Module Outline

The delay interrupt generation module is a module that generates interrupts for switching tasks. Generation of a hardware interrupt request is performed by software.

### • Delay interrupt generation module outline

Using the delay interrupt generation module, hardware interrupt request is generated and released by software.

### Delay interrupt generation module outline

	Function and control
Cause of interrupt	Set "1" in R0 bit of delay interrupt request generation/release register (DIRR: R0=1), generating an interrupt request. Set "0" in R0 bit of delay interrupt request generation/release register (DIRR: R0=0), releasing an interrupt request.
Interrupt number	#42 (2AH)
Interrupt control	No setting of permission register is provided.
Interrupt flag	Retained in DIRR: R0 bit
EI <sup>2</sup> OS	Not ready for expanded intelligent I/O service.

### • Delay interrupt generation module block diagram

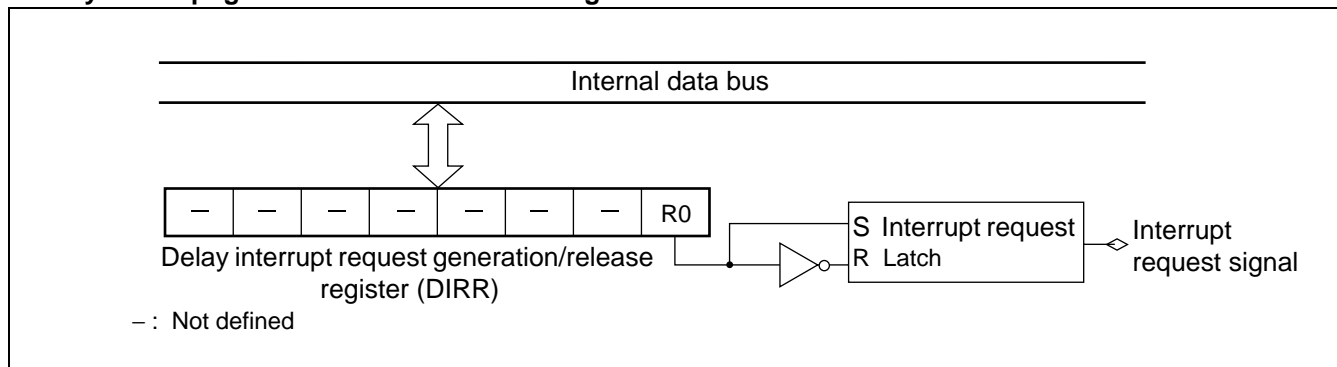

### • Interrupt request latch

A latch that retains settings on delay interrupt request generation/release register (generation or release of delay interrupt request).

### • Delay interrupt request generation/release register (DIRR)

Generates or releases delay interrupt request.

### • Interrupt number

An interrupt number used in delay interrupt generation module is as follows:

Interrupt number: #42 (2AH)

# MB90385 Series

## 9. DTP/External Interrupt and CAN Wakeup Outline

DTP/external interrupt transfers an interrupt request generated by an external peripheral device or a data transmission request to CPU, generating external interrupt request and activating expanded intelligent I/O service. Input RX of CAN controller is used as external interrupt input.

### • DTP/external interrupt and CAN wakeup function

An interrupt request input from external peripheral device to external input pins (INT7 to INT4) and RX pin, just as interrupt request of peripheral device, generates an interrupt request. The interrupt request generates an external interrupt and activates expanded intelligent I/O service (EI<sup>2</sup>OS).

If the expanded intelligent I/O service (EI<sup>2</sup>OS) has been disabled by interrupt control register (ICR: ISE=0), external interrupt function is enabled and branches to interrupt processing.

If the EI<sup>2</sup>OS has been enabled, (ICR: ISE=1), DTP function is enabled and automatic data transmission is performed by EI<sup>2</sup>OS. After performing specified number of data transmission processes, the process branches to interrupt processing.

### DTP/external interrupt and CAN wakeup outline

	External interrupt	DTP function
Input pin	5 pins (RX, and INT4 to INT7)	
Interrupt cause	Specify for each pin with detection level setting register (ELVR).	
	Input of "H" level/"L" level/rising edge/falling edge.	Input of "H" level/ "L" level
Interrupt number	#15 (0FH) , #24 (18H) , #27 (1BH)	
Interrupt control	Enabling or disabling output of interrupt request, using DTP/external interrupt permission register (ENIR).	
Interrupt flag	Retaining interrupt cause with DTP/external interrupt cause register (EIRR).	
Process selection	Disable EI <sup>2</sup> OS (ICR: ISE=0)	Enable EI <sup>2</sup> OS (ICR: ISE=1)
Process	Branch to external interrupt process	After automatic data transmission by EI <sup>2</sup> OS for specified number of times, branch to interrupt process.

• DTP/External interrupt/CAN wakeup block diagram

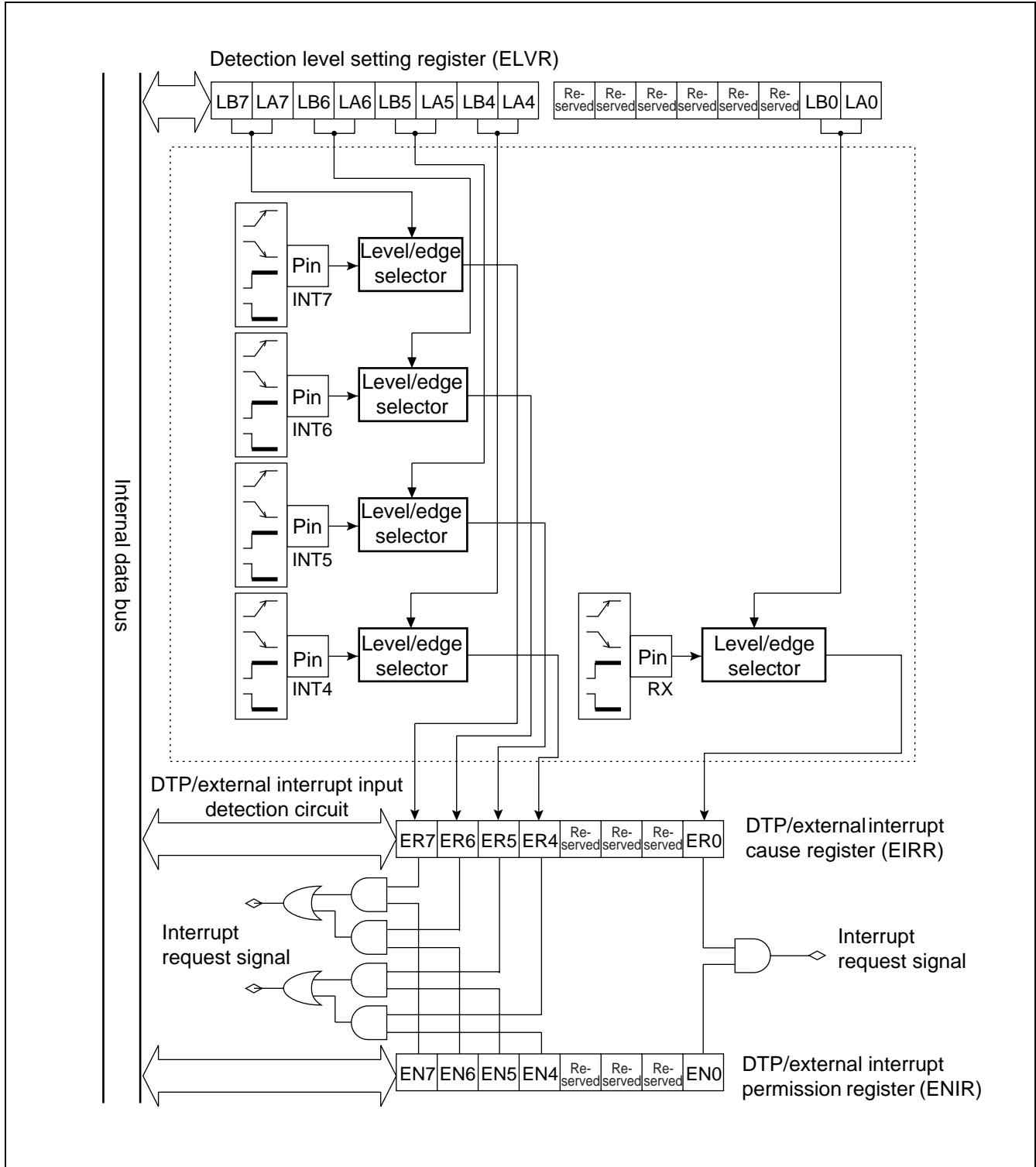

## 10. 8/10-bit A/D Converter

The 8/10-bit A/D converter converts an analog input voltage into 8-bit or 10-bit digital value, using the RC-type successive approximation conversion method.

- Input signal is selected among 8 channels of analog input pins.
- Activation trigger is selected among software trigger, internal timer output, and external trigger.

### • Functions of 8/10-bit A/D converter

The 8/10-bit A/D converter converts an analog voltage (input voltage) input to analog input pin into an 8-bit or 10-bit digital value (A/D conversion).

The 8/10-bit A/D converter has the following functions:

- A/D conversion takes a minimum of 6.12  $\mu\text{s}^*$  for 1 channel, including sampling time. (A/D conversion)
- Sampling of one channel takes a minimum of 2.0  $\mu\text{s}^*$ .
- RC-type successive approximation conversion method, with sample & hold circuit is used for conversion.
- Resolution of either 8 bits or 10 bits is specifiable.
- A maximum of 8 channels of analog input pins are allowed for use.
- Generation of interrupt request is allowed, by storing A/D conversion result in A/D data register.
- Activation of EI<sup>2</sup>OS is allowed upon occurrence of an interrupt request. With use of EI<sup>2</sup>OS, data loss is avoided even if A/D conversion is performed successively.
- An activation trigger is selectable among software trigger, internal timer output, and external trigger (fall edge).

\*: When operating with 16-MHz machine clock

### • 8/10-bit A/D converter conversion mode

Conversion mode	Description
Singular conversion mode	The A/D conversion is performed from a start channel to an end channel sequentially. Upon completion of A/D conversion on an end channel, A/D conversion function stops.
Sequential conversion mode	The A/D conversion is performed from a start channel to an end channel sequentially. Upon completion of A/D conversion on an end channel, A/D conversion function resumes from the start channel.
Pausing conversion mode	The A/D conversion is performed by pausing at each channel. Upon completion of A/D conversion on an end channel, A/D conversion and pause functions resume from the start channel.

• 8/10-bit A/D converter block diagram

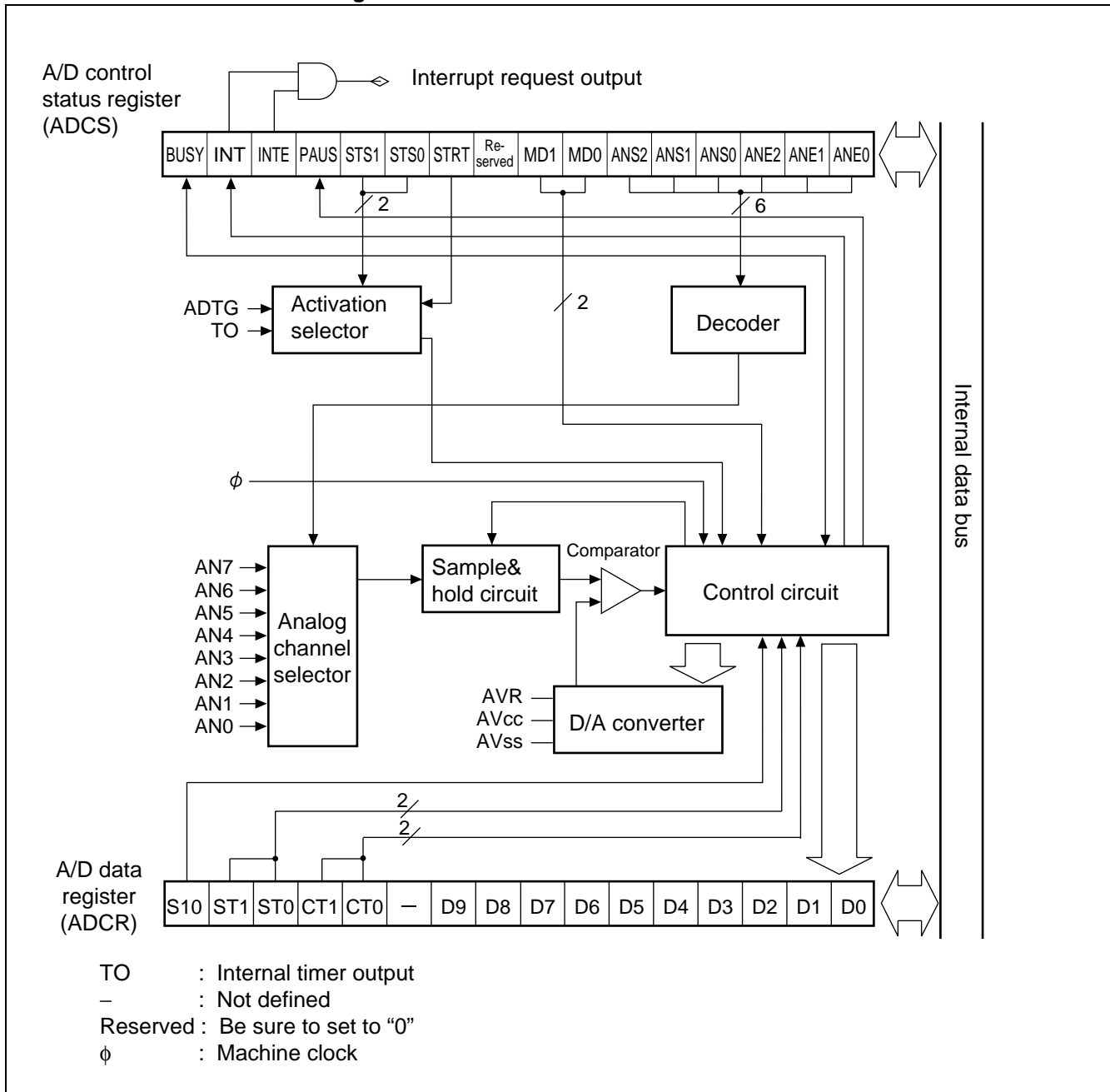

# MB90385 Series

## 11. UART Outline

UART is a general-purpose serial data communication interface for synchronous and asynchronous communication using external devices.

- Provided with bi-directional communication function for both clock-synchronous and clock-asynchronous modes.
- Provided with master/slave communication function (multi-processor mode). (Only master side is available.)
- Interrupt request is generated upon completion of reception, completion of transmission and detection of reception error.
- Ready for expanded intelligent service, EI<sup>2</sup>OS.

### UART functions

	Description
Data buffer	Full-duplex double buffer
Transmission mode	Clock synchronous (No start/stop bit, no parity bit) Clock asynchronous (start-stop synchronous)
Baud rate	Built-in special-purpose baud-rate generator. Setting is selectable among 8 values. Input of external values is allowed. Use of clock from external timer (16-bit reload timer 0) is allowed.
Data length	7 bits (only asynchronous normal mode) 8 bits
Signaling system	Non Return to Zero (NRZ) system
Reception error detection	Framing error Overrun error Parity error (not detectable in operation mode 1 (multi-processor mode))
Interrupt request	Receive interrupt (reception completed, reception error detected) Transmission interrupt (transmission completed) Ready for expanded intelligent I/O service (EI <sup>2</sup> OS) in both transmission and reception
Master/slave communication function (asynchronous, multi-processor mode)	Communication between 1 (master) and n (slaves) are available (usable as master only).

Note : Start/stop bit is not added upon clock-synchronous transmission. Data only is transmitted.

### UART operation modes

Operation mode	Data length		Synchronization	Stop bit length
	With parity	Without parity		
0 Asynchronous mode (normal mode)	7-bit or 8-bit		Asynchronous	1-bit or 2-bit *2
1 Multi processor mode	8+1 *1	—	Asynchronous	
2 Synchronous mode	8	—	Synchronous	No

— : Disallowed

\*1 : "+1" is an address/data selection bit used for communication control (bit 11 of SCR1 register: A/D).

\*2 : Only 1 bit is detected as a stop bit on data reception.

## • UART block diagram

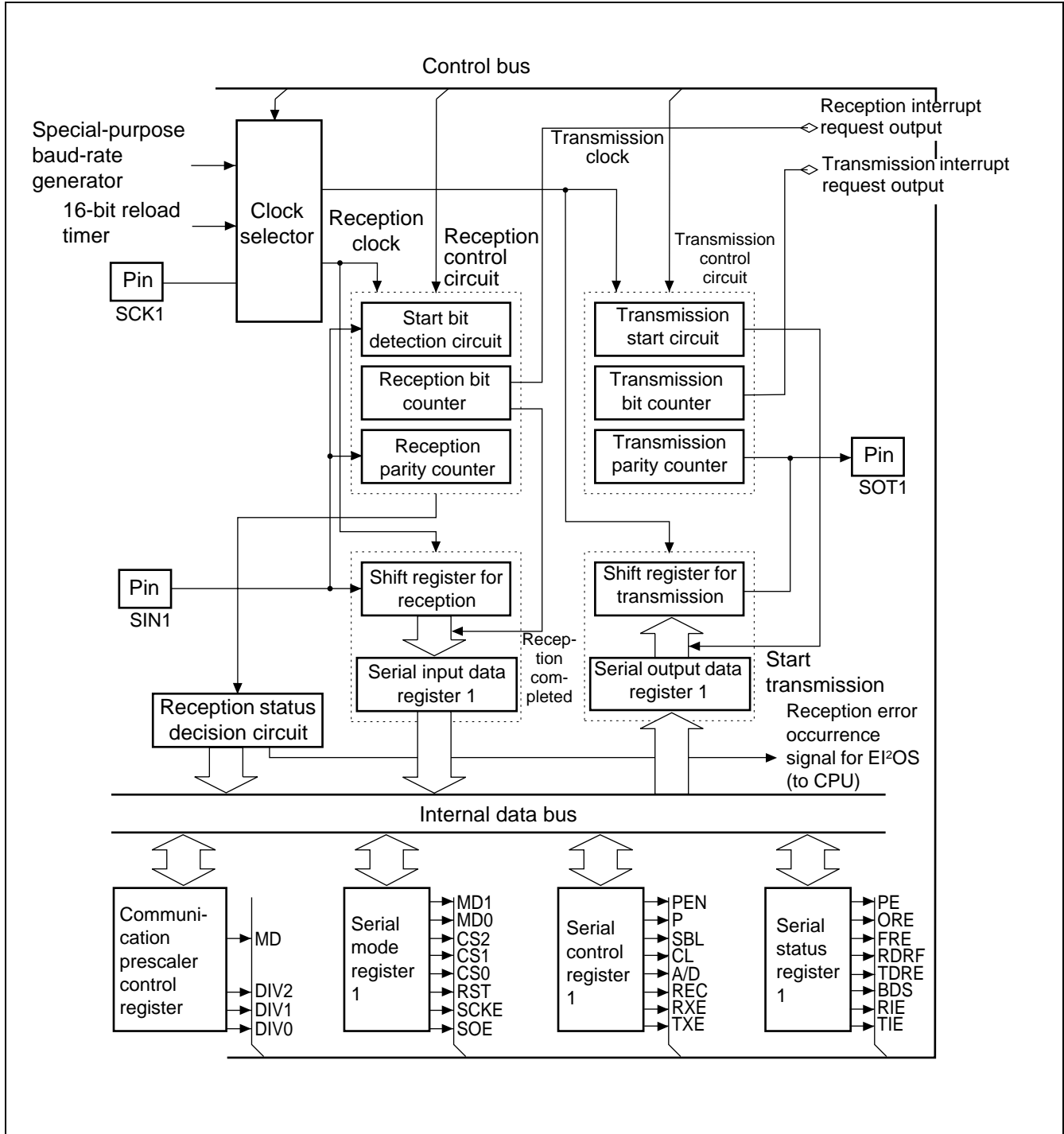

# MB90385 Series

## 12. CAN Controller

The Controller Area Network (CAN) is a serial communication protocol compliant with CANVer2.0A and Ver2.0B. The protocol allows data transmission and reception in both standard frame format and expanded frame format.

### • Features of CAN controller

- CAN controller format is compliant with CANVer2.0A and Ver2.0B.
- The protocol allows data transmission and reception in standard frame format and expanded frame format.
- Automatic transmission of data frame by remote frame reception is allowed.
- Baud rate ranges from 10 Kbps to 1 Mbps (with 16-MHz machine clock).

### Data transmission baud rate

Machine clock	Baud rate (Max)
16 MHz	1 Mbps
12 MHz	1 Mbps
8 MHz	1 Mbps
4 MHz	500 Kbps
2 MHz	250 Kbps

- Provided with 8 transmission/reception message buffers.
- Transmission/reception is allowed at ID11bit in standard format, and at ID29bit in expanded frame format.
- Specifying 0 byte to 8 bytes is allowed in message data.
- Multi-level message buffer configuration is allowed.
- CAN controller has two built-in acceptance masks. Mask settings are independently allowed for the two acceptance masks on reception IDs.
- The two acceptance masks allow reception in standard frame format and expanded frame format.
- For types of masking, all-bit comparison, all-bit masking, and partial masking with acceptance mask register 0/1, are specifiable.

## • CAN controller block diagram

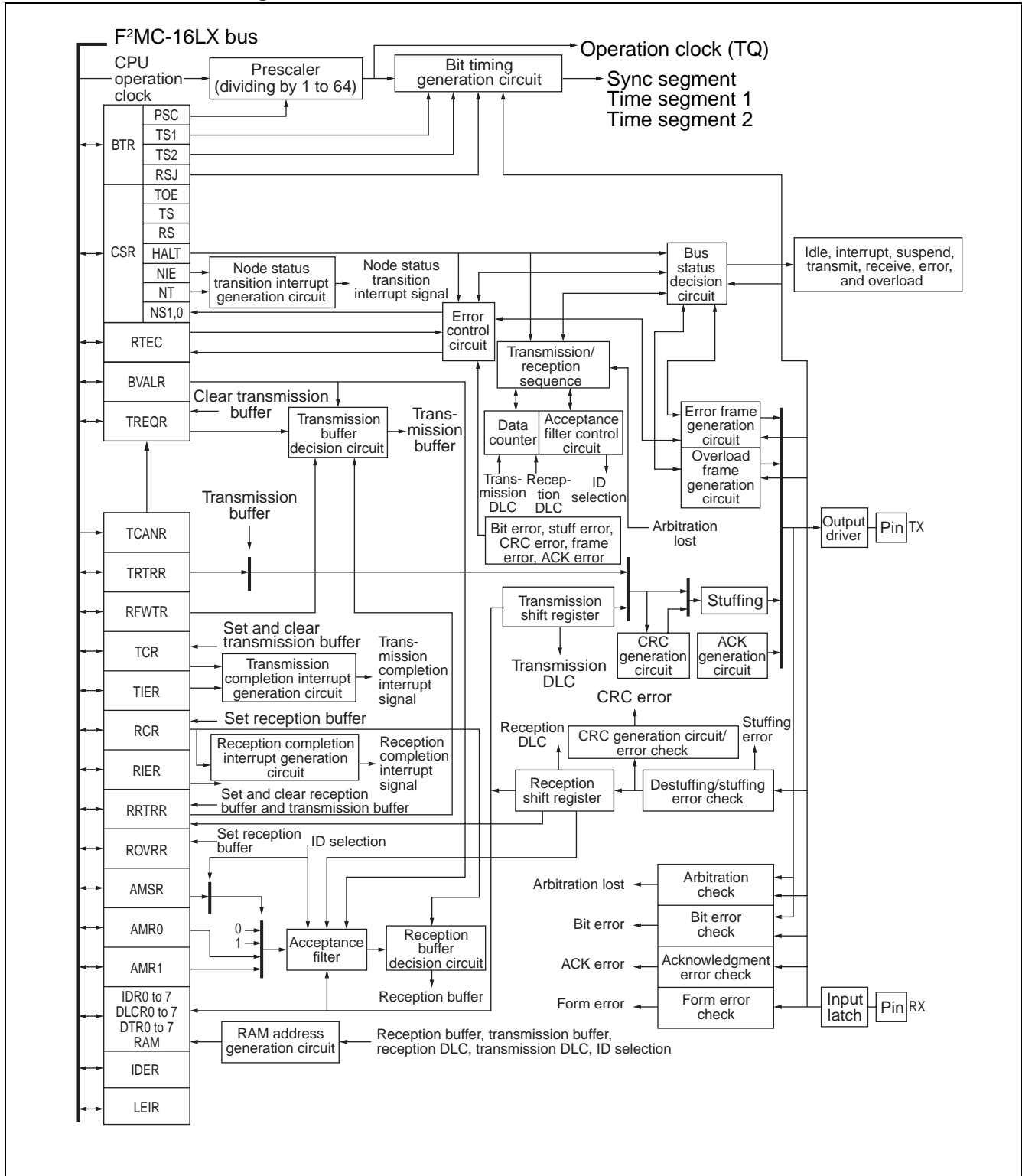

## 13. Address Matching Detection Function Outline

The address matching detection function checks if an address of an instruction to be processed next to a currently-processed instruction is identical with an address specified in the detection address register. If the addresses match with each other, an instruction to be processed next in program is forcibly replaced with INT9 instruction, and process branches to the interrupt process program. Using INT9 interrupt, this function is available for correcting program by batch processing.

### • Address matching detection function outline

- An address of an instruction to be processed next to a currently-processed instruction of the program is always retained in an address latch via internal data bus. By the address matching detection function, the address value retained in the address latch is always compared with an address specified in detection address setting register. If the compared address values match with each other, an instruction to be processed next by CPU is forcibly replaced with INT9 instruction, and an interrupt process program is executed.
- Two detection address setting registers are provided (PADR0 and PADR1), and each register is provided with interrupt permission bit. Generation of interrupt, which is caused by address matching between the address retained in address latch and the address specified in address setting register, is permitted and prohibited on a register-by-register basis.

### • Address matching detection function block diagram

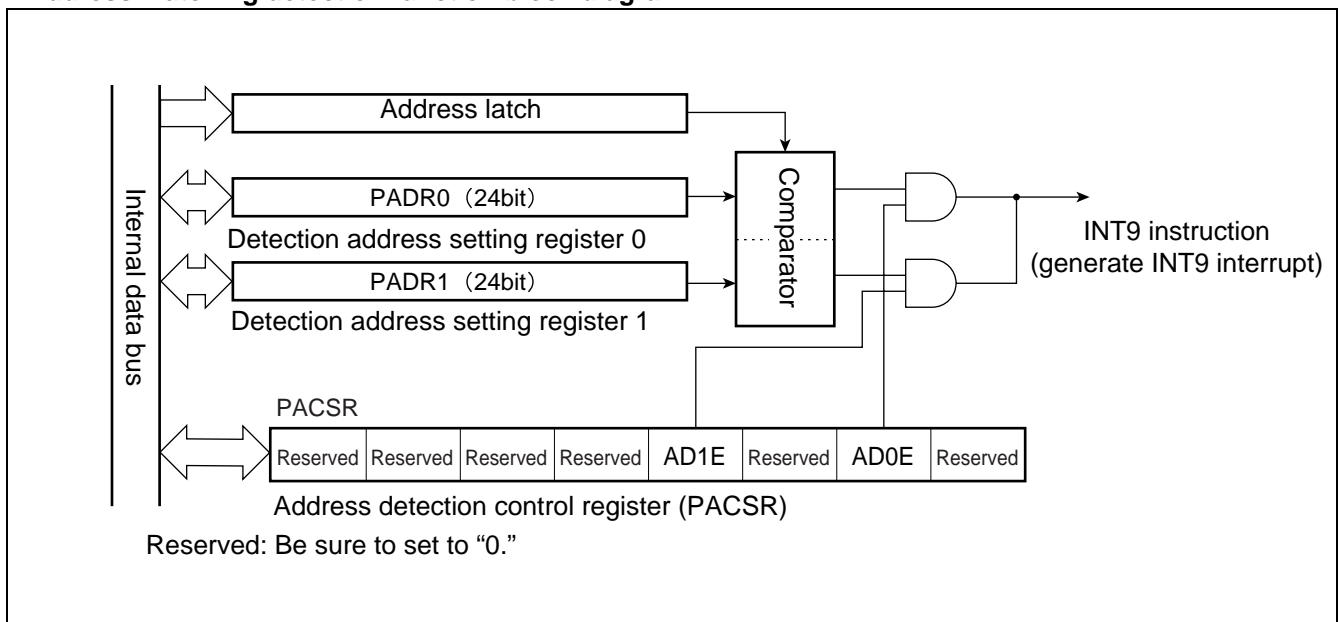

- Address latch  
Retains address value output to internal data bus.
- Address detection control register (PACSR)  
Specifies if interrupt is permitted or prohibited when addresses match with each other.
- Detection address setting (PADR0, PADR1)  
Specifies addresses to be compared with values in address latch.

## 14. ROM Mirror Function Selection Module Outline

The ROM mirror function selection module sets the data in ROM assigned to FF bank so that the data is read by access to 00 bank.

### • ROM mirror function selection module block diagram

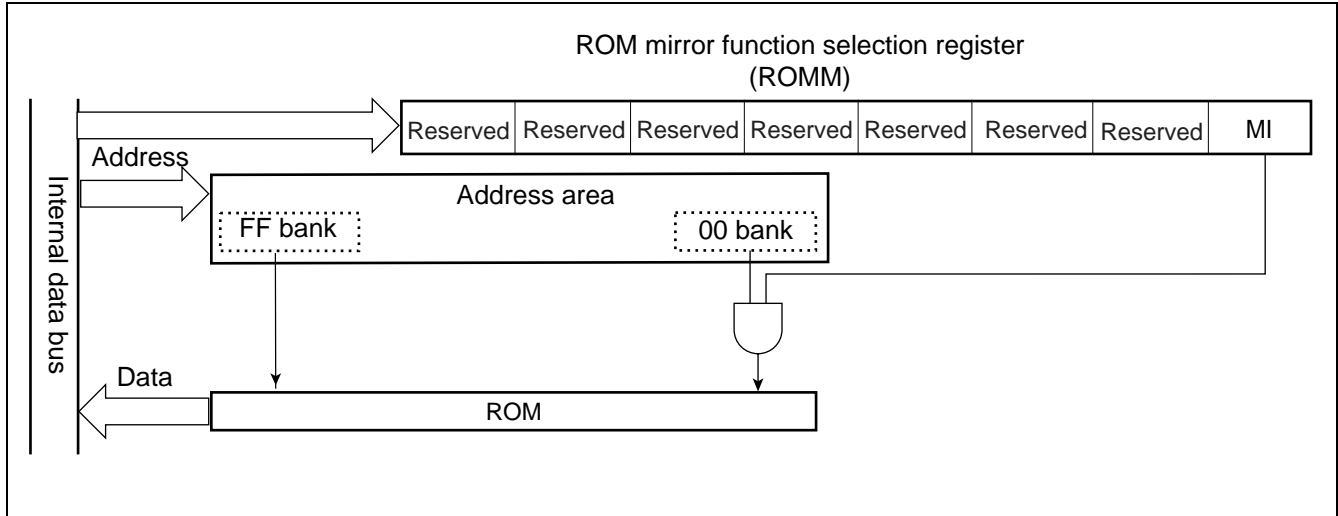

### • FF bank access by ROM mirror function

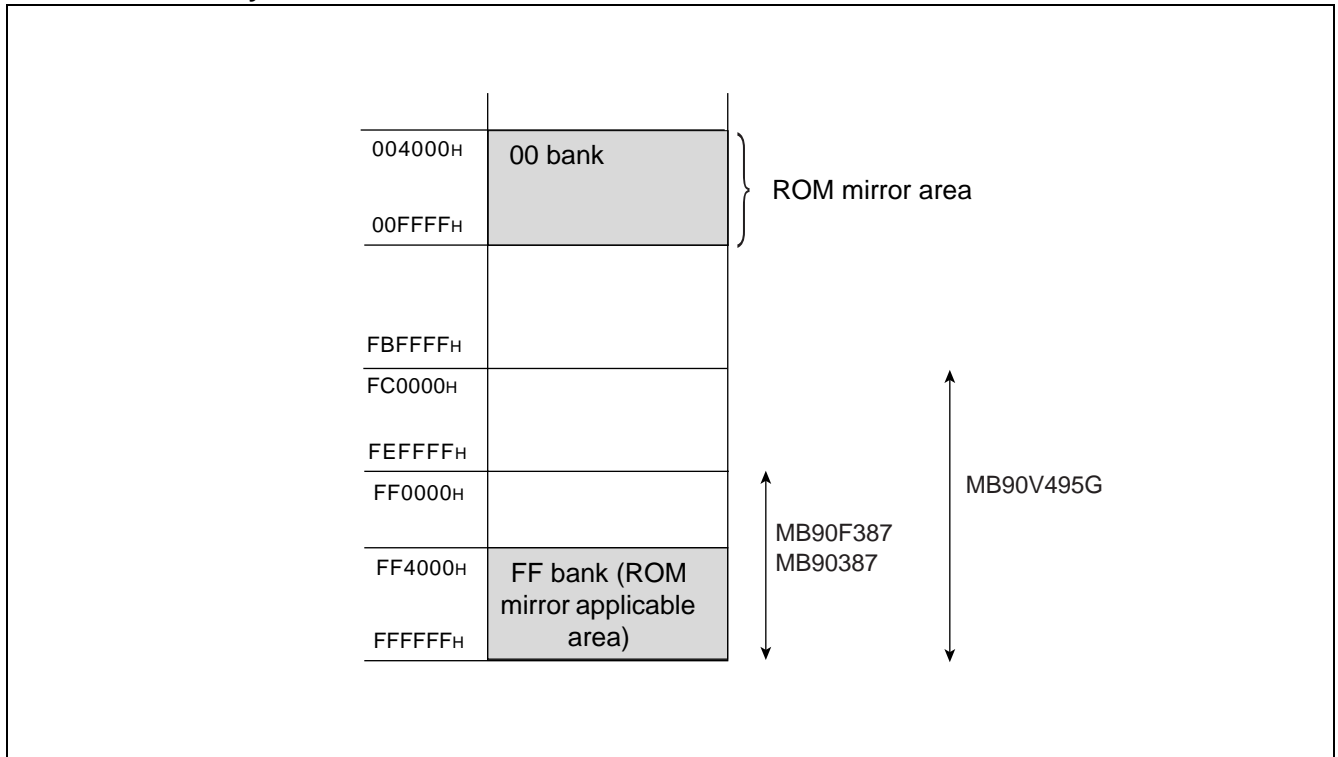

# MB90385 Series

## 15. 512 Kbit Flash Memory Outline

The following three methods are provided for data writing and deleting on flash memory:

1. Parallel writer
2. Serial special-purpose writer
3. Writing/deleting by program execution

This section describes “3. Writing/deleting by program execution.”

### • 512 Kbit flash memory outline

The 512K-bit flash memory is allocated on FF<sub>H</sub> bank of CPU memory map. Using the function of flash memory interface circuit, the memory allows read access and program access from CPU.

Writing/deleting on flash memory is performed by instruction from CPU via flash memory interface. Because rewriting is allowed on mounted memory, modifying program and data is performed efficiently.

### • Features of 512 Kbit flash memory

- 128 K words x 8 bits/64 K words x 16 bits (16 K + 8 K + 8 K + 32 K) sector configuration
- Automatic program algorithm (Embedded Algorithm™\* : Similar to MBM29LV200.)
- Built-in deletion pause/deletion resume function
- Detection of completed writing/deleting by data polling and toggle bits.
- Detection of completed writing/deleting by CPU interrupt.
- Deletion is allowed on a sector-by-sector basis (sectors are combined freely).
- Number of writing/deleting operations (minimum): 10,000 times
- Sector protection
- Expanded sector protection
- Temporal sector unprotection

\* : Embedded Algorithm™ is a registered trademark of Advanced Micro Devices.

Note : A function of reading manufacture code and device code is not provided. These codes are not accessible by command either.

### • Flash memory writing/deleting

- Writing and reading data is not allowed simultaneously on the flash memory.
- Data writing and deleting on the flash memory is performed by the processes as follows: Make a copy of program on flash memory onto RAM. Then, execute the program copied on the RAM.

### • List of registers and reset values in flash memory

Flash memory control status register (FMCS)

bit

7	6	5	4	3	2	1	0
0	0	0	X	0	0	0	0

× : Undefined

- **Sector configuration**

For access from CPU, SA0 to SA3 are allocated in FF bank register.

- **Sector configuration of 512 Kbit flash memory**

Flash memory	CPU address	Writer address*
SA0 (32 Kbytes)	FF0000H	70000H
	FF7FFFH	77FFFH
SA1 (8 Kbytes)	FF8000H	78000H
	FF9FFFH	79FFFH
SA2 (8 Kbytes)	FFA000H	7A000H
	FFBFFFH	7BFFFH
SA3 (16 Kbytes)	FFC000H	7C000H
	FFFFFFH	7FFFFH

\*: "Writer address" is an address equivalent to CPU address, which is used when data is written on flash memory, using parallel writer. When writing/deleting data with general-purpose writer, the writer address is used for writing and deleting.

# MB90385 Series

## ■ ELECTRIC CHARACTERISTICS

### 1. Absolute Maximum Rating

( $V_{SS} = AV_{SS} = 0\text{ V}$ )

Parameter	Symbol	Rating		Unit	Remarks
		Min	Max		
Power supply voltage	$V_{CC}$	$V_{SS} - 0.3$	$V_{SS} + 6.0$	V	
	$AV_{CC}$	$V_{SS} - 0.3$	$V_{SS} + 6.0$	V	$V_{CC} = AV_{CC}^{*1}$
	AVR	$V_{SS} - 0.3$	$V_{SS} + 6.0$	V	$AV_{CC} \geq AVR^{*1}$
Input voltage	$V_I$	$V_{SS} - 0.3$	$V_{SS} + 6.0$	V	*2
Output voltage	$V_O$	$V_{SS} - 0.3$	$V_{SS} + 6.0$	V	*2
Maximum clamp current	$I_{CLAMP}$	-2.0	+2.0	mA	*6
Total maximum clamp current	$\sum  I_{CLAMP} $	—	20	mA	*6
“L” level maximum output current	$I_{OL1}$	—	15	mA	Normal output*3
	$I_{OL2}$	—	40	mA	High-current output*3
“L” level average output current	$I_{OLAV1}$	—	4	mA	Normal output*4
	$I_{OLAV2}$	—	30	mA	High-current output*4
“L” level maximum total output current	$\sum I_{OL1}$	—	125	mA	Normal output
	$\sum I_{OL2}$	—	160	mA	High-current output
“L” level average total output current	$\sum I_{OLAV1}$	—	40	mA	Normal output*5
	$\sum I_{OLAV2}$	—	40	mA	High-current output*5
“H” level maximum output current	$I_{OH1}$	—	-15	mA	Normal output*3
	$I_{OH2}$	—	-40	mA	High-current output*3
“H” level average output current	$I_{OHAV1}$	—	-4	mA	Normal output*4
	$I_{OHAV2}$	—	-30	mA	High-current output*4
“H” level maximum total output current	$\sum I_{OH1}$	—	-125	mA	Normal output
	$\sum I_{OH2}$	—	-160	mA	High-current output
“H” level average total output current	$\sum I_{OHAV1}$	—	-40	mA	Normal output*5
	$\sum I_{OHAV2}$	—	-40	mA	High-current output*5
Power consumption	$P_D$	—	245	mW	
Operating temperature	$T_A$	-40	+105	°C	
Storage temperature	$T_{stg}$	-55	+150	°C	

\*1 :  $AV_{CC}$  and AVR should not exceed  $V_{CC}$ .

\*2 :  $V_I$  and  $V_O$  should not exceed  $V_{CC} + 0.3\text{ V}$ .

\*3 : A peak value of an applicable one pin is specified as a maximum output current.

\*4 : An average current value of an applicable one pin within 100 ms is specified as an average output current. (Average value is found by multiplying operating current by operating rate.)

\*5 : An average current value of all pins within 100 ms is specified as an average total output current. (Average value is found by multiplying operating current by operating rate.)

(Continued)

(Continued)

- \*6 : • Applicable to pins: P10 to P17, P20 to P27, P30 to P33, P35\*, P36\*, P37, P40 to P44, P50 to P57
  - \*: P35 and P36 are MB90387S and MB90F387S only.
- Use within recommended operating conditions.
- Use at DC voltage (current) .
- The +B signal should always be applied a limiting resistance placed between the +B signal and the microcontroller.
- The value of the limiting resistance should be set so that when the +B signal is applied the input current to the microcontroller pin does not exceed rated values, either instantaneously or for prolonged periods.
- Note that when the microcontroller drive current is low, such as in the power saving modes, the +B input potential may pass through the protective diode and increase the potential at the V<sub>CC</sub> pin, and this may affect other devices.
- Note that if a +B signal is input when the microcontroller power supply is off (not fixed at 0 V) , the power supply is provided from the pins, so that incomplete operation may result.
- Note that if the +B input is applied during power-on, the power supply is provided from the pins and the resulting supply voltage may not be sufficient to operate the power-on reset.
- Care must be taken not to leave the +B input pin open.
- Note that analog system input/output pins other than the A/D input pins (LCD drive pins, comparator input pins, etc.) cannot accept +B signal input.
- Sample recommended circuits:

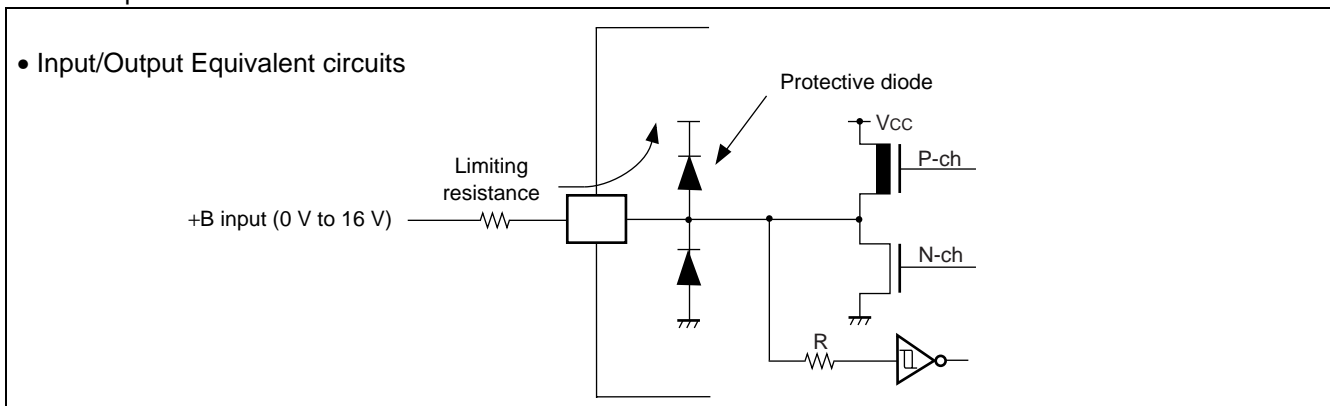

**WARNING:** Semiconductor devices can be permanently damaged by application of stress (voltage, current, temperature, etc.) in excess of absolute maximum ratings. Do not exceed these ratings.

# MB90385 Series

## 2. Recommended Operating Conditions

( $V_{SS} = AV_{SS} = 0.0V$ )

Parameter	Symbol	Value			Unit	Remarks
		Min	Typ	Max		
Power supply voltage	$V_{CC}$	3.5	5.0	5.5	V	Under normal operation
		3.0	—	5.5	V	Retain status of stop operation
	$AV_{CC}$	4.0	—	5.5	V	*2
Smoothing capacitor	$C_S$	0.1	—	1.0	$\mu F$	*1
Operating temperature	$T_A$	-40	—	+105	$^{\circ}C$	

\*1 : Use a ceramic capacitor, or a capacitor of similar frequency characteristics. On the  $V_{CC}$  pin, use a bypass capacitor that has a larger capacity than that of  $C_S$ .  
Refer to the following figure for connection of smoothing capacitor  $C_S$ .

\*2 :  $AV_{CC}$  is a voltage at which accuracy is guaranteed.  $AV_{CC}$  should not exceed  $V_{CC}$ .

- C pin connection diagram

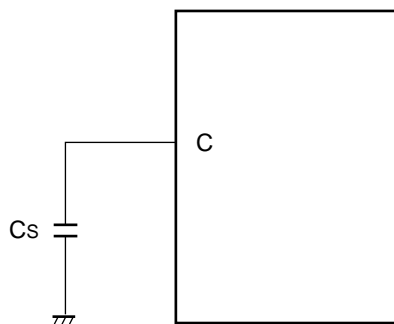

**WARNING:** The recommended operating conditions are required in order to ensure the normal operation of the semiconductor device. All of the device's electrical characteristics are warranted when the device is operated within these ranges.

Always use semiconductor devices within their recommended operating condition ranges. Operation outside these ranges may adversely affect reliability and could result in device failure.

No warranty is made with respect to uses, operating conditions, or combinations not represented on the data sheet. Users considering application outside the listed conditions are advised to contact their FUJITSU representatives beforehand.

# MB90385 Series

## 3. DC Characteristics

( $V_{CC} = 5.0\text{ V} \pm 10\%$ ,  $V_{SS} = AV_{SS} = 0.0\text{ V}$ ,  $T_A = -40\text{ }^\circ\text{C}$  to  $+105\text{ }^\circ\text{C}$ )

Parameter	Symbol	Pin name	Conditions	Value			Unit	Remarks
				Min	Typ	Max		
“H” level input voltage	$V_{IHS}$	CMOS hysteresis input pin	—	$0.8 V_{CC}$	—	$V_{CC} + 0.3$	V	
	$V_{IHM}$	MD input pin	—	$V_{CC} - 0.3$	—	$V_{CC} + 0.3$	V	
“L” level input voltage	$V_{ILS}$	CMOS hysteresis input pin	—	$V_{SS} - 0.3$	—	$0.2 V_{CC}$	V	
	$V_{ILM}$	MD input pin	—	$V_{SS} - 0.3$	—	$V_{SS} + 0.3$	V	
“H” level output voltage	$V_{OH1}$	Pins other than P14 to P17	$V_{CC} = 4.5\text{ V}$ , $I_{OH} = -4.0\text{ mA}$	$V_{CC} - 0.5$	—	—	V	
	$V_{OH2}$	P14 to P17	$V_{CC} = 4.5\text{ V}$ , $I_{OH} = -14.0\text{ mA}$	$V_{CC} - 0.5$	—	—	V	
“L” level output voltage	$V_{OL1}$	Pins other than P14 to P17	$V_{CC} = 4.5\text{ V}$ , $I_{OL} = 4.0\text{ mA}$	—	—	0.4	V	
	$V_{OL2}$	P14 to P17	$V_{CC} = 4.5\text{ V}$ , $I_{OL} = 20.0\text{ mA}$	—	—	0.4	V	
Input leak current	$I_{IL}$	All input pins	$V_{CC} = 5.5\text{ V}$ , $V_{SS} < V_I < V_{CC}$	-5	—	+5	$\mu\text{A}$	
Power supply current*	$I_{CC}$	$V_{CC}$	$V_{CC} = 5.0\text{ V}$ , Internally operating at 16 MHz, normal operation.	—	25	30	mA	
			$V_{CC} = 5.0\text{ V}$ , Internally operating at 16 MHz, writing on flash memory.	—	45	50	mA	MB90F387/S
			$V_{CC} = 5.0\text{ V}$ , Internally operating at 16 MHz, deleting on flash memory.	—	45	50	mA	MB90F387/S
	$I_{CCS}$		$V_{CC} = 5.0\text{ V}$ , Internally operating at 16 MHz, sleeping.	—	8	12	mA	
	$I_{CTS}$		$V_{CC} = 5.0\text{ V}$ , Internally operating at 2 MHz, transition from main clock mode, in time-base timer mode.	—	0.75	1.0	mA	MB90F387/S
0.2		0.35	MB90387/S					

(Continued)

# MB90385 Series

(Continued)

( $V_{CC} = 5.0 V \pm 10\%$ ,  $V_{SS} = AV_{SS} = 0.0 V$ ,  $T_A = -40\text{ }^\circ\text{C}$  to  $+105\text{ }^\circ\text{C}$ )

Parameter	Symbol	Pin name	Conditions	Rating			Unit	Remarks
				Min	Typ	Max		
Power supply current*	I <sub>CC</sub> L	V <sub>CC</sub>	V <sub>CC</sub> = 5.0 V, Internally operating at 8 kHz, subclock operation, T <sub>A</sub> = +25°C	—	0.3	1.2	mA	MB90F387/S
			—	40	100	μA	MB90387/S	
	I <sub>CC</sub> LS		V <sub>CC</sub> = 5.0 V, Internally operating at 8 kHz, subclock, sleep mode, T <sub>A</sub> = +25°C	—	10	30	μA	
	I <sub>CC</sub> T		V <sub>CC</sub> = 5.0 V, Internally operating at 8 kHz, clock mode, T <sub>A</sub> = +25°C	—	8	25	μA	
	I <sub>CC</sub> H		Stopping, T <sub>A</sub> = +25°C	—	5	20	μA	
Input capacity	C <sub>IN</sub>	Other than AV <sub>CC</sub> , AV <sub>SS</sub> , AVR, C, V <sub>CC</sub> , V <sub>SS</sub>	—	—	5	15	pF	
Pull-up resistor	R <sub>UP</sub>	$\overline{RST}$	—	25	50	100	kΩ	
Pull-down resistor	R <sub>DOWN</sub>	MD2	—	25	50	100	kΩ	FLASH product is not provided with pull-down resistor.

\* : Test conditions of power supply current are based on a device using external clock.

## 4. AC Characteristics

### (1) Clock timing

( $V_{CC} = 5.0 V \pm 10\%$ ,  $V_{SS} = AV_{SS} = 0.0 V$ ,  $T_A = -40\text{ }^\circ\text{C}$  to  $+105\text{ }^\circ\text{C}$ )

Parameter	Symbol	Pin name	Value			Unit	Remarks
			Min	Typ	Max		
Clock frequency	$f_C$	X0, X1	3	—	8	MHz	When crystal or ceramic resonator is used*2
			3	—	16	MHz	External clock *1, *2
Clock cycle time	$t_{HCYL}$	X0, X1	125	—	333	ns	
	$t_{LCYL}$	X0A, X1A	—	30.5	—	$\mu\text{s}$	
Input clock pulse width	$P_{WH}, P_{WL}$	X0	10	—	—	ns	Set duty factor at 30% to 70% as a guideline.
	$P_{WLH}, P_{WLL}$	X0A	—	15.2	—	$\mu\text{s}$	
Input clock rise time and fall time	$t_{CR}, t_{CF}$	X0	—	—	5	ns	When external clock is used
Internal operation clock frequency	$f_{CP}$	—	1.5	—	16	MHz	When main clock is used
	$f_{LCP}$	—	—	8.192	—	kHz	When sub clock is used
Internal operation clock cycle time	$t_{CP}$	—	62.5	—	666	ns	When main clock is used
	$t_{LCP}$	—	—	122.1	—	$\mu\text{s}$	When sub clock is used

\*1 : Internal operation clock frequency should not exceed 16 MHz.

\*2 : When selecting the PLL clock, the range of clock frequency is limited. Use this product within range as mentioned in "Relation among external clock frequency and internal clock frequency".

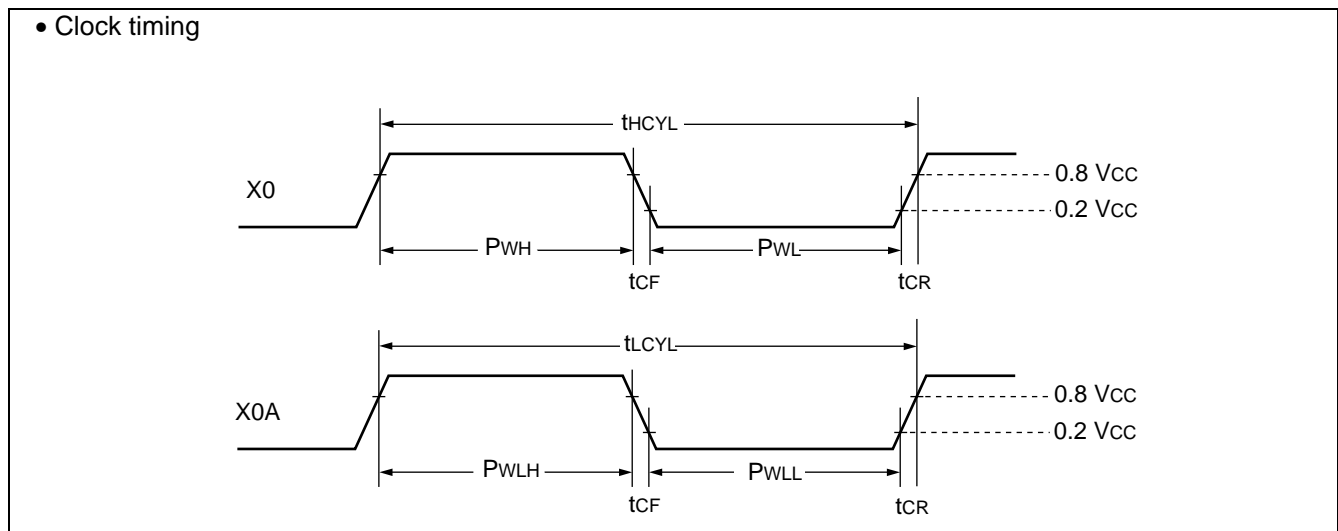

# MB90385 Series

- PLL operation guarantee range

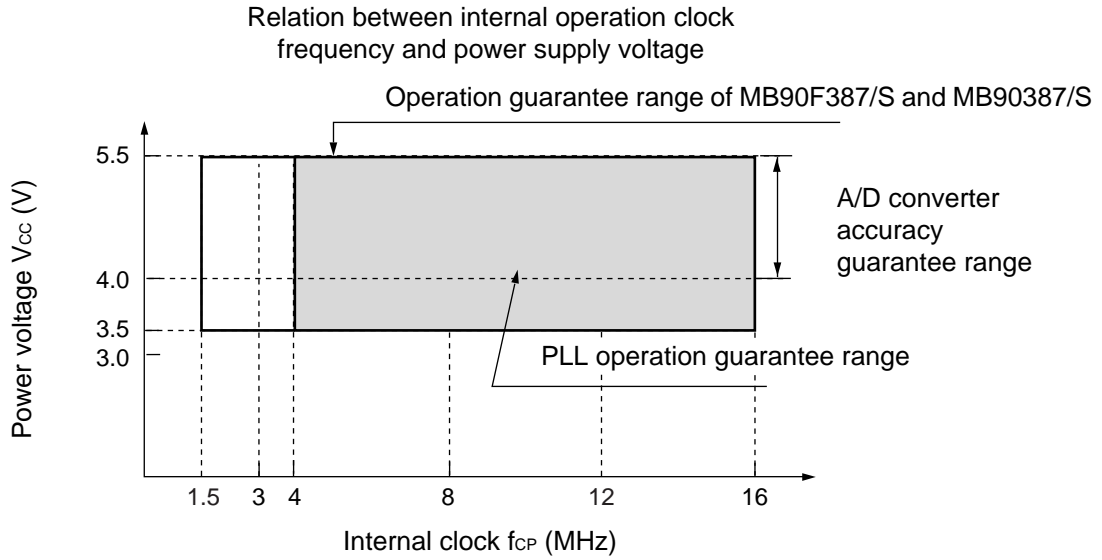

Relation among external clock frequency and internal clock frequency

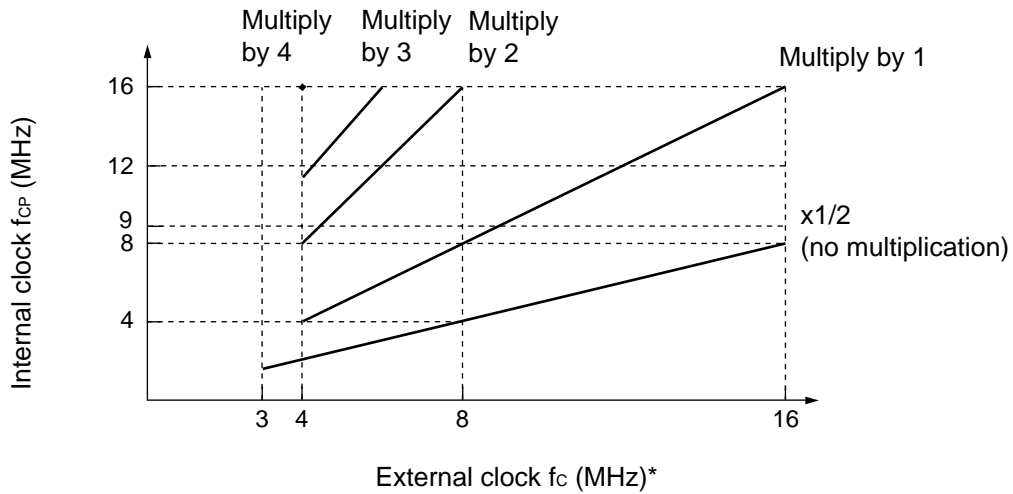

\* :  $f_c$  is 8 MHz at maximum when crystal or ceramic resonator circuit is used.

Rating values of alternating current is defined by the measurement reference voltage values shown below:

- Input signal waveform

Hysteresis input pin

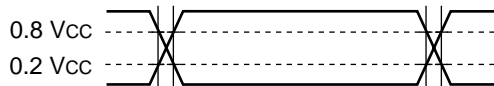

- Output signal waveform

Output pin

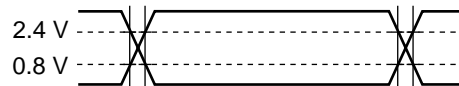

## (2) Reset input timing

Parameter	Symbol	Pin name	Value		Unit	Remarks
			Min	Max		
Reset input time	$t_{RSTL}$	$\overline{RST}$	$16 t_{CP}^{*3}$	—	ns	Normal operation
			Oscillation time of oscillator* <sup>1</sup> + $100 \mu s + 16 t_{CP}^{*3}$	—	—	In sub clock* <sup>2</sup> , sub sleep* <sup>2</sup> , watch* <sup>2</sup> and stop mode
			100	—	$\mu s$	In timebase timer

\*1 : Oscillation time of oscillator is time that the amplitude reached the 90%. In the crystal oscillator, the oscillation time is between several ms to tens of ms. In FAR/ceramic oscillator, the oscillation time is between hundreds of  $\mu s$  to several ms. In the external clock, the oscillation time is 0 ms.

\*2 : Except for MB90F387S and MB90387S.

\*3 : Refer to "(1) Clock timing" ratings for  $t_{CP}$  (internal operation clock cycle time).

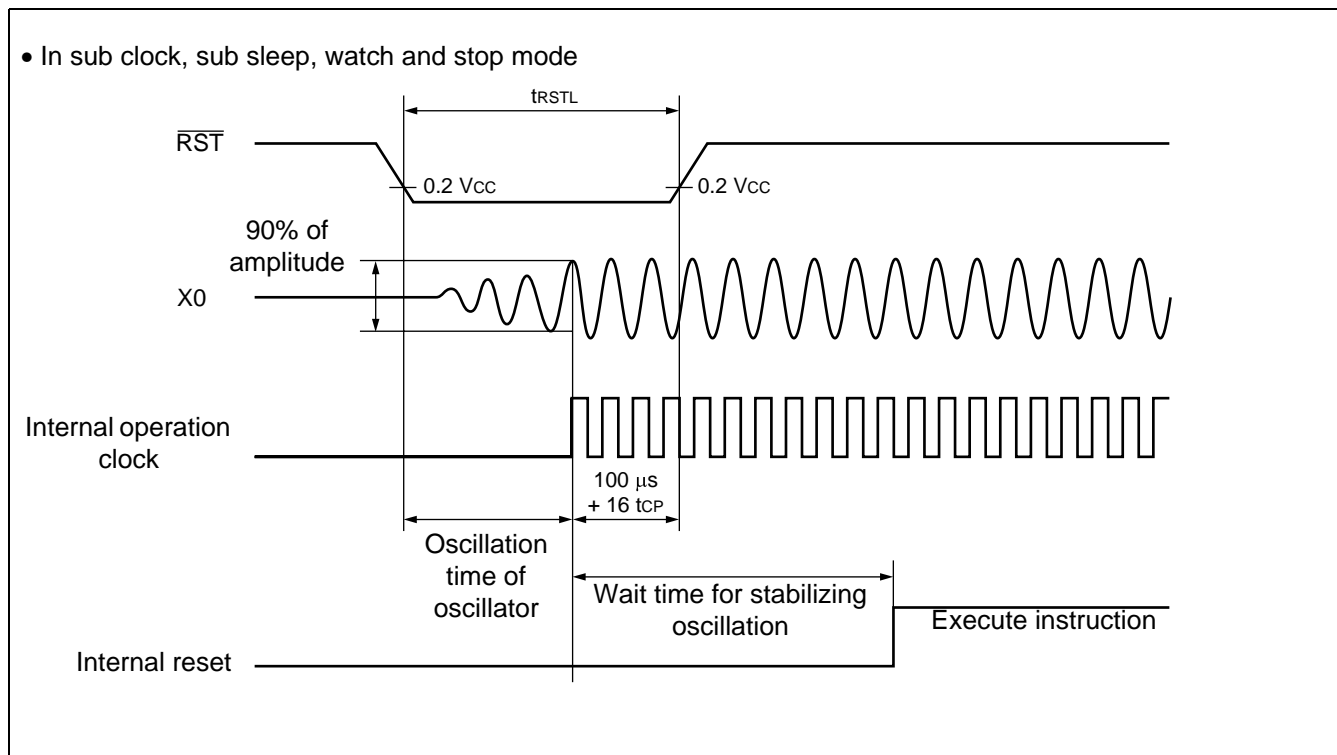

# MB90385 Series

## (3) Power-on reset

( $V_{CC} = 5.0\text{ V} \pm 10\%$ ,  $V_{SS} = AV_{SS} = 0.0\text{ V}$ ,  $T_A = -40\text{ }^\circ\text{C}$  to  $+105\text{ }^\circ\text{C}$ )

Parameter	Symbol	Pin name	Conditions	Value		Unit	Remarks
				Min	Max		
Power supply rise time	$t_R$	$V_{CC}$	—	0.05	30	ms	
Power supply shutdown time	$t_{OFF}$	$V_{CC}$		1	—	ms	Repeated operation



Sudden change of power supply voltage may activate the power-on reset function. When changing power supply voltages during operation, raise the power smoothly by suppressing variation of voltages as shown below. When raising the power, do not use PLL clock. However, if voltage drop is  $1\text{ V/s}$  or less, use of PLL clock is allowed during operation.

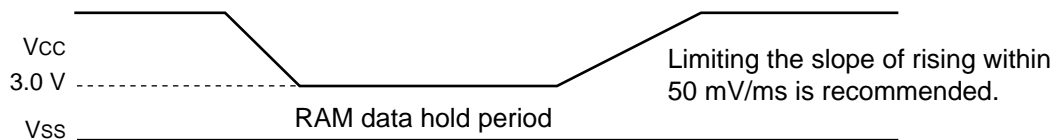

## (4) UART timing

(V<sub>CC</sub> = 4.5 V to 5.5 V, V<sub>SS</sub> = 0.0 V, T<sub>A</sub> = -40 °C to +105 °C)

Parameter	Symbol	Pin name	Conditions	Value		Unit	Remarks
				Min	Max		
Serial clock cycle time	t <sub>SCYC</sub>	SCK1	Internal shift clock mode output pin is : CL = 80 pF+1TTL.	8 t <sub>CP</sub> *	—	ns	
SCK ↓ → SOT delay time	t <sub>SLOV</sub>	SCK1, SOT1		-80	+80	ns	
Valid SIN → SCK ↑	t <sub>IVSH</sub>	SCK1, SIN1		100	—	ns	
SCK ↑ → valid SIN hold time	t <sub>SHIX</sub>	SCK1, SIN1		60	—	ns	
Serial clock "H" pulse width	t <sub>SHSL</sub>	SCK1	External shift clock mode output pin is : CL = 80 pF+1TTL.	4 t <sub>CP</sub> *	—	ns	
Serial clock "L" pulse width	t <sub>LSLH</sub>	SCK1		4 t <sub>CP</sub> *	—	ns	
SCK ↓ → SOT delay time	t <sub>SLOV</sub>	SCK1, SOT1		—	150	ns	
Valid SIN → SCK ↑	t <sub>IVSH</sub>	SCK1, SIN1		60	—	ns	
SCK ↑ → valid SIN hold time	t <sub>SHIX</sub>	SCK1, SIN1		60	—	ns	

\* : Refer to "(1) Clock timing" ratings for t<sub>CP</sub> (internal operation clock cycle time).

- Notes:
- AC rating in CLK synchronous mode.
  - C<sub>L</sub> is a load capacitance value on pins for testing.

# MB90385 Series

- Internal shift clock mode

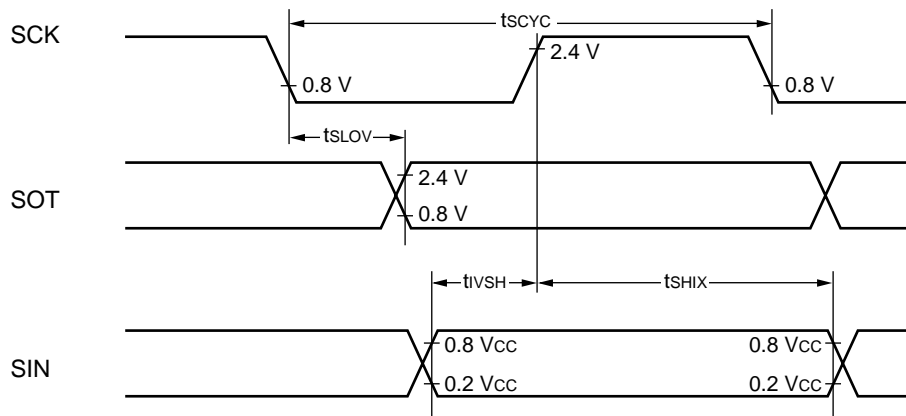

- External shift clock mode

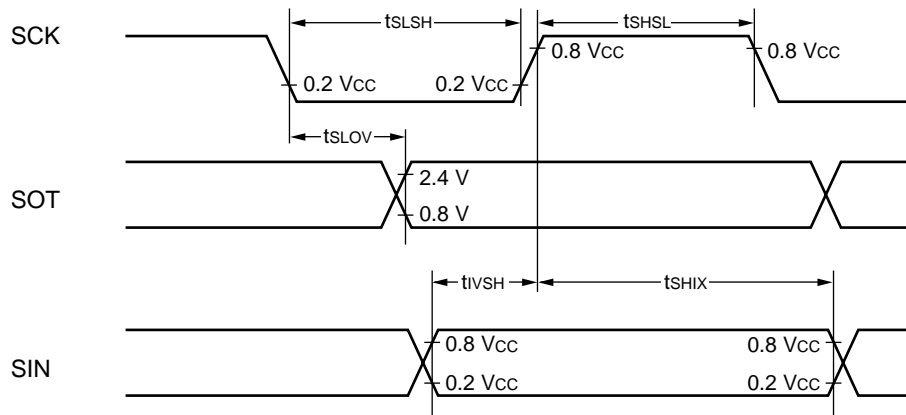

## (5) Timer input timing

( $V_{CC} = 4.5\text{ V to }5.5\text{ V}$ ,  $V_{SS} = 0.0\text{ V}$ ,  $T_A = -40\text{ }^\circ\text{C to }+105\text{ }^\circ\text{C}$ )

Parameter	Symbol	Pin name	Conditions	Value		Unit	Remarks
				Min	Max		
Input pulse width	$t_{TIWH}$	TIN0, TIN1	—	4 $t_{CP}$ *	—	ns	
	$t_{TIWL}$	IN0 to IN3					

\* : Refer to "(1) Clock timing" ratings for  $t_{CP}$  (internal operation clock cycle time).

### • Timer input timing

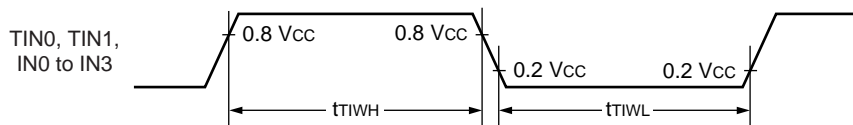

## (6) Trigger input timing

( $V_{CC} = 4.5\text{ V to }5.5\text{ V}$ ,  $V_{SS} = 0.0\text{ V}$ ,  $T_A = -40\text{ }^\circ\text{C to }+105\text{ }^\circ\text{C}$ )

Parameter	Symbol	Pin name	Conditions	Value		Unit	Remarks
				Min	Max		
Input pulse width	$t_{TRGH}$	INT4 to INT7, ADTG	—	5 $t_{CP}$ *	—	ns	
	$t_{TRGL}$						

\* : Refer to "(1) Clock timing" ratings for  $t_{CP}$  (internal operation clock cycle time).

### • Trigger input timing

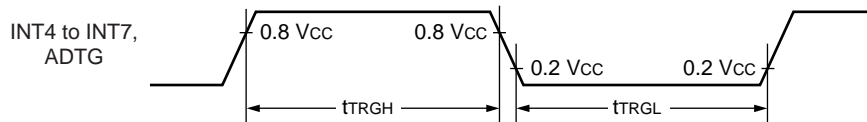

# MB90385 Series

## 5. A/D converter

( $V_{CC} = AV_{CC} = 5.0 \text{ V} \pm 10\%$ ,  $V_{SS} = AV_{SS} = 0.0 \text{ V}$ ,  $3.0 \text{ V} \leq AVR - AV_{SS}$ ,  $T_A = -40 \text{ }^\circ\text{C}$  to  $+105 \text{ }^\circ\text{C}$ )

Parameter	Symbol	Pin name	Conditions	Value		Unit	Remarks
				Min	Max		
Resolution	—	—	—	—	10	bit	
Total error	—	—	—	—	$\pm 3.0$	LSB	
Nonlinear error	—	—	—	—	$\pm 2.5$	LSB	
Differential linear error	—	—	—	—	$\pm 1.9$	LSB	
Zero transition voltage	$V_{OT}$	AN0 to AN7	$AV_{SS} - 1.5$ LSB	$AV_{SS} + 0.5$ LSB	$AV_{SS} + 2.5$ LSB	V	1 LSB = AVR/1024
Full-scale transition voltage	$V_{FST}$	AN0 to AN7	$AVR - 3.5$ LSB	$AVR - 1.5$ LSB	$AVR + 0.5$ LSB	V	
Compare time	—	—	$66 t_{CP}^{*1}$	—	—	ns	With 16 MHz machine clock $5.5 \text{ V} \geq AV_{CC} \geq 4.5 \text{ V}$
			$88 t_{CP}^{*1}$	—	—	ns	With 16 MHz machine clock $4.5 \text{ V} > AV_{CC} \geq 4.0 \text{ V}$
Sampling time	—	—	$32 t_{CP}^{*1}$	—	—	ns	With 16 MHz machine clock $5.5 \text{ V} \geq AV_{CC} \geq 4.5 \text{ V}$
			$128 t_{CP}^{*1}$	—	—	ns	With 16 MHz machine clock $4.5 \text{ V} > AV_{CC} \geq 4.0 \text{ V}$
Analog port input current	$I_{AIN}$	AN0 to AN7	—	—	10	$\mu\text{A}$	
Analog input voltage	$V_{AIN}$	AN0 to AN7	$AV_{SS}$	—	AVR	V	
Reference voltage	—	AVR	$AV_{SS} + 2.7$	—	$AV_{CC}$	V	
Power supply current	$I_A$	$AV_{CC}$	—	3.5	7.5	mA	
	$I_{AH}$	$AV_{CC}$	—	—	5	$\mu\text{A}$	*2
Reference voltage supplying current	$I_R$	AVR	—	165	250	$\mu\text{A}$	
	$I_{RH}$	AVR	—	—	5	$\mu\text{A}$	*2
Variation among channels	—	AN0 to AN7	—	—	4	LSB	

\*1 : Refer to "(1) Clock timing" ratings for  $t_{CP}$  (internal operation clock cycle time).

\*2 : If A/D converter is not operating, a current when CPU is stopped is applicable ( $V_{CC}=AV_{CC}=AVR=5.0 \text{ V}$ ).

## 6. Definition of A/D Converter Terms

- Resolution : Analog variation that is recognized by an A/D converter.
- Linear error : Deviation between a line across zero-transition line (“00 0000 00 0 0” ↔ “00 0000 0001”) and full-scale transition line (“11 1111 11 1 0” ↔ “11 1111 1111”) and actual conversion characteristics.
- Differential linear error : Deviation of input voltage, which is required for changing output code by 1 LSB, from an ideal value.
- Total error : Difference between an actual value and an ideal value. A total error includes zero transition error, full-scale transition error, and linear error.

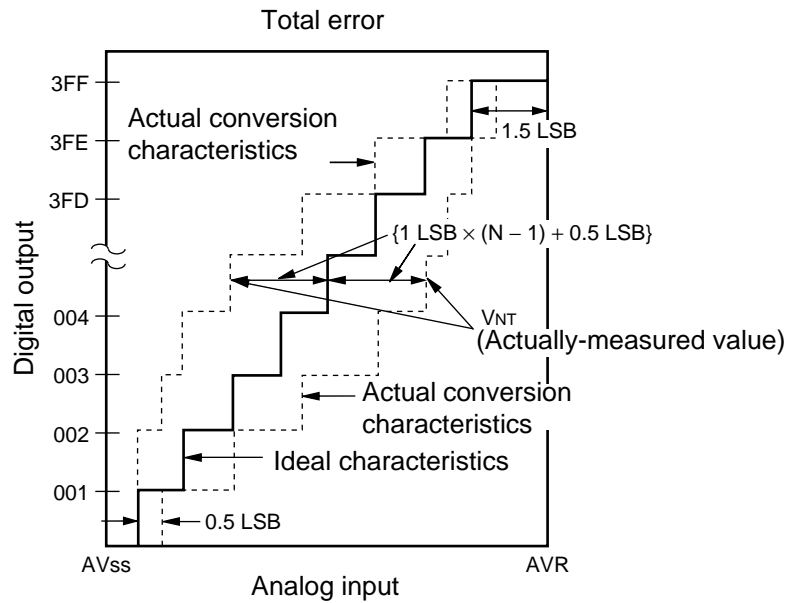

$$\text{Total error of digital output "N"} = \frac{V_{NT} - \{1 \text{ LSB} \times (N - 1) + 0.5 \text{ LSB}\}}{1 \text{ LSB}} \text{ [LSB]}$$

$$1 \text{ LSB} = (\text{Ideal value}) \frac{AVR - AV_{SS}}{1024} \text{ [V]}$$

$$V_{OT} (\text{Ideal value}) = AV_{SS} + 0.5 \text{ LSB [V]}$$

$$V_{FST} (\text{Ideal value}) = AVR - 1.5 \text{ LSB [V]}$$

V<sub>NT</sub> : A voltage at which digital output transits from (N-1) to N.

(Continued)

# MB90385 Series

(Continued)

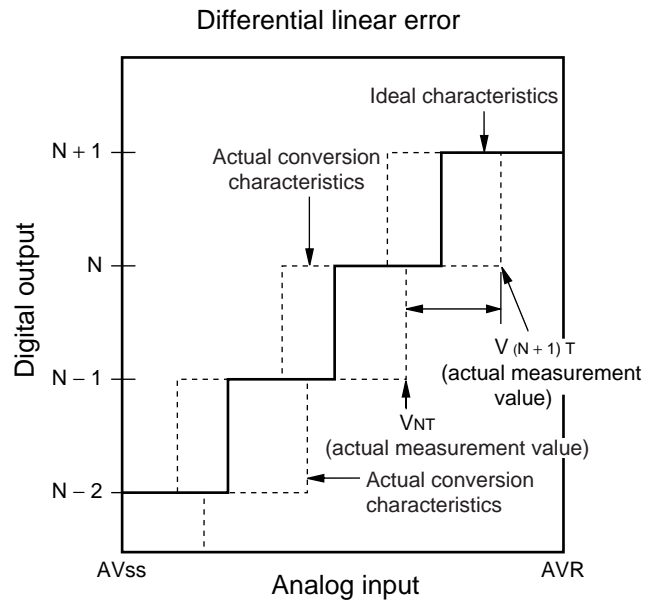
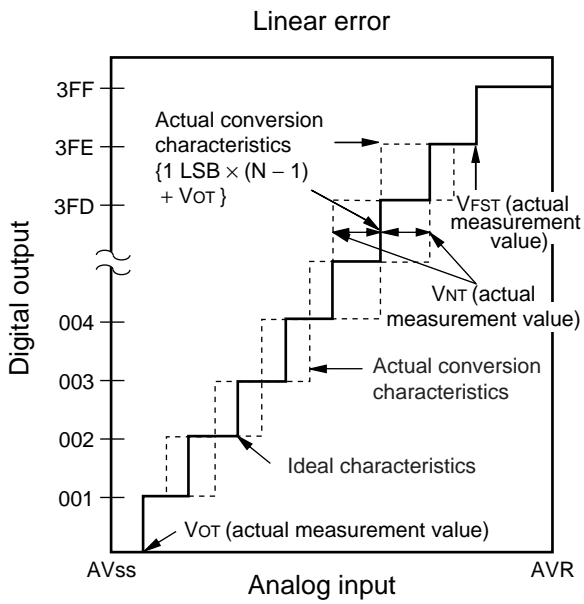

$$\text{Linear error of digital output } N = \frac{V_{NT} - \{1 \text{ LSB} \times (N - 1) + V_{OT}\}}{1 \text{ LSB}} \text{ [LSB]}$$

$$\text{Differential linear error of digital output } N = \frac{V_{(N+1)T} - V_{NT}}{1 \text{ LSB}} - 1 \text{ LSB [LSB]}$$

$$1 \text{ LSB} = \frac{V_{FST} - V_{OT}}{1022} \text{ [V]}$$

$V_{OT}$  : Voltage at which digital output transits from "000H" to "001H."

$V_{FST}$  : Voltage at which digital output transits from "3FEH" to "3FFH."

## 7. Notes on A/D Converter Section

Use the device with external circuits of the following output impedance for analog inputs:

Recommended output impedance of external circuits are: Approx. 3.9 kΩ or lower ( $4.5\text{ V} \leq AV_{CC} \leq 5.5\text{ V}$ ) (sampling period=2.00 μs at 16-MHz machine clock), Approx. 11 kΩ or lower ( $4.0\text{ V} \leq AV_{CC} < 4.5\text{ V}$ ) (sampling period=8.0 μs at 16-MHz machine clock).

If an external capacitor is used, in consideration of the effect by tap capacitance caused by external capacitors and on-chip capacitors, capacitance of the external one is recommended to be several thousand times as high as internal capacitor.

If output impedance of an external circuit is too high, a sampling period for an analog voltage may be insufficient.

### • Analog input circuit model

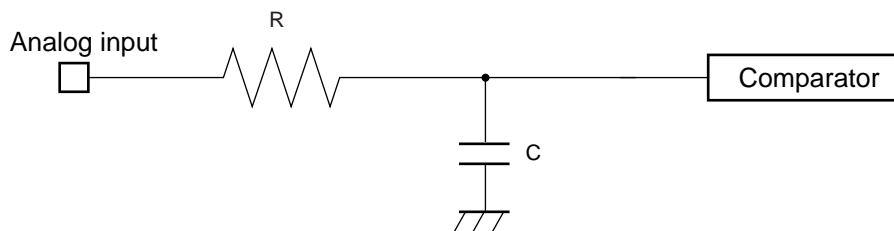

MB90F387/S, MB90387/S

$4.5\text{ V} \leq AV_{CC} \leq 5.5\text{ V}$      $R \approx 2.35\text{ k}\Omega$ ,  $C \approx 36.4\text{ pF}$

$4.0\text{ V} \leq AV_{CC} < 4.5\text{ V}$      $R \approx 16.4\text{ k}\Omega$ ,  $C \approx 36.4\text{ pF}$

Note : Use the values in the figure only as a guideline.

### • About errors

As [AVR-AVss] become smaller, values of relative errors grow larger.

## 8. Flash Memory Program/Erase Characteristics

Parameter	Conditions	Value			Unit	Remarks
		Min	Typ	Max		
Sector eraset time	$T_A = +25\text{ }^\circ\text{C}$ $V_{CC} = 5.0\text{ V}$	—	1	15	s	Excludes 00H programming prior to erasure
Chip erase time		—	4	—	s	Excludes 00H programming prior to erasure
Word (16 bit width) programming time		—	16	3,600	μs	Except for the over head time of the system
Program/Erase cycle	—	10,000	—	—	cycle	
Flash Data Retention Time	Average $T_A = +85\text{ }^\circ\text{C}$	20	—	—	Year	*

\* : This value comes from the technology qualification (using Arrhenius equation to translate high temperature measurements into normalized value at + 85 °C) .

# MB90385 Series

## EXAMPLE CHARACTERISTICS

### MB90F387

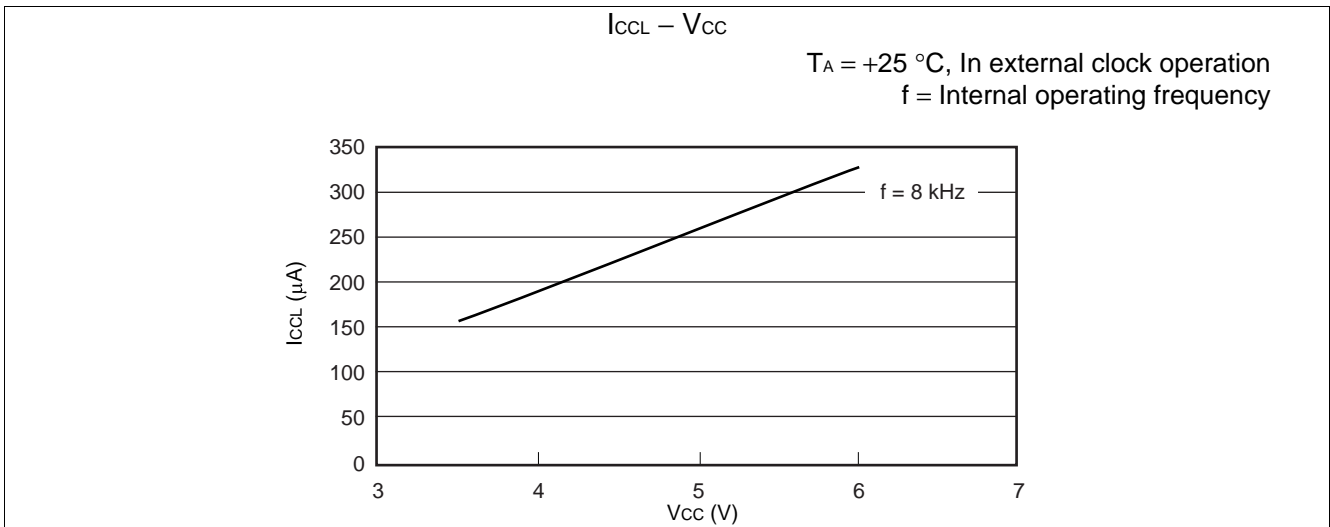
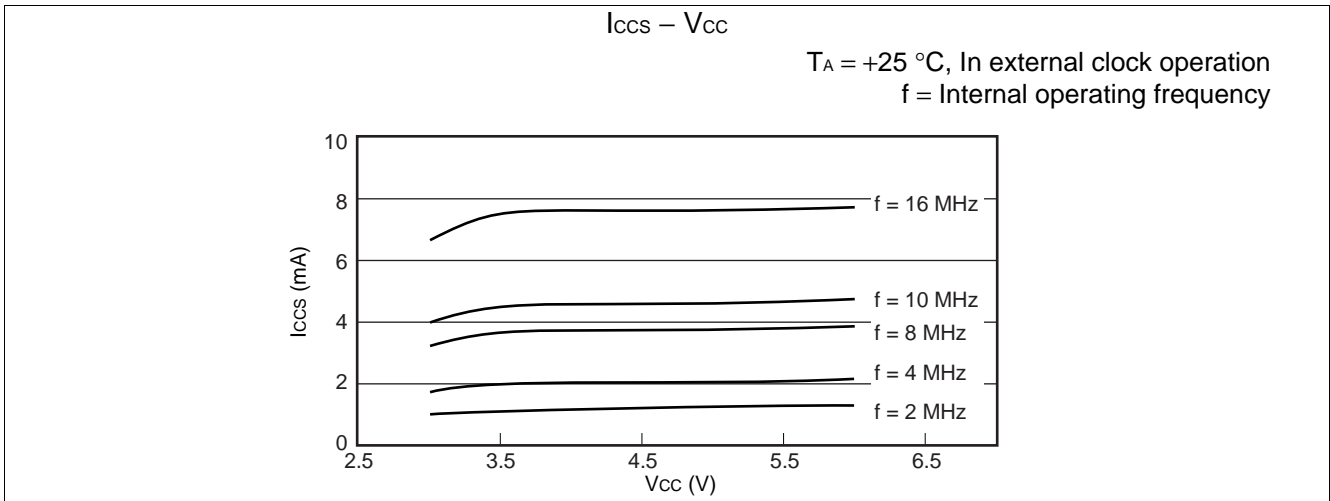
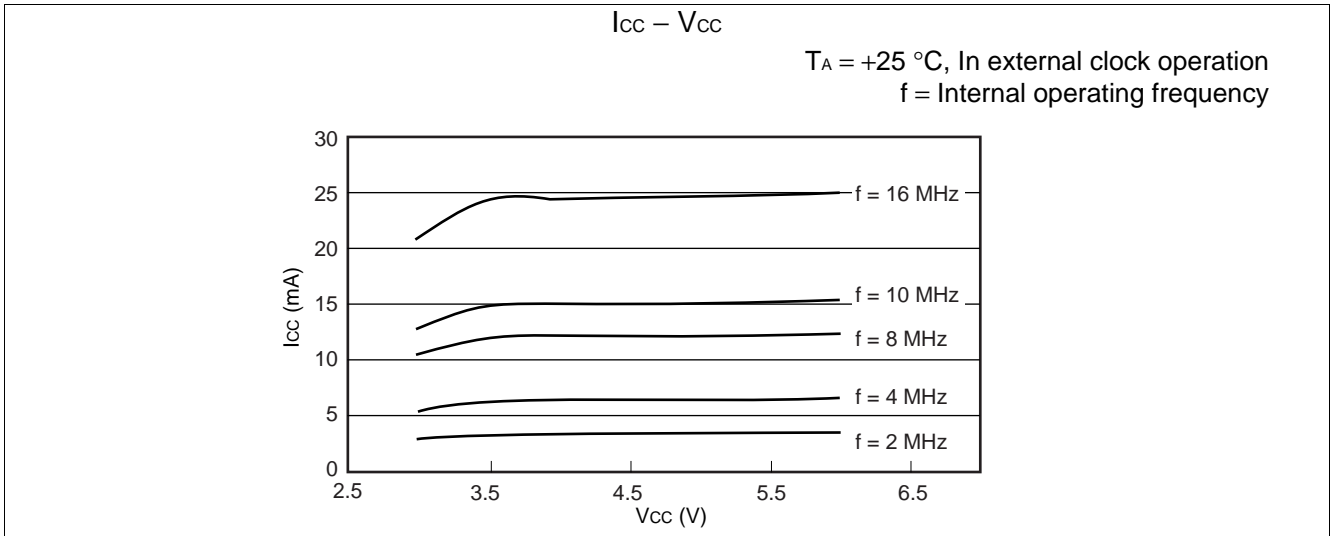

(Continued)

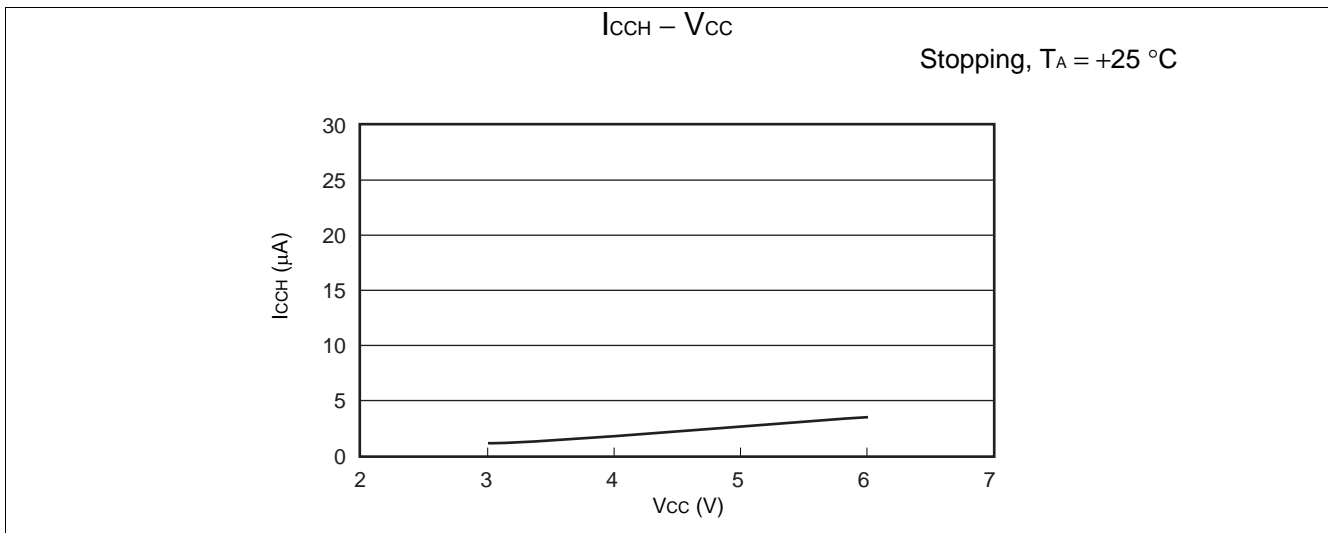
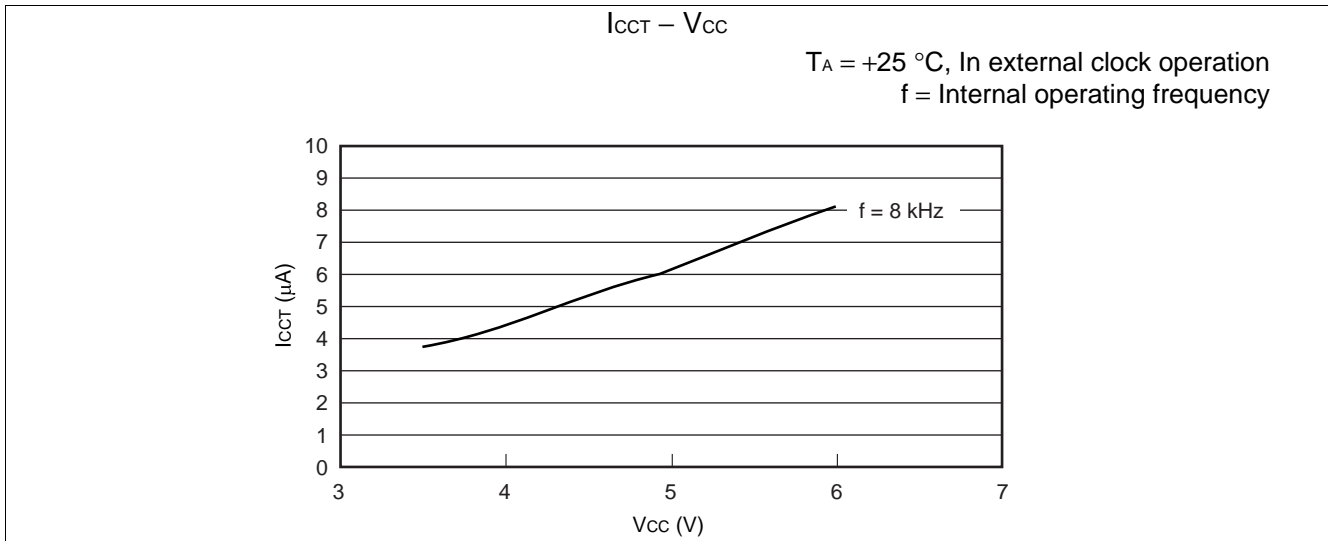
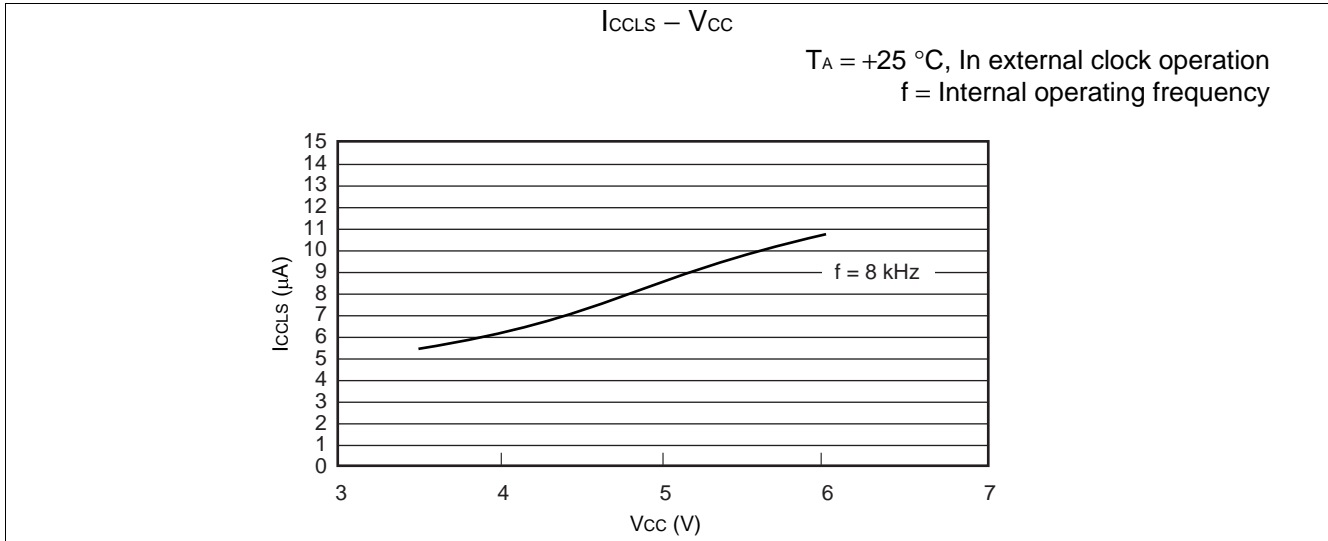

(Continued)

# MB90385 Series

(Continued)

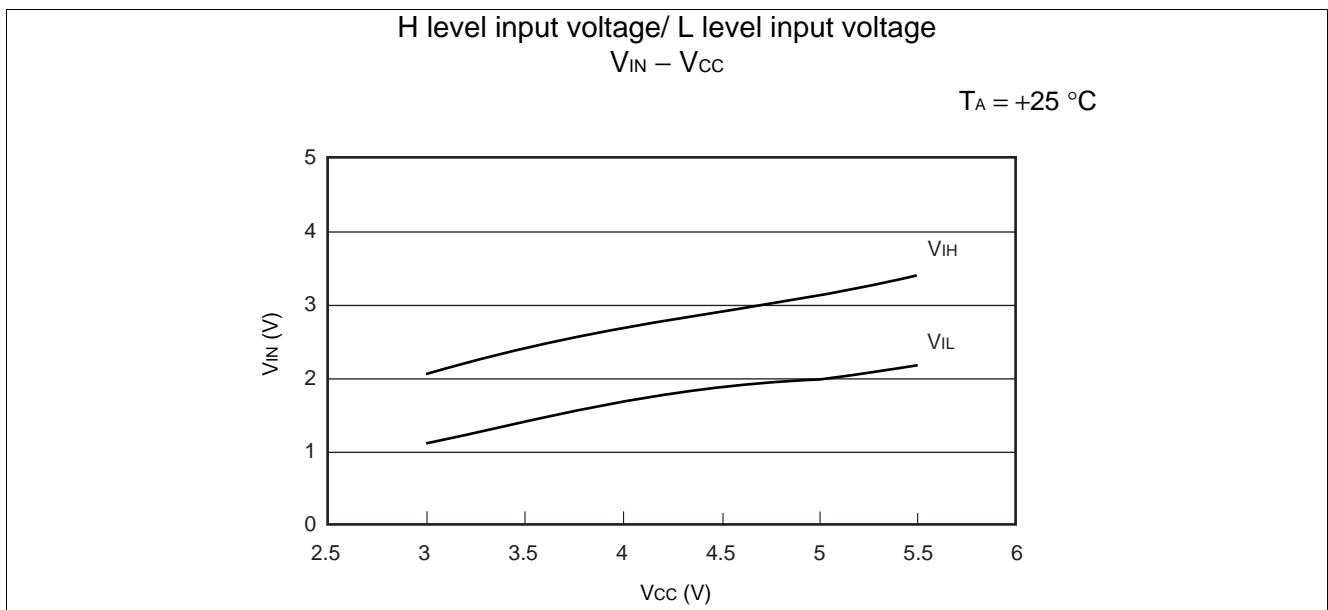
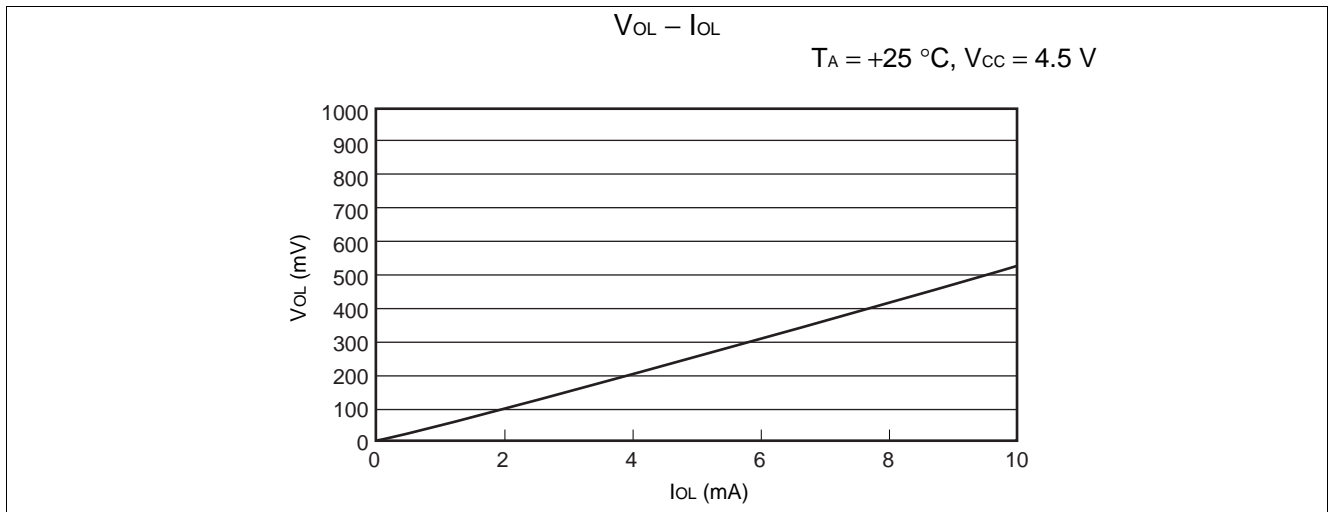
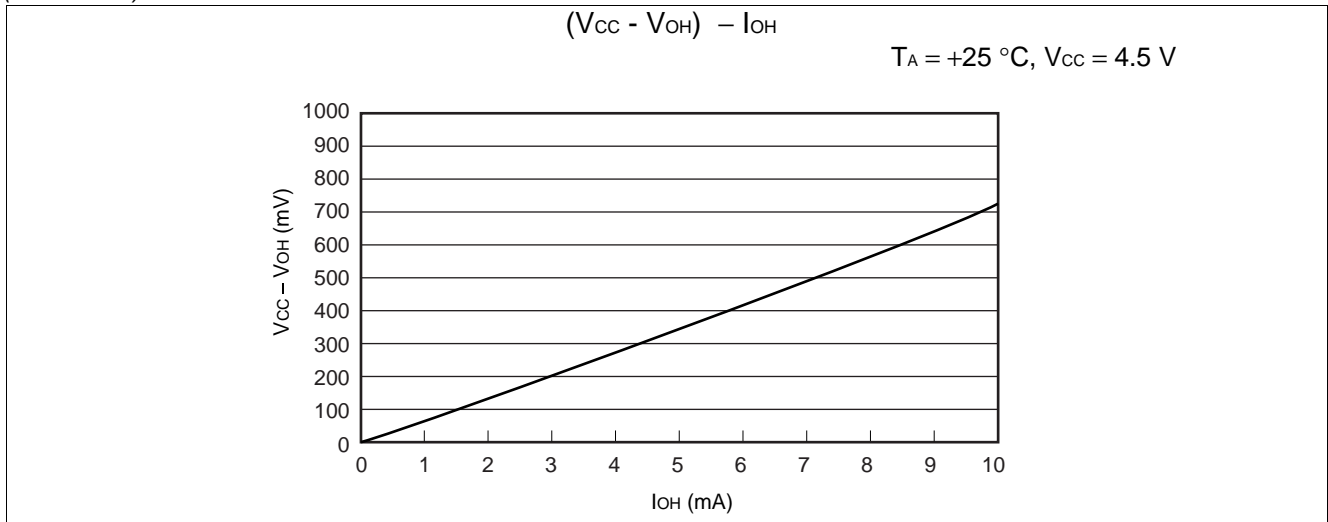

• MB90387

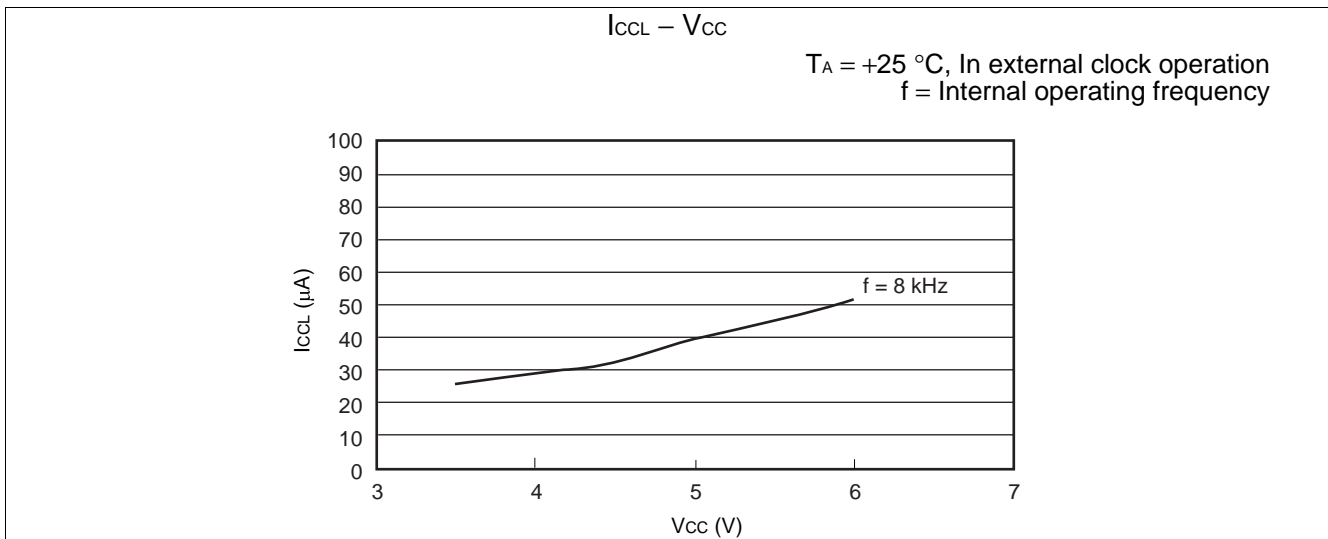
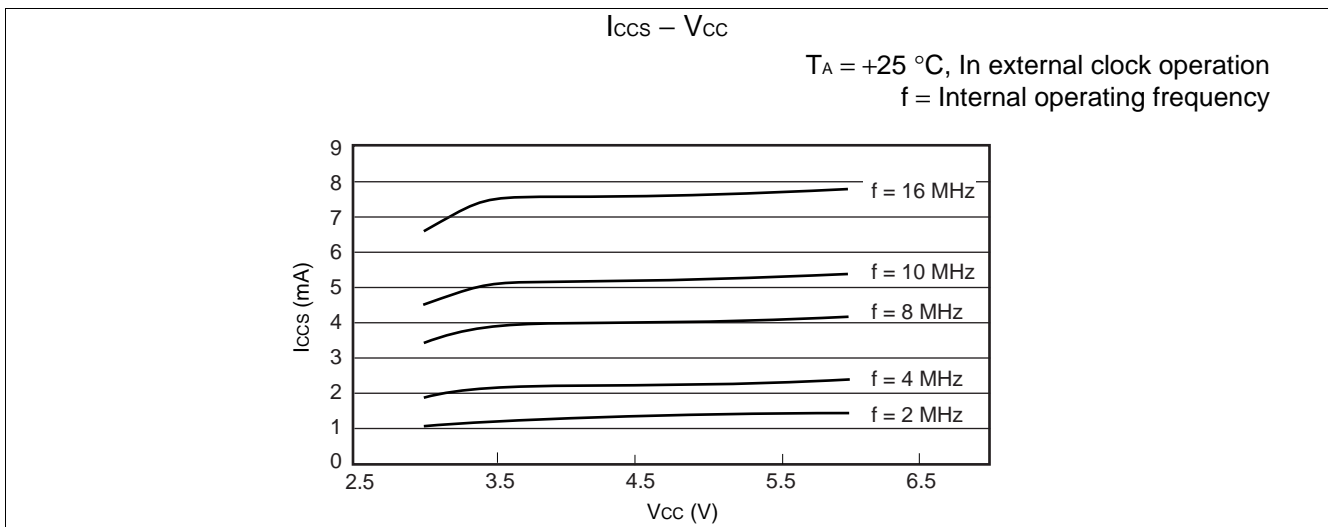
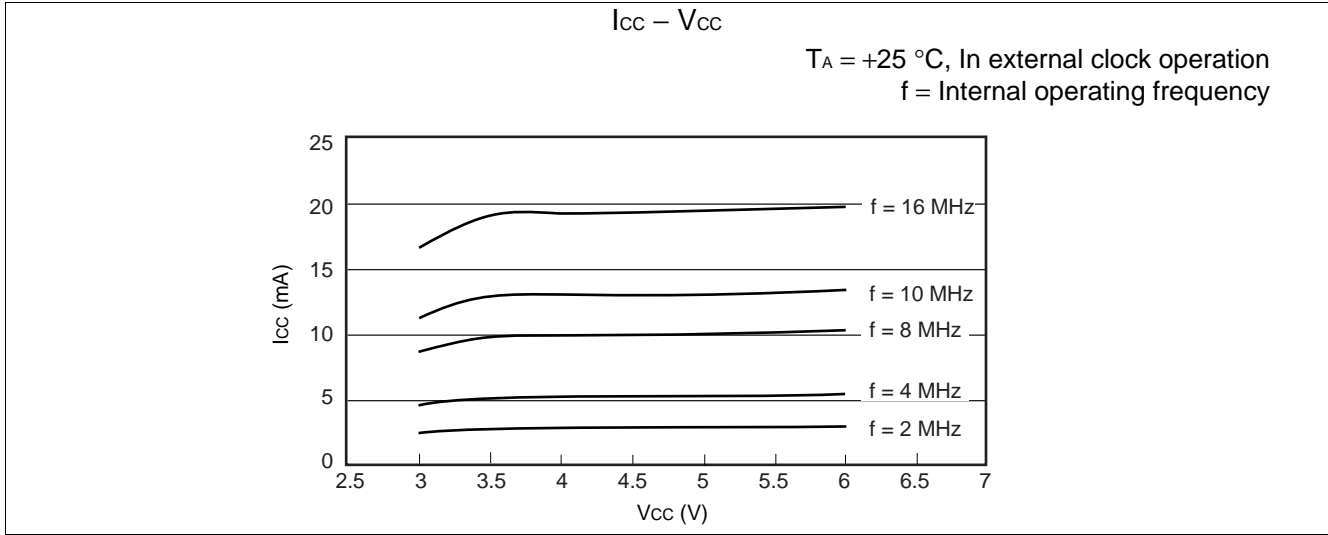

(Continued)

# MB90385 Series

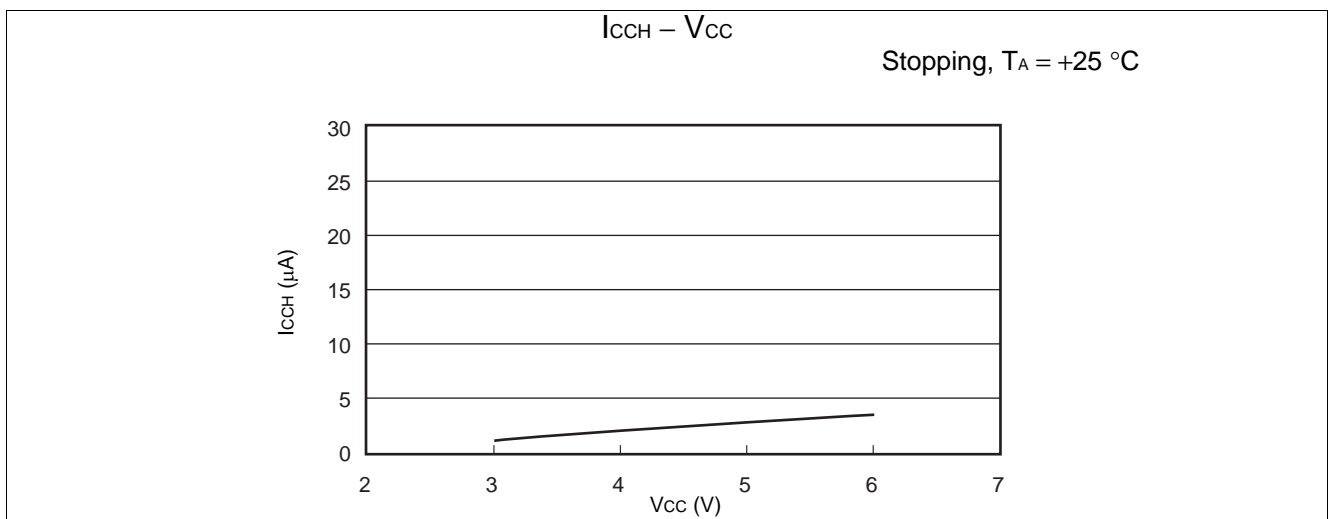
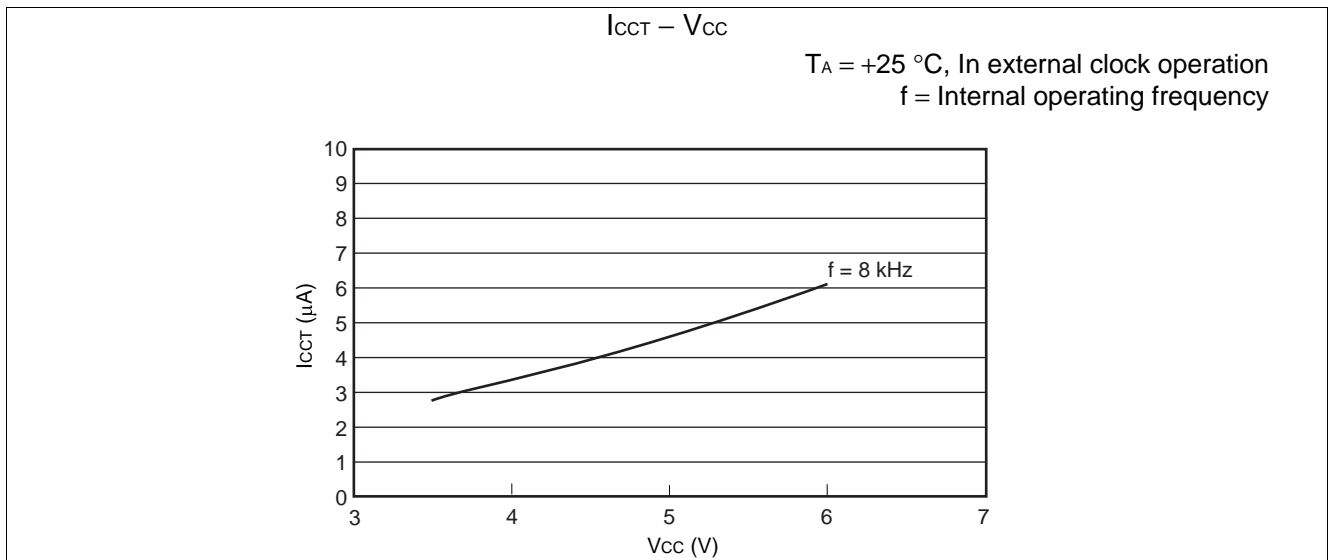
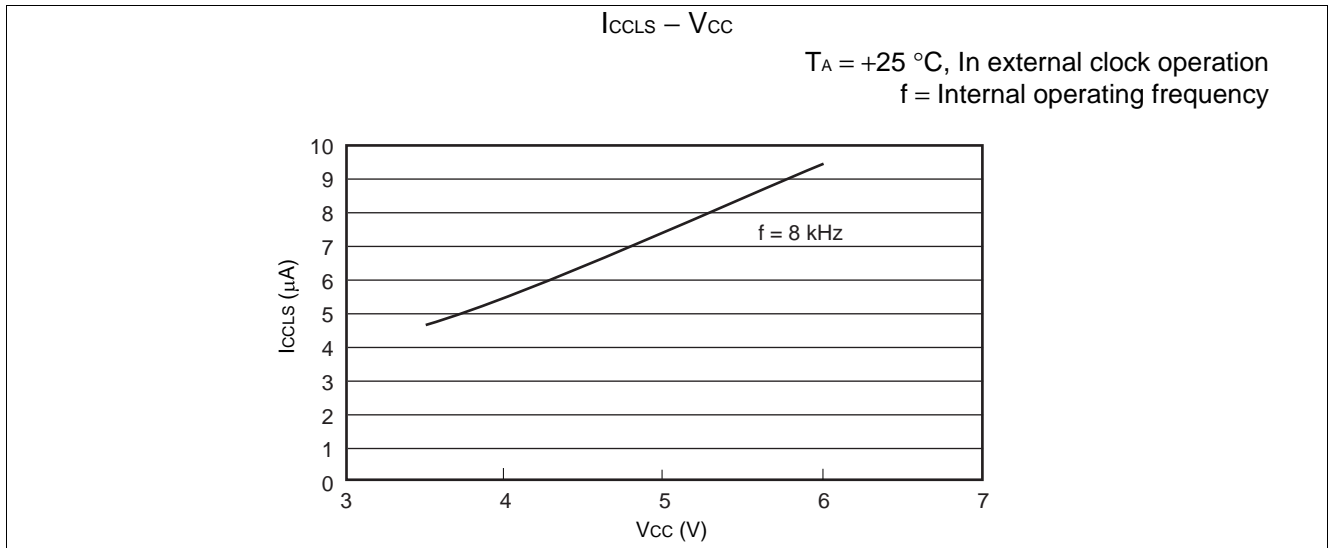

(Continued)

(Continued)

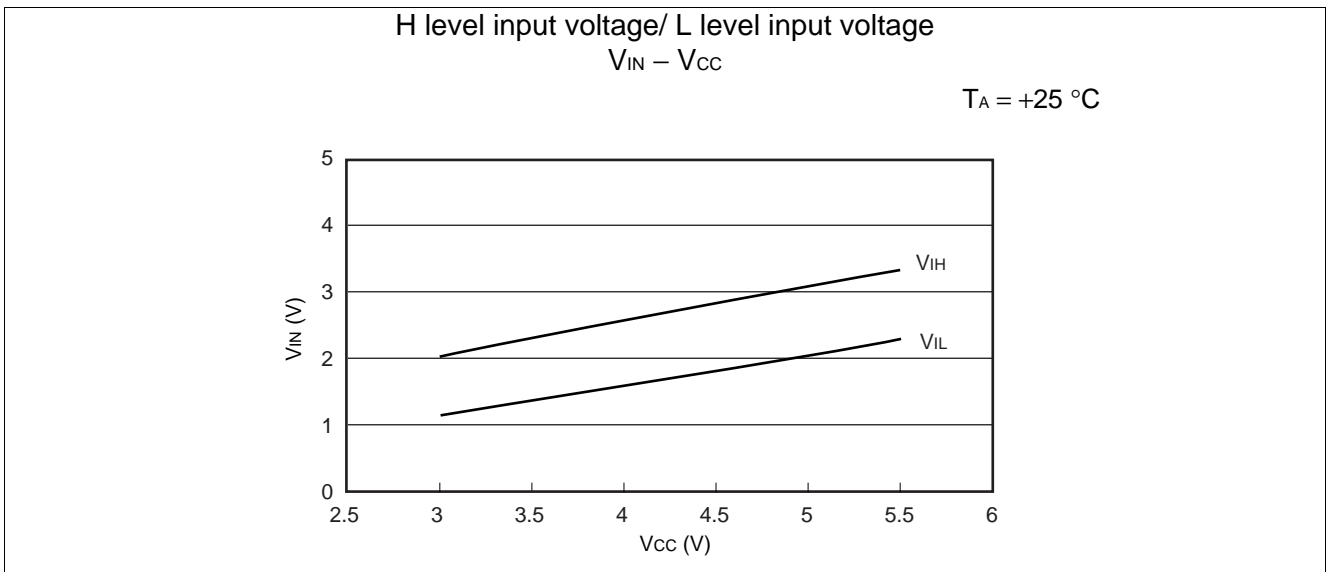
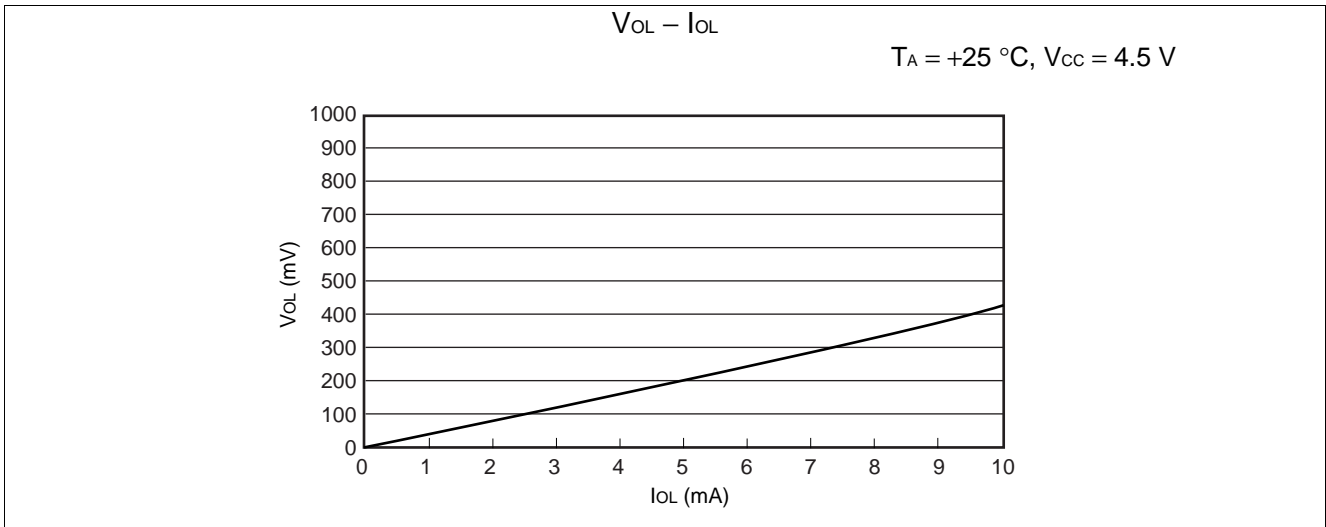
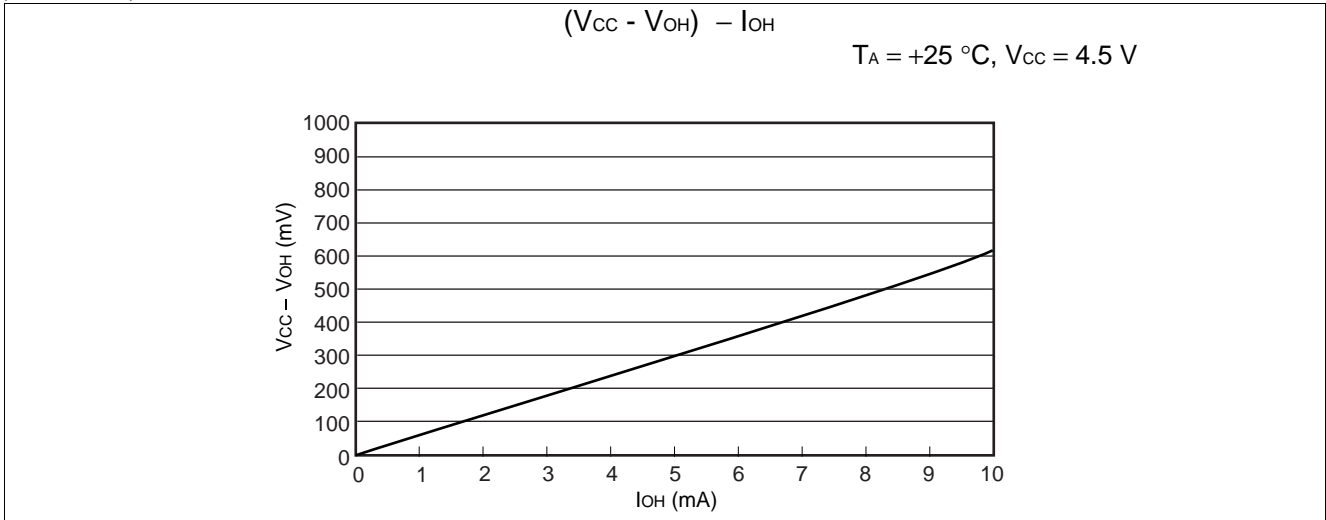

# MB90385 Series

## ■ ORDERING INFORMATION

Part number	Package	Remarks
MB90F387PMT MB90387PMT MB90F387SPMT MB90387SPMT	48-pin plastic LQFP (FPT-48P-M26)	

## ■ PACKAGE DIMENTION

48-pin plastic LQFP  
(FPT-48P-M26)

Note 1) \* : These dimensions include resin protrusion.  
 Note 2) Pins width and pins thickness include plating thickness.  
 Note 3) Pins width do not include tie bar cutting remainder.

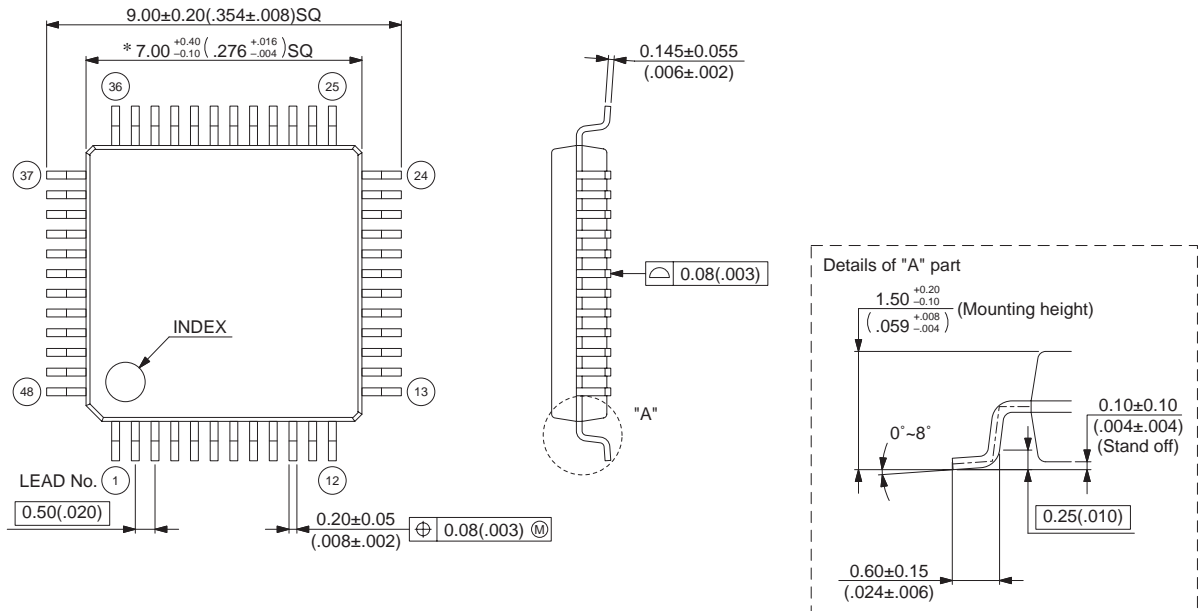

© 2003 FUJITSU LIMITED F48040S-c-2-2

Dimensions in mm (inches)

Note : The values in parentheses are reference values.

## FUJITSU LIMITED

All Rights Reserved.

The contents of this document are subject to change without notice. Customers are advised to consult with FUJITSU sales representatives before ordering.

The information, such as descriptions of function and application circuit examples, in this document are presented solely for the purpose of reference to show examples of operations and uses of Fujitsu semiconductor device; Fujitsu does not warrant proper operation of the device with respect to use based on such information. When you develop equipment incorporating the device based on such information, you must assume any responsibility arising out of such use of the information. Fujitsu assumes no liability for any damages whatsoever arising out of the use of the information.

Any information in this document, including descriptions of function and schematic diagrams, shall not be construed as license of the use or exercise of any intellectual property right, such as patent right or copyright, or any other right of Fujitsu or any third party or does Fujitsu warrant non-infringement of any third-party's intellectual property right or other right by using such information. Fujitsu assumes no liability for any infringement of the intellectual property rights or other rights of third parties which would result from the use of information contained herein.

The products described in this document are designed, developed and manufactured as contemplated for general use, including without limitation, ordinary industrial use, general office use, personal use, and household use, but are not designed, developed and manufactured as contemplated (1) for use accompanying fatal risks or dangers that, unless extremely high safety is secured, could have a serious effect to the public, and could lead directly to death, personal injury, severe physical damage or other loss (i.e., nuclear reaction control in nuclear facility, aircraft flight control, air traffic control, mass transport control, medical life support system, missile launch control in weapon system), or (2) for use requiring extremely high reliability (i.e., submersible repeater and artificial satellite).

Please note that Fujitsu will not be liable against you and/or any third party for any claims or damages arising in connection with above-mentioned uses of the products.

Any semiconductor devices have an inherent chance of failure. You must protect against injury, damage or loss from such failures by incorporating safety design measures into your facility and equipment such as redundancy, fire protection, and prevention of over-current levels and other abnormal operating conditions.

If any products described in this document represent goods or technologies subject to certain restrictions on export under the Foreign Exchange and Foreign Trade Law of Japan, the prior authorization by Japanese government will be required for export of those products from Japan.