

## Features

- EE Programmable 65,536 x 1-, 131,072 x 1-, 262,144 x 1-, 524,288 x 1-, 1,048,576 x 1-, 2,097,152 x 1-, and 4,194,304 x 1-bit Serial Memories Designed to Store Configuration Programs for Field Programmable Gate Arrays (FPGAs)
- Available as a 3.3V ( $\pm 10\%$ ) and 5.0V ( $\pm 5\%$  Commercial,  $\pm 10\%$  Industrial) Version
- In-System Programmable (ISP) via Two-Wire Bus
- Simple Interface to SRAM FPGAs
- Compatible with Atmel AT6000, AT40K and AT94K Devices, Altera FLEX<sup>®</sup>, APEX<sup>™</sup> Devices, Lucent ORCA<sup>®</sup> FPGAs, Xilinx XC3000<sup>™</sup>, XC4000<sup>™</sup>, XC5200<sup>™</sup>, Spartan<sup>®</sup>, Virtex<sup>®</sup> FPGAs
- Cascadable Read-back to Support Additional Configurations or Higher-density Arrays
- Very Low-power CMOS EEPROM Process
- Programmable Reset Polarity
- Available in 6 mm x 6 mm x 1 mm 8-lead LAP (Pin-compatible with 8-lead SOIC/VOIC Packages), 8-lead PDIP, 8-lead SOIC, 20-lead PLCC, 20-lead SOIC, 44-lead PLCC and 44-lead TQFP Packages
- Emulation of Atmel's AT24CXXX Serial EEPROMs
- Low-power Standby Mode
- High-reliability
  - Endurance: 100,000 Write Cycles
  - Data Retention: 90 Years for Industrial Parts (at 85°C) and 190 Years for Commercial Parts (at 70°C)

## Description

The AT17LV series FPGA Configuration EEPROMs (Configurators) provide an easy-to-use, cost-effective configuration memory for Field Programmable Gate Arrays. The AT17LV series device is packaged in the 8-lead LAP, 8-lead PDIP, 8-lead SOIC, 20-lead PLCC, 20-lead SOIC, 44-lead PLCC and 44-lead TQFP, see Table 1. The AT17LV series Configurators uses a simple serial-access procedure to configure one or more FPGA devices. The user can select the polarity of the reset function by programming four EEPROM bytes. These devices also support a write-protection mechanism within its programming mode.

The AT17LV series configurators can be programmed with industry-standard programmers, Atmel's ATDH2200E Programming Kit or Atmel's ATDH2225 ISP Cable.

**Table 1.** AT17LV Series Packages

Package	AT17LV65/ AT17LV128/ AT17LV256	AT17LV512/ AT17LV010	AT17LV002	AT17LV040
8-lead LAP	Yes	Yes	Yes	(3)
8-lead PDIP	Yes	Yes	–	–
8-lead SOIC	Yes	Use 8-lead LAP <sup>(1)</sup>	Use 8-lead LAP <sup>(1)</sup>	(3)
20-lead PLCC	Yes	Yes	Yes	–
20-lead SOIC	Yes <sup>(2)</sup>	Yes <sup>(2)</sup>	Yes <sup>(2)</sup>	–
44-lead PLCC	–	–	Yes	Yes
44-lead TQFP	–	–	Yes	Yes

- Notes:
1. The 8-lead LAP package has the same footprint as the 8-lead SOIC. Since an 8-lead SOIC package is not available for the AT17LV512/010/002 devices, it is possible to use an 8-lead LAP package instead.
  2. The pinout for the AT17LV65/128/256 devices is not pin-for-pin compatible with the AT17LV512/010/002 devices.
  3. Refer to the AT17Fxxx datasheet, available on the Atmel web site.



## FPGA Configuration EEPROM Memory

AT17LV65  
AT17LV128  
AT17LV256  
AT17LV512  
AT17LV010  
AT17LV002  
AT17LV040

## 3.3V and 5V System Support



## Pin Configuration

### 8-lead LAP

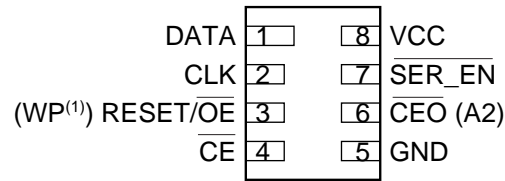

### 8-lead SOIC

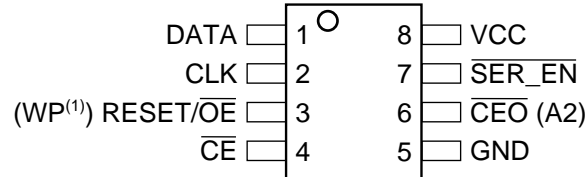

### 8-lead PDIP

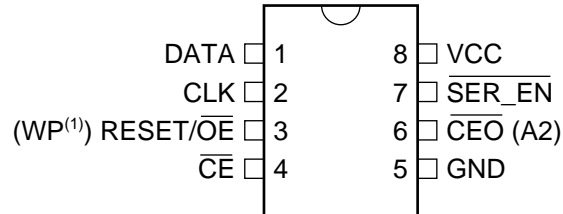

### 20-lead PLCC

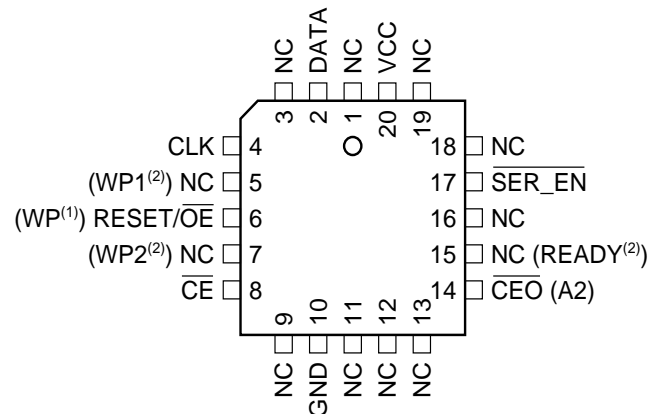

- Notes: 1. This pin is only available on AT17LV65/128/256 devices.  
 2. This pin is only available on AT17LV512/010/002 devices.

## 20-lead SOIC<sup>(1)</sup>

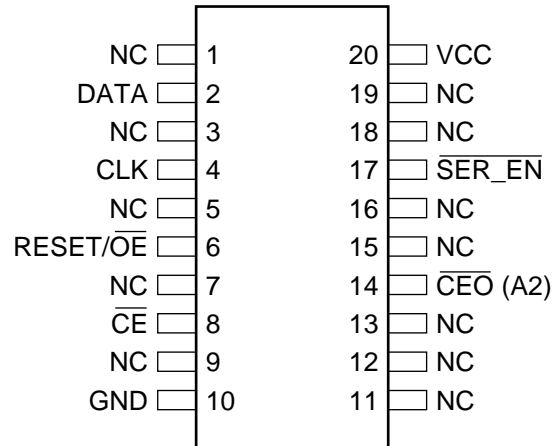

Note: 1. This pinout only applies to AT17LV65/128/256 devices.

## 20-lead SOIC<sup>(1)</sup>

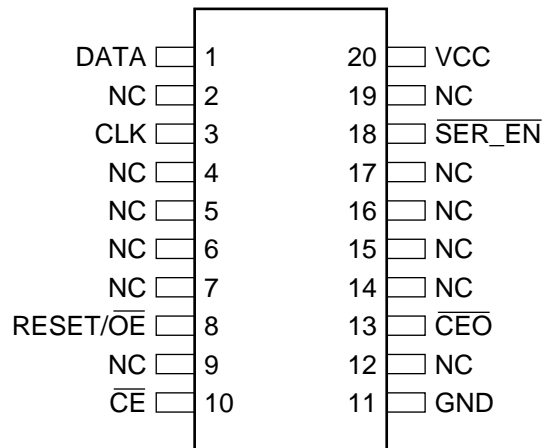

Note: 1. This pinout only applies to AT17LV512/010/002 devices.



### 44 PLCC

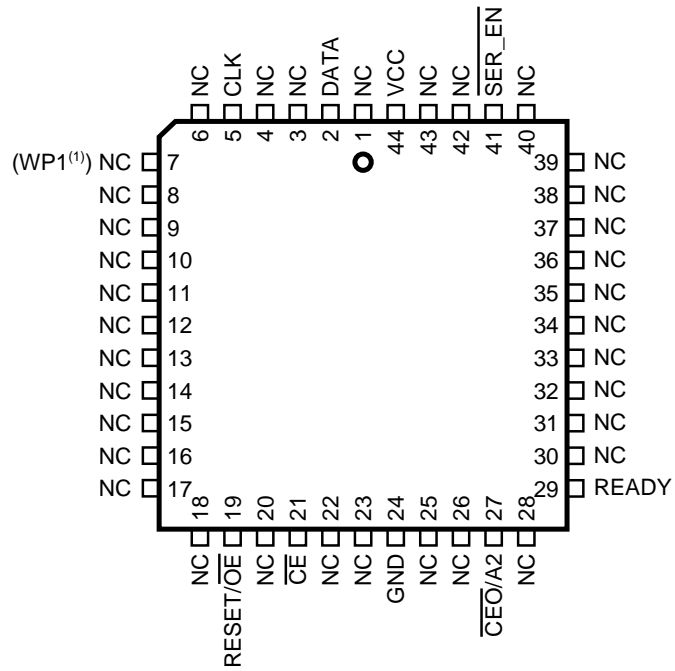

### 44 TQFP

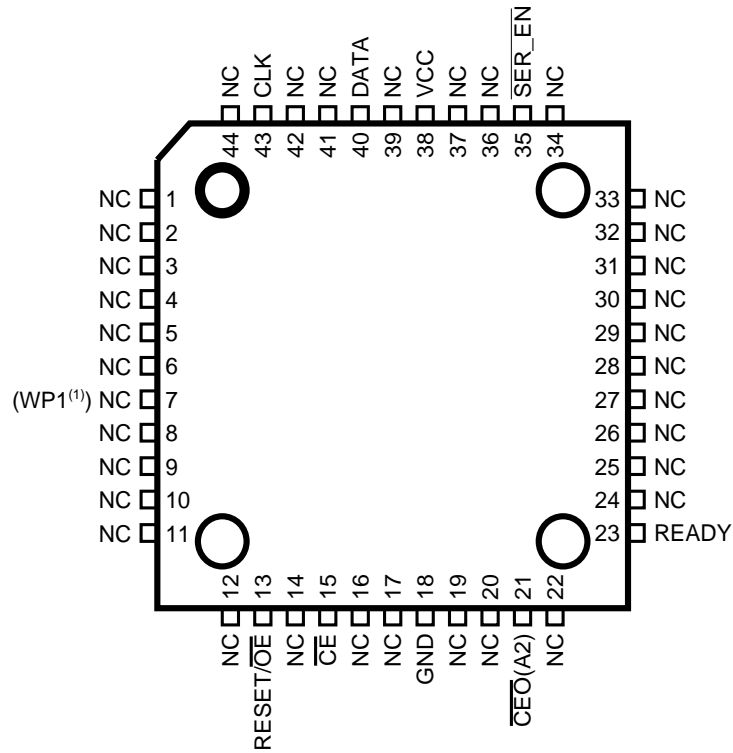

Note: 1. This pin is only available on AT17LV002 devices.

## Block Diagram

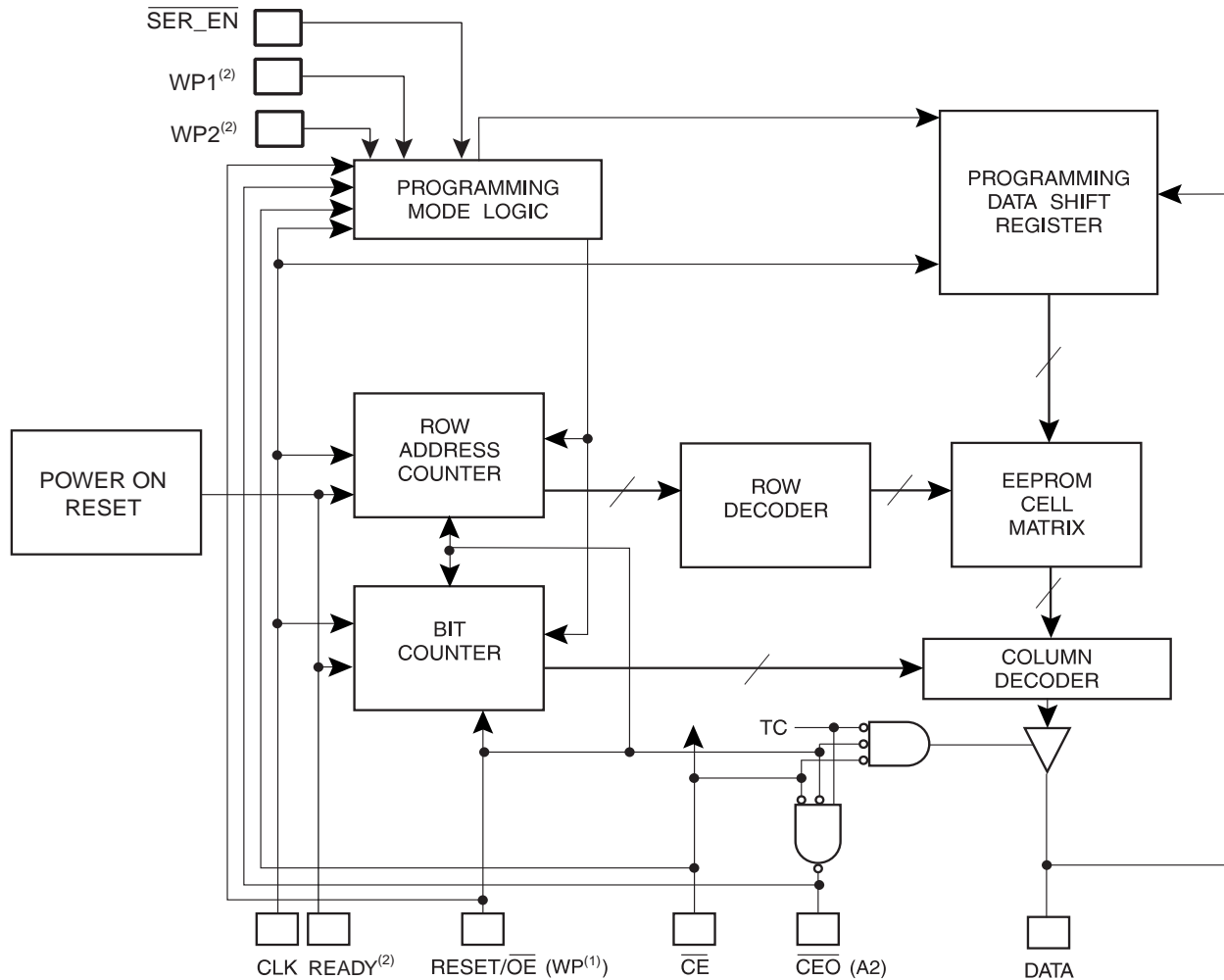

- Notes: 1. This pin is only available on AT17LV65/128/256 devices.  
 2. This pin is only available on AT17LV512/010/002 devices.

## Device Description

The control signals for the configuration EEPROM ( $\overline{CE}$ ,  $\overline{RESET/OE}$  and  $CCLK$ ) interface directly with the FPGA device control signals. All FPGA devices can control the entire configuration process and retrieve data from the configuration EEPROM without requiring an external intelligent controller.

The configuration EEPROM  $\overline{RESET/OE}$  and  $\overline{CE}$  pins control the tri-state buffer on the DATA output pin and enable the address counter. When  $\overline{RESET/OE}$  is driven High, the configuration EEPROM resets its address counter and tri-states its DATA pin. The  $\overline{CE}$  pin also controls the output of the AT17LV series configurator. If  $\overline{CE}$  is held High after the  $\overline{RESET/OE}$  reset pulse, the counter is disabled and the DATA output pin is tri-stated. When  $\overline{OE}$  is subsequently driven Low, the counter and the DATA output pin are enabled. When  $\overline{RESET/OE}$  is driven High again, the address counter is reset and the DATA output pin is tri-stated, regardless of the state of  $\overline{CE}$ .

When the configurator has driven out all of its data and  $\overline{CEO}$  is driven Low, the device tri-states the DATA pin to avoid contention with other configurators. Upon power-up, the address counter is automatically reset.

This is the default setting for the device. Since almost all FPGAs use RESET Low and OE High, this document will describe  $\overline{RESET/OE}$ .

## Pin Description

Name	I/O	AT17LV65/ AT17LV128/ AT17LV256			AT17LV512/ AT17LV010			AT17LV002				AT17LV040		
		8 DIP/ LAP/ SOIC	20 PLCC	20 SOIC	8 DIP/ LAP	20 PLCC	20 SOIC	8 DIP/ LAP/ SOIC	20 PLCC	20 SOIC	44 PLCC	44 TQFP	44 PLCC	44 TQFP
DATA	I/ O	1	2	2	1	2	1	1	2	1	2	40	2	40
CLK	I	2	4	4	2	4	3	2	4	3	5	43	5	43
WP1	I	–	–	–	–	5	–	–	5	–	–	–	–	–
RESET/OE	I	3	6	6	3	6	8	3	6	8	19	13	19	13
WP2	I				–	7	–	–	7	–	–	–	–	–
$\overline{CE}$	I	4	8	8	4	8	10	4	8	10	21	15	21	15
GND		5	10	10	5	10	11	5	10	11	24	18	24	18
$\overline{CEO}$	O						13				13			
A2	I	6	14	14	6	14	–	6	14	–	27	21	27	21
READY	O	–	–	–	–	15	–	–	15	–	29	23	29	23
$\overline{SER\_EN}$	I	7	17	17	7	17	18	7	17	18	41	35	41	35
V <sub>CC</sub>		8	20	20	8	20	20	8	20	20	44	38	44	38

### DATA

Three-state DATA output for configuration. Open-collector bi-directional pin for programming.

### CLK

Clock input. Used to increment the internal address and bit counter for reading and programming.

### WP1

WRITE PROTECT (1). Used to protect portions of memory during programming. Disabled by default due to internal pull-down resistor. This input pin is not used during FPGA loading operations. This pin is only available on AT17LV512/010/002 devices.

### RESET/OE

Output Enable (active High) and RESET (active Low) when  $\overline{SER\_EN}$  is High. A Low level on  $\overline{RESET/OE}$  resets both the address and bit counters. A High level (with  $\overline{CE}$  Low) enables the data output driver. The logic polarity of this input is programmable as either  $\overline{RESET/OE}$  or  $\overline{RESET/OE}$ . For most applications, RESET should be programmed active Low. This document describes the pin as  $\overline{RESET/OE}$ .

### WP

Write protect (WP) input (when  $\overline{CE}$  is Low) during programming only ( $\overline{SER\_EN}$  Low). When WP is Low, the entire memory can be written. When WP is enabled (High), the lowest block of the memory cannot be written. This pin is only available on AT17LV65/128/256 devices.

### WP2

WRITE PROTECT (2). Used to protect portions of memory during programming. Disabled by default due to internal pull-down resistor. This input pin is not used during FPGA loading operations. This pin is only available on AT17LV512/010 devices.

<b><math>\overline{\text{CE}}</math></b>	Chip Enable input (active Low). A Low level (with OE High) allows CLK to increment the address counter and enables the data output driver. A High level on $\overline{\text{CE}}$ disables both the address and bit counters and forces the device into a low-power standby mode. Note that this pin will <i>not</i> enable/disable the device in the Two-Wire Serial Programming mode (SER_EN Low).
<b>GND</b>	Ground pin. A 0.2 $\mu\text{F}$ decoupling capacitor between $V_{\text{CC}}$ and GND is recommended.
<b><math>\overline{\text{CEO}}</math></b>	Chip Enable Output (active Low). This output goes Low when the address counter has reached its maximum value. In a daisy chain of AT17LV series devices, the $\overline{\text{CEO}}$ pin of one device must be connected to the $\overline{\text{CE}}$ input of the next device in the chain. It will stay Low as long as $\overline{\text{CE}}$ is Low and OE is High. It will then follow CE until OE goes Low; thereafter, $\overline{\text{CEO}}$ will stay High until the entire EEPROM is read again.
<b>A2</b>	Device selection input, A2. This is used to enable (or select) the device during programming (i.e., when SER_EN is Low). A2 has an internal pull-down resistor.
<b>READY</b>	Open collector reset state indicator. Driven Low during power-up reset, released when power-up is complete. It is recommended to use a 4.7 k $\Omega$ pull-up resistor when this pin is used.
<b><math>\overline{\text{SER\_EN}}</math></b>	Serial enable must be held High during FPGA loading operations. Bringing $\overline{\text{SER\_EN}}$ Low enables the Two-Wire Serial Programming Mode. For non-ISP applications, $\overline{\text{SER\_EN}}$ should be tied to $V_{\text{CC}}$ .
<b><math>V_{\text{CC}}</math></b>	3.3V ( $\pm 10\%$ ) and 5.0V ( $\pm 5\%$ Commercial, $\pm 10\%$ Industrial) power supply pin.



## FPGA Master Serial Mode Summary

The I/O and logic functions of any SRAM-based FPGA are established by a configuration program. The program is loaded either automatically upon power-up, or on command, depending on the state of the FPGA mode pins. In Master mode, the FPGA automatically loads the configuration program from an external memory. The AT17LV Serial Configuration EEPROM has been designed for compatibility with the Master Serial mode.

This document discusses the Atmel AT40K, AT40KAL and AT94KAL applications as well as Xilinx applications.

## Control of Configuration

Most connections between the FPGA device and the AT17LV Serial EEPROM are simple and self-explanatory.

- The DATA output of the AT17LV series configurator drives DIN of the FPGA devices.
- The master FPGA CCLK output drives the CLK input of the AT17LV series configurator.
- The  $\overline{\text{CEO}}$  output of any AT17LV series configurator drives the  $\overline{\text{CE}}$  input of the next configurator in a cascaded chain of EEPROMs.
- $\overline{\text{SER\_EN}}$  must be connected to  $V_{\text{CC}}$  (except during ISP).
- The  $\text{READY}^{(1)}$  pin is available as an open-collector indicator of the device's reset status; it is driven Low while the device is in its power-on reset cycle and released (tri-stated) when the cycle is complete.

Note: 1. This pin is not available for the AT17LV65/128/256 devices.

## Cascading Serial Configuration EEPROMs

For multiple FPGAs configured as a daisy-chain, or for FPGAs requiring larger configuration memories, cascaded configurators provide additional memory.

After the last bit from the first configurator is read, the clock signal to the configurator asserts its  $\overline{\text{CEO}}$  output Low and disables its DATA line driver. The second configurator recognizes the Low level on its  $\overline{\text{CE}}$  input and enables its DATA output.

After configuration is complete, the address counters of all cascaded configurators are reset if the  $\overline{\text{RESET/OE}}$  on each configurator is driven to its active (Low) level.

If the address counters are not to be reset upon completion, then the  $\overline{\text{RESET/OE}}$  input can be tied to its inactive (High) level.

## AT17LV Series Reset Polarity

The AT17LV series configurator allows the user to program the reset polarity as either  $\overline{\text{RESET/OE}}$  or  $\text{RESET/OE}$ . This feature is supported by industry-standard programmer algorithms.

## Programming Mode

The programming mode is entered by bringing  $\overline{\text{SER\_EN}}$  Low. In this mode the chip can be programmed by the Two-Wire serial bus. The programming is done at  $V_{\text{CC}}$  supply only. Programming super voltages are generated inside the chip.

## Standby Mode

The AT17LV series configurators enter a low-power standby mode whenever  $\overline{\text{CE}}$  is asserted High. In this mode, the AT17LV65/128/256 configurator consumes less than 50  $\mu\text{A}$  of current at 3.3V (100  $\mu\text{A}$  for the AT17LV512/010 and 200  $\mu\text{A}$  for the AT17LV002/040). The output remains in a high-impedance state regardless of the state of the  $\overline{\text{OE}}$  input.

### Absolute Maximum Ratings\*

Operating Temperature.....	-40°C to +85°C
Storage Temperature .....	-65°C to +150°C
Voltage on Any Pin with Respect to Ground .....	-0.1V to $V_{CC} + 0.5V$
Supply Voltage ( $V_{CC}$ ) .....	-0.5V to +7.0V
Maximum Soldering Temp. (10 sec. @ 1/16 in.).....	260°C
ESD ( $R_{ZAP} = 1.5K, C_{ZAP} = 100 \text{ pF}$ ).....	2000V

\*NOTICE: Stresses beyond those listed under Absolute Maximum Ratings may cause permanent damage to the device. This is a stress rating only and functional operation of the device at these or any other conditions beyond those listed under operating conditions is not implied. Exposure to Absolute Maximum Rating conditions for extended periods of time may affect device reliability.

### Operating Conditions

Symbol	Description		3.3V		5V		Units
			Min	Max	Min	Max	
$V_{CC}$	Commercial	Supply voltage relative to GND -0°C to +70°C	3.0	3.6	4.75	5.25	V
	Industrial	Supply voltage relative to GND -40°C to +85°C	3.0	3.6	4.5	5.5	V



## DC Characteristics

$V_{CC} = 3.3V \pm 10\%$

Symbol	Description	AT17LV65/ AT17LV128/ AT17LV256		AT17LV512/ AT17LV010		AT17LV002/ AT17LV040		Units
		Min	Max	Min	Max	Min	Max	
$V_{IH}$	High-level Input Voltage	2.0	$V_{CC}$	2.0	$V_{CC}$	2.0	$V_{CC}$	V
$V_{IL}$	Low-level Input Voltage	0	0.8	0	0.8	0	0.8	V
$V_{OH}$	High-level Output Voltage ( $I_{OH} = -2.5$ mA)	2.4		2.4		2.4		V
$V_{OL}$	Low-level Output Voltage ( $I_{OL} = +3$ mA)							
$V_{OH}$	High-level Output Voltage ( $I_{OH} = -2$ mA)	2.4		2.4		2.4		V
$V_{OL}$	Low-level Output Voltage ( $I_{OL} = +3$ mA)							
$I_{CCA}$	Supply Current, Active Mode		5		5		5	mA
$I_L$	Input or Output Leakage Current ( $V_{IN} = V_{CC}$ or GND)	-10	10	-10	10	-10	10	$\mu$ A
$I_{CCS}$	Supply Current, Standby Mode	Commercial	50	100	150	$\mu$ A		
		Industrial	100	100	150	$\mu$ A		

## DC Characteristics

$V_{CC} = 5V \pm 5\%$  Commercial;  $V_{CC} = 5V \pm 10\%$  Industrial

Symbol	Description	AT17LV65/ AT17LV128/ AT17LV256		AT17LV512/ AT17LV010		AT17LV002/ AT17LV040		Units
		Min	Max	Min	Max	Min	Max	
$V_{IH}$	High-level Input Voltage	2.0	$V_{CC}$	2.0	$V_{CC}$	2.0	$V_{CC}$	V
$V_{IL}$	Low-level Input Voltage	0	0.8	0	0.8	0	0.8	V
$V_{OH}$	High-level Output Voltage ( $I_{OH} = -2.5$ mA)	3.7		3.86		3.86		V
$V_{OL}$	Low-level Output Voltage ( $I_{OL} = +3$ mA)							
$V_{OH}$	High-level Output Voltage ( $I_{OH} = -2$ mA)	3.6		3.76		3.76		V
$V_{OL}$	Low-level Output Voltage ( $I_{OL} = +3$ mA)							
$I_{CCA}$	Supply Current, Active Mode		10		10		10	mA
$I_L$	Input or Output Leakage Current ( $V_{IN} = V_{CC}$ or GND)	-10	10	-10	10	-10	10	$\mu$ A
$I_{CCS}$	Supply Current, Standby Mode	Commercial	75	200	350	$\mu$ A		
		Industrial	150	200	350	$\mu$ A		

### AC Characteristics

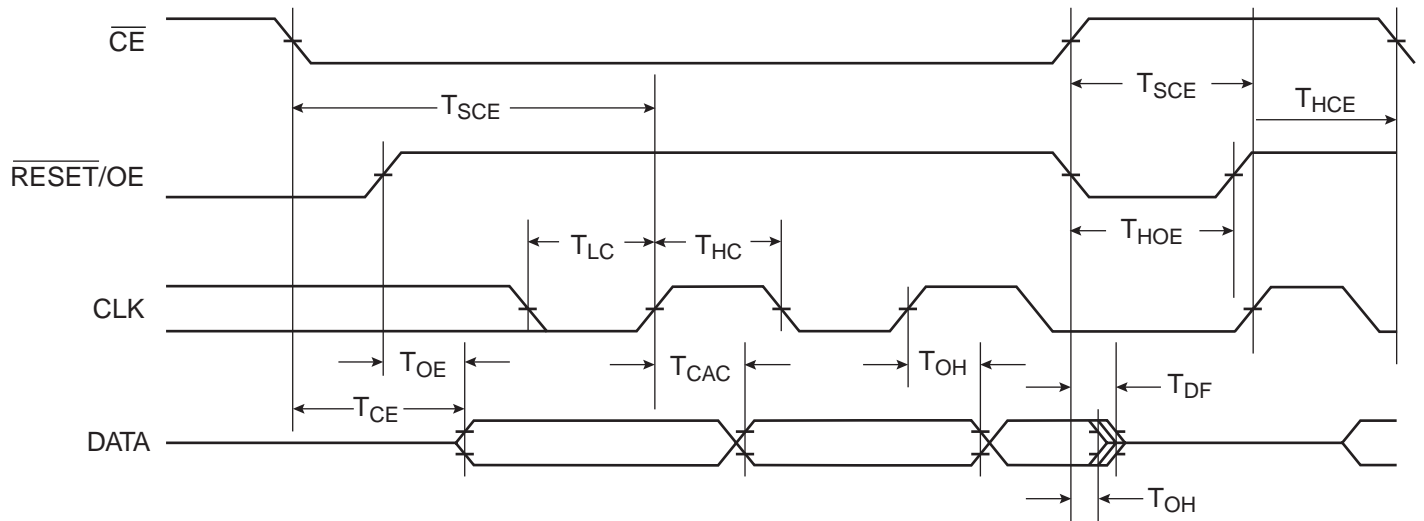

### AC Characteristics when Cascading

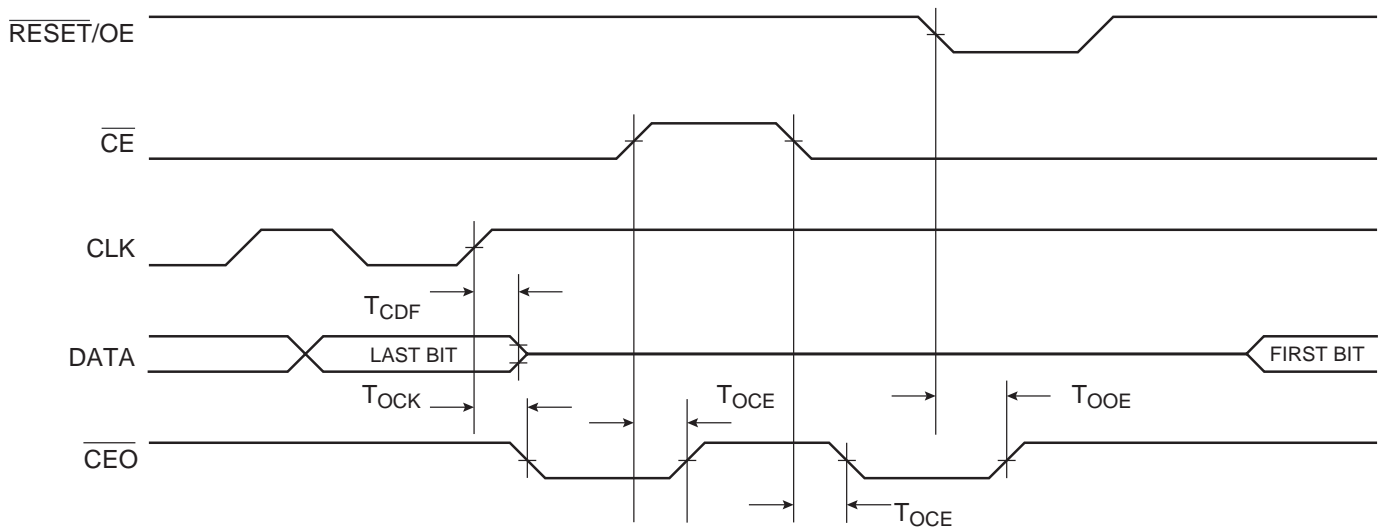



## AC Characteristics

$$V_{CC} = 3.3V \pm 10\%$$

Symbol	Description	AT17LV65/128/256				AT17LV512/010/002/040				Units
		Commercial		Industrial		Commercial		Industrial		
		Min	Max	Min	Max	Min	Max	Min	Max	
$T_{OE}^{(1)}$	OE to Data Delay		50		55		50		55	ns
$T_{CE}^{(1)}$	$\overline{CE}$ to Data Delay		60		60		55		60	ns
$T_{CAC}^{(1)}$	CLK to Data Delay		75		80		55		60	ns
$T_{OH}$	Data Hold from $\overline{CE}$ , OE, or CLK	0		0		0		0		ns
$T_{DF}^{(2)}$	$\overline{CE}$ or OE to Data Float Delay		55		55		50		50	ns
$T_{LC}$	CLK Low Time	25		25		25		25		ns
$T_{HC}$	CLK High Time	25		25		25		25		ns
$T_{SCE}$	$\overline{CE}$ Setup Time to CLK (to guarantee proper counting)	35		60		30		35		ns
$T_{HCE}$	$\overline{CE}$ Hold Time from CLK (to guarantee proper counting)	0		0		0		0		ns
$T_{HOE}$	OE High Time (guarantees counter is reset)	25		25		25		25		ns
$F_{MAX}$	Maximum Clock Frequency		10		10		15		10	MHz

- Notes: 1. AC test lead = 50 pF.  
2. Float delays are measured with 5 pF AC loads. Transition is measured  $\pm 200$  mV from steady-state active levels.

## AC Characteristics when Cascading

$$V_{CC} = 3.3V \pm 10\%$$

Symbol	Description	AT17LV65/128/256				AT17LV512/010/002/040				Units
		Commercial		Industrial		Commercial		Industrial		
		Min	Max	Min	Max	Min	Max	Min	Max	
$T_{CDF}^{(2)}$	CLK to Data Float Delay		60		60		50		50	ns
$T_{OCK}^{(1)}$	CLK to $\overline{CEO}$ Delay		55		60		50		55	ns
$T_{OCE}^{(1)}$	$\overline{CE}$ to $\overline{CEO}$ Delay		55		60		35		40	ns
$T_{OOE}^{(1)}$	$\overline{RESET}/OE$ to $\overline{CEO}$ Delay		40		45		35		35	ns
$F_{MAX}$	Maximum Clock Frequency		8		8		12.5		10	MHz

- Notes: 1. AC test lead = 50 pF.  
2. Float delays are measured with 5 pF AC loads. Transition is measured  $\pm 200$  mV from steady-state active levels.

## AC Characteristics

$V_{CC} = 5V \pm 5\%$  Commercial;  $V_{CC} = 5V \pm 10\%$  Industrial

Symbol	Description	AT17LV65/128/256				AT17LV512/010/002/040				Units
		Commercial		Industrial		Commercial		Industrial		
		Min	Max	Min	Max	Min	Max	Min	Max	
$T_{OE}^{(1)}$	OE to Data Delay		30		35		30		35	ns
$T_{CE}^{(1)}$	$\overline{CE}$ to Data Delay		45		45		45		45	ns
$T_{CAC}^{(1)}$	CLK to Data Delay		50		55		50		50	ns
$T_{OH}$	Data Hold from $\overline{CE}$ , OE, or CLK	0		0		0		0		ns
$T_{DF}^{(2)}$	$\overline{CE}$ or OE to Data Float Delay		50		50		50		50	ns
$T_{LC}$	CLK Low Time	20		20		20		20		ns
$T_{HC}$	CLK High Time	20		20		20		20		ns
$T_{SCE}$	$\overline{CE}$ Setup Time to CLK (to guarantee proper counting)	35		40		20		25		ns
$T_{HCE}$	$\overline{CE}$ Hold Time from CLK (to guarantee proper counting)	0		0		0		0		ns
$T_{HOE}$	OE High Time (guarantees counter is reset)	20		20		20		20		ns
$F_{MAX}$	Maximum Clock Frequency		12.5		12.5		15		15	MHz

- Notes: 1. AC test lead = 50 pF.  
 2. Float delays are measured with 5 pF AC loads. Transition is measured  $\pm 200$  mV from steady-state active levels.

## AC Characteristics when Cascading

$V_{CC} = 5V \pm 5\%$  Commercial;  $V_{CC} = 5V \pm 10\%$  Industrial

Symbol	Description	AT17LV65/128/256				AT17LV512/010/002/040				Units
		Commercial		Industrial		Commercial		Industrial		
		Min	Max	Min	Max	Min	Max	Min	Max	
$T_{CDF}^{(2)}$	CLK to Data Float Delay		50		50		50		50	ns
$T_{OCK}^{(1)}$	CLK to $\overline{CEO}$ Delay		35		40		35		40	ns
$T_{OCE}^{(1)}$	$\overline{CE}$ to $\overline{CEO}$ Delay		35		35		35		35	ns
$T_{OOE}^{(1)}$	$\overline{RESET/OE}$ to $\overline{CEO}$ Delay		30		35		30		30	ns
$F_{MAX}$	Maximum Clock Frequency		10		10		12.5		12.5	MHz

- Notes: 1. AC test lead = 50 pF.  
 2. Float delays are measured with 5 pF AC loads. Transition is measured  $\pm 200$  mV from steady-state active levels.

## Thermal Resistance Coefficients<sup>(1)</sup>

Package Type			AT17LV65/ AT17LV128/ AT17LV256	AT17LV512/ AT17LV010	AT17LV002	AT17LV040
8CN4	Leadless Array Package (LAP)	$\theta_{JC}$ [°C/W]	45	45	45	–
		$\theta_{JA}$ [°C/W] <sup>(2)</sup>	115.71	135.71	159.60	–
8P3	Plastic Dual Inline Package (PDIP)	$\theta_{JC}$ [°C/W]	37	37	–	–
		$\theta_{JA}$ [°C/W] <sup>(2)</sup>	107	107	–	–
8S1	Plastic Gull Wing Small Outline (SOIC)	$\theta_{JC}$ [°C/W]	45	–	–	–
		$\theta_{JA}$ [°C/W] <sup>(2)</sup>	150	–	–	–
20J	Plastic Leaded Chip Carrier (PLCC)	$\theta_{JC}$ [°C/W]	35	35	35	–
		$\theta_{JA}$ [°C/W] <sup>(2)</sup>	90	90	90	–
20S2	Plastic Gull Wing Small Outline (SOIC)	$\theta_{JC}$ [°C/W]				–
		$\theta_{JA}$ [°C/W] <sup>(2)</sup>				–
44A	Thin Plastic Quad Flat Package (TQFP)	$\theta_{JC}$ [°C/W]	–	–	17	17
		$\theta_{JA}$ [°C/W] <sup>(2)</sup>	–	–	62	62
44J	Plastic Leaded Chip Carrier (PLCC)	$\theta_{JC}$ [°C/W]	–	–	15	15
		$\theta_{JA}$ [°C/W] <sup>(2)</sup>	–	–	50	50

- Notes: 1. For more information refer to the “Thermal Characteristics of Atmel’s Packages”, available on the Atmel web site.  
2. Airflow = 0 ft/min.

Figure 1. Ordering Code

AT17LV65A-10PC

Voltage	Size (Bits)	Special Pinouts	Package	Temperature
3.0V to 5.5V	65 = 65K	A = Altera	C = 8CN4	C = Commercial
	128 = 128K	Blank = Xilinx/Atmel/ Other	P = 8P3	I = Industrial
	256 = 256K		N = 8S1	
	512 = 512K		J = 20J	
	010 = 1M		S = 20S2	
	002 = 2M		TQ = 44A	
	040 = 4M		BJ = 44J	

Package Type	
<b>8CN4</b>	8-lead, 6 mm x 6 mm x 1 mm, Leadless Array Package (LAP) – Pin-compatible with 8-lead SOIC/VOID Packages
<b>8P3</b>	8-lead, 0.300" Wide, Plastic Dual Inline Package (PDIP)
<b>8S1</b>	8-lead, 0.150" Wide, Plastic Gull Wing Small Outline (JEDEC SOIC)
<b>20J</b>	20-lead, Plastic J-leaded Chip Carrier (PLCC)
<b>20S2</b>	20-lead, 0.300" Wide, Plastic Gull Wing Small Outline (JEDEC SOIC)
<b>44A</b>	44-lead, Thin (1.0 mm) Plastic Quad Flat Package Carrier (TQFP)
<b>44J</b>	44-lead, Plastic J-leaded Chip Carrier (PLCC)

## Ordering Information

Memory Size	Ordering Code	Package	Operation Range
64-Kbit <sup>(1)</sup>	AT17LV65-10CC AT17LV65-10PC AT17LV65-10NC AT17LV65-10JC AT17LV65-10SC	8CN4 8P3 8S1 20J 20S2	Commercial (0°C to 70°C)
	AT17LV65-10CI AT17LV65-10PI AT17LV65-10NI AT17LV65-10JI AT17LV65-10SI	8CN4 8P3 8S1 20J 20S2	Industrial (-40°C to 85°C)
128-Kbit <sup>(1)</sup>	AT17LV128-10CC AT17LV128-10PC AT17LV128-10NC AT17LV128-10JC AT17LV128-10SC	8CN4 8P3 8S1 20J 20S2	Commercial (0°C to 70°C)
	AT17LV128-10CI AT17LV128-10PI AT17LV128-10NI AT17LV128-10JI AT17LV128-10SI	8CN4 8P3 8S1 20J 20S2	Industrial (-40°C to 85°C)
256-Kbit <sup>(1)</sup>	AT17LV256-10CC AT17LV256-10PC AT17LV256-10NC AT17LV256-10JC AT17LV256-10SC	8CN4 8P3 8S1 20J 20S2	Commercial (0°C to 70°C)
	AT17LV256-10CI AT17LV256-10PI AT17LV256-10NI AT17LV256-10JI AT17LV256-10SI	8CN4 8P3 8S1 20J 20S2	Industrial (-40°C to 85°C)
512-Kbit <sup>(1)</sup>	AT17LV512-10CC AT17LV512-10PC AT17LV512-10JC AT17LV512-10SC	8CN4 8P3 20J 20S2	Commercial (0°C to 70°C)
	AT17LV512-10CI AT17LV512-10PI AT17LV512-10JI AT17LV512-10SI	8CN4 8P3 20J 20S2	Industrial (-40°C to 85°C)
1-Mbit <sup>(1)</sup>	AT17LV010-10CC AT17LV010-10PC AT17LV010-10JC AT17LV010-10SC	8CN4 8P3 20J 20S2	Commercial (0°C to 70°C)
	AT17LV010-10CI AT17LV010-10PI AT17LV010-10JI AT17LV010-10SI	8CN4 8P3 20J 20S2	Industrial (-40°C to 85°C)
2-Mbit <sup>(1)</sup>	AT17LV002-10CC AT17LV002-10JC AT17LV002-10SC AT17LV002-10TQC AT17LV002-10BJC	8CN4 20J 20S2 44A 44J	Commercial (0°C to 70°C)
	AT17LV002-10CI AT17LV002-10JI AT17LV002-10SI AT17LV002-10TQI AT17LV002-10BJI	8CN4 20J 20S2 44A 44J	Industrial (-40°C to 85°C)
4-Mbit <sup>(1)</sup>	AT17LV040-10TQC AT17LV040-10BJC	44A 44J	Commercial (0°C to 70°C)
	AT17LV040-10TQI AT17LV040-10BJI	44A 44J	Industrial (-40°C to 85°C)

Note: 1. For operating voltage of 5V ±10%, please refer to the 5V ±10% AC and DC Characteristics.

Packaging Information

8CN4 – LAP

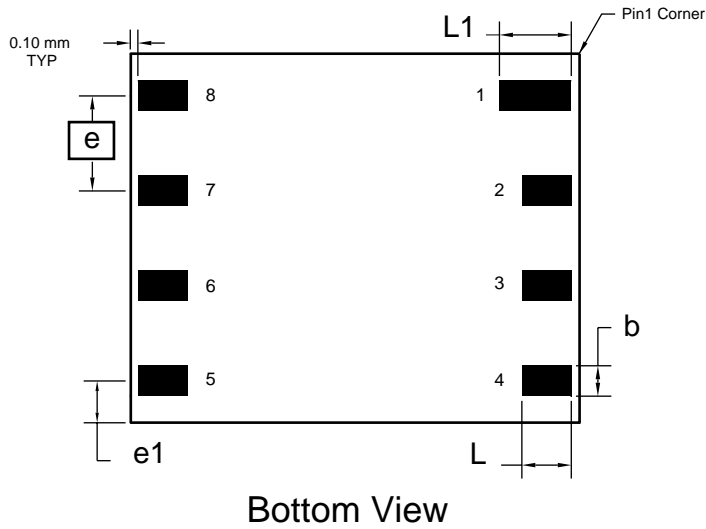
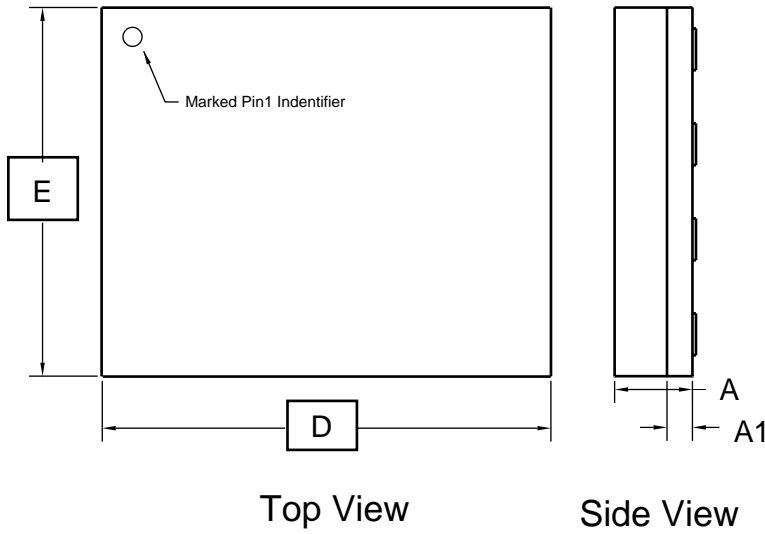

COMMON DIMENSIONS  
(Unit of Measure = mm)

SYMBOL	MIN	NOM	MAX	NOTE
A	0.94	1.04	1.14	
A1	0.30	0.34	0.38	
b	0.45	0.50	0.55	1
D	5.89	5.99	6.09	
E	4.89	5.99	6.09	
e	1.27 BSC			
e1	1.10 REF			
L	0.95	1.00	1.05	1
L1	1.25	1.30	1.35	1

Note: 1. Metal Pad Dimensions.

11/14/01



2325 Orchard Parkway  
San Jose, CA 95131

**TITLE**  
8CN4, 8-lead (6 x 6 x 1.04 mm Body), Lead Pitch 1.27 mm,  
Leadless Array Package (LAP)

**DRAWING NO.**  
8CN4

**REV.**  
A



### 8P3 – PDIP

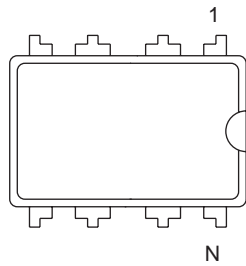

Top View

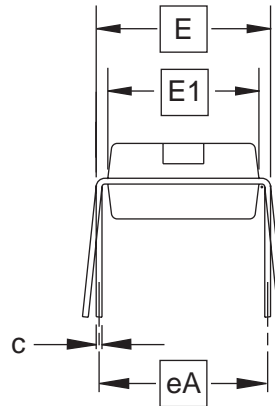

End View

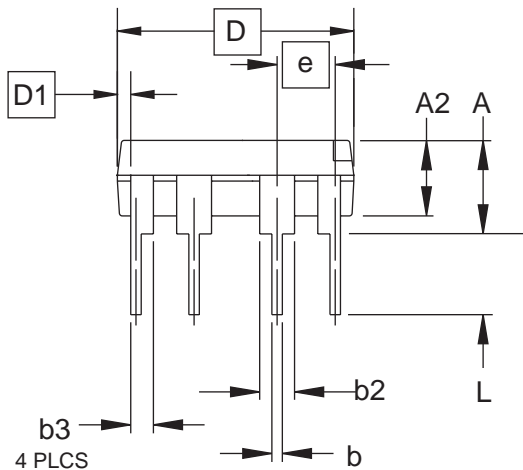

Side View

**COMMON DIMENSIONS**  
(Unit of Measure = inches)

SYMBOL	MIN	NOM	MAX	NOTE
A			0.210	2
A2	0.115	0.130	0.195	
b	0.014	0.018	0.022	5
b2	0.045	0.060	0.070	6
b3	0.030	0.039	0.045	6
c	0.008	0.010	0.014	
D	0.355	0.365	0.400	3
D1	0.005			3
E	0.300	0.310	0.325	4
E1	0.240	0.250	0.280	3
e	0.100 BSC			
eA	0.300 BSC			4
L	0.115	0.130	0.150	2

- Notes:
1. This drawing is for general information only; refer to JEDEC Drawing MS-001, Variation BA for additional information.
  2. Dimensions A and L are measured with the package seated in JEDEC seating plane Gauge GS-3.
  3. D, D1 and E1 dimensions do not include mold Flash or protrusions. Mold Flash or protrusions shall not exceed 0.010 inch.
  4. E and eA measured with the leads constrained to be perpendicular to datum.
  5. Pointed or rounded lead tips are preferred to ease insertion.
  6. b2 and b3 maximum dimensions do not include Dambar protrusions. Dambar protrusions shall not exceed 0.010 (0.25 mm).

01/09/02



2325 Orchard Parkway  
San Jose, CA 95131

**TITLE**

**8P3**, 8-lead, 0.300" Wide Body, Plastic Dual  
In-line Package (PDIP)

**DRAWING NO.**

8P3

**REV.**

B

8S1 – SOIC

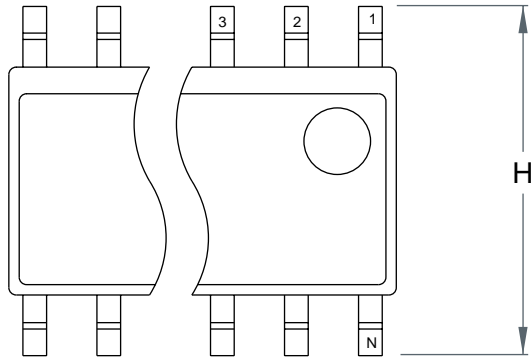

Top View

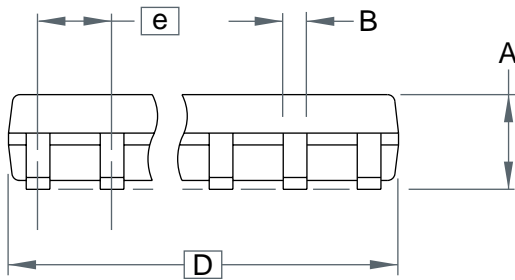

Side View

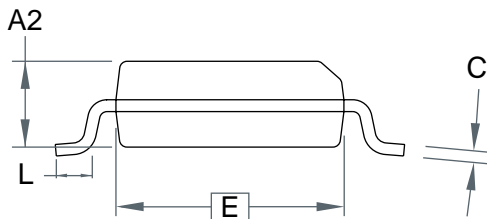

End View

**COMMON DIMENSIONS**  
(Unit of Measure = mm)

SYMBOL	MIN	NOM	MAX	NOTE
A	–	–	1.75	
B	–	–	0.51	
C	–	–	0.25	
D	–	–	5.00	
E	–	–	4.00	
e	1.27 BSC			
H	–	–	6.20	
L	–	–	1.27	

Note: This drawing is for general information only. Refer to JEDEC Drawing MS-012 for proper dimensions, tolerances, datums, etc.

10/10/01



2325 Orchard Parkway  
San Jose, CA 95131

**TITLE**  
8S1, 8-lead (0.150" Wide Body), Plastic Gull Wing  
Small Outline (JEDEC SOIC)

**DRAWING NO.**  
8S1

**REV.**  
A



# 20J – PLCC

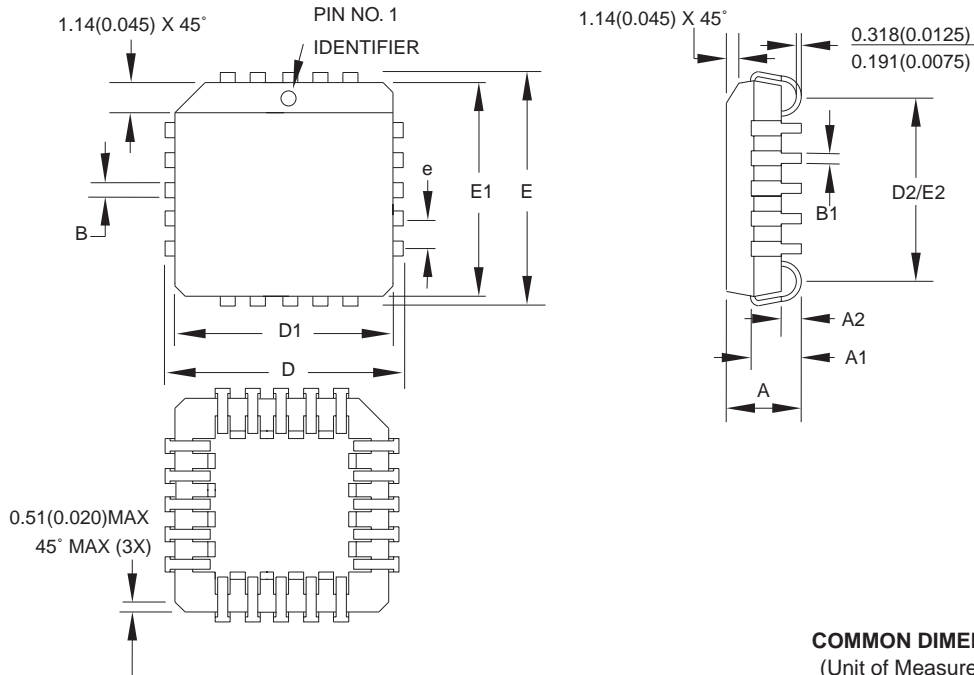

**COMMON DIMENSIONS**  
(Unit of Measure = mm)

SYMBOL	MIN	NOM	MAX	NOTE
A	4.191	–	4.572	
A1	2.286	–	3.048	
A2	0.508	–	–	
D	9.779	–	10.033	
D1	8.890	–	9.042	Note 2
E	9.779	–	10.033	
E1	8.890	–	9.042	Note 2
D2/E2	7.366	–	8.382	
B	0.660	–	0.813	
B1	0.330	–	0.533	
e	1.270 TYP			

- Notes:
1. This package conforms to JEDEC reference MS-018, Variation AA.
  2. Dimensions D1 and E1 do not include mold protrusion. Allowable protrusion is .010"(0.254 mm) per side. Dimension D1 and E1 include mold mismatch and are measured at the extreme material condition at the upper or lower parting line.
  3. Lead coplanarity is 0.004" (0.102 mm) maximum.

10/04/01



2325 Orchard Parkway  
San Jose, CA 95131

**TITLE**

**20J, 20-lead, Plastic J-leaded Chip Carrier (PLCC)**

**DRAWING NO.**

20J

**REV.**

B

20S2 – SOIC

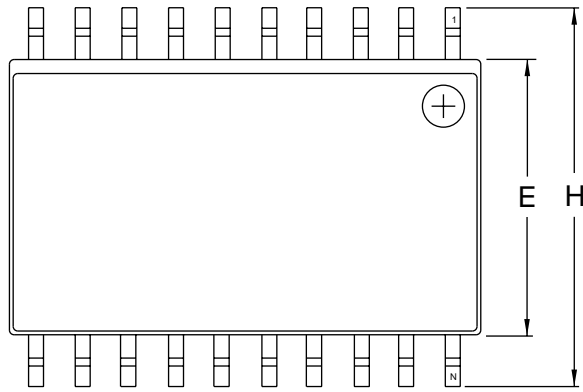

Top View

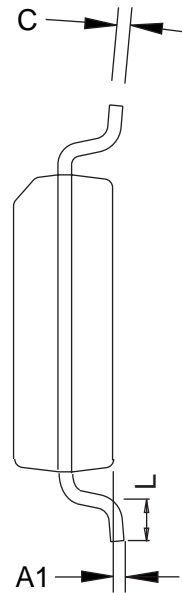

End View

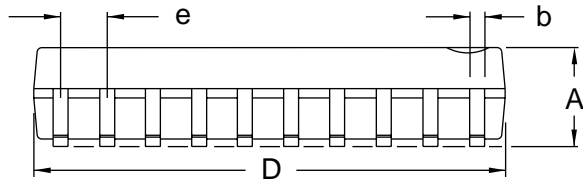

Side View

COMMON DIMENSIONS  
(Unit of Measure = inches)

SYMBOL	MIN	NOM	MAX	NOTE
A	0.0926		0.1043	
A1	0.0040		0.0118	
b	0.0130		0.0200	4
C	0.0091		0.0125	
D	0.4961		0.5118	1
E	0.2914		0.2992	2
H	0.3940		0.4190	
L	0.0160		0.050	3
e	0.050 BSC			

- Notes:
1. This drawing is for general information only; refer to JEDEC Drawing MS-013, Variation AC for additional information.
  2. Dimension "D" does not include mold Flash, protrusions or gate burrs. Mold Flash, protrusions and gate burrs shall not exceed 0.15 mm (0.006") per side.
  3. Dimension "E" does not include inter-lead Flash or protrusion. Inter-lead Flash and protrusions shall not exceed 0.25 mm (0.010") per side.
  4. "L" is the length of the terminal for soldering to a substrate.
  5. The lead width "b", as measured 0.36 mm (0.014") or greater above the seating plane, shall not exceed a maximum value of 0.61 mm (0.024") per side.



2325 Orchard Parkway  
San Jose, CA 95131

TITLE

20S2, 20-lead, 0.300" Wide Body, Plastic Gull  
Wing Small Outline Package (SOIC)

DRAWING NO.

20S2

REV.

A



# 44A – TQFP

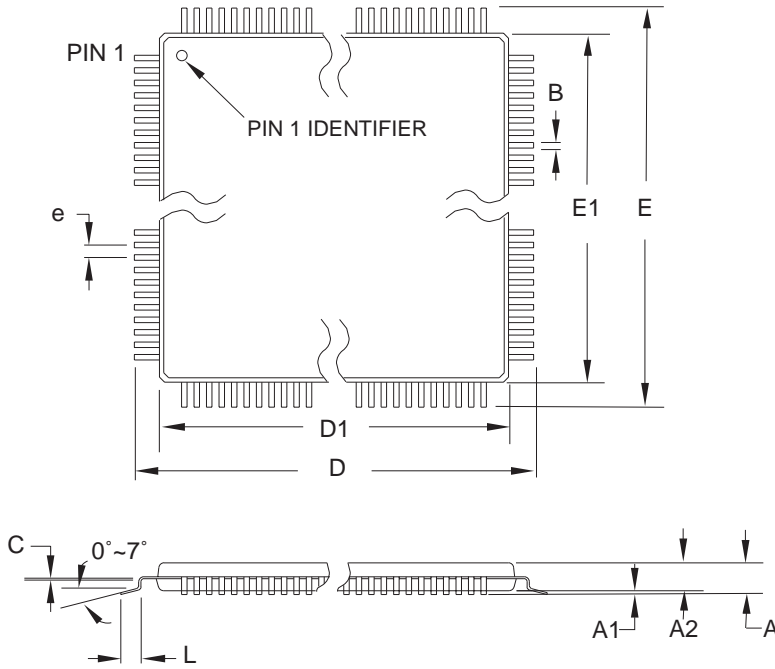

**COMMON DIMENSIONS**  
(Unit of Measure = mm)

SYMBOL	MIN	NOM	MAX	NOTE
A	–	–	1.20	
A1	0.05	–	0.15	
A2	0.95	1.00	1.05	
D	11.75	12.00	12.25	
D1	9.90	10.00	10.10	Note 2
E	11.75	12.00	12.25	
E1	9.90	10.00	10.10	Note 2
B	0.30	–	0.45	
C	0.09	–	0.20	
L	0.45	–	0.75	
e	0.80 TYP			

- Notes:
1. This package conforms to JEDEC reference MS-026, Variation ACB.
  2. Dimensions D1 and E1 do not include mold protrusion. Allowable protrusion is 0.25 mm per side. Dimensions D1 and E1 are maximum plastic body size dimensions including mold mismatch.
  3. Lead coplanarity is 0.10 mm maximum.

10/5/2001

2325 Orchard Parkway San Jose, CA 95131	<b>TITLE</b>	<b>DRAWING NO.</b>	<b>REV.</b>
	<b>44A</b> , 44-lead, 10 x 10 mm Body Size, 1.0 mm Body Thickness, 0.8 mm Lead Pitch, Thin Profile Plastic Quad Flat Package (TQFP)	44A	B

44J – PLCC

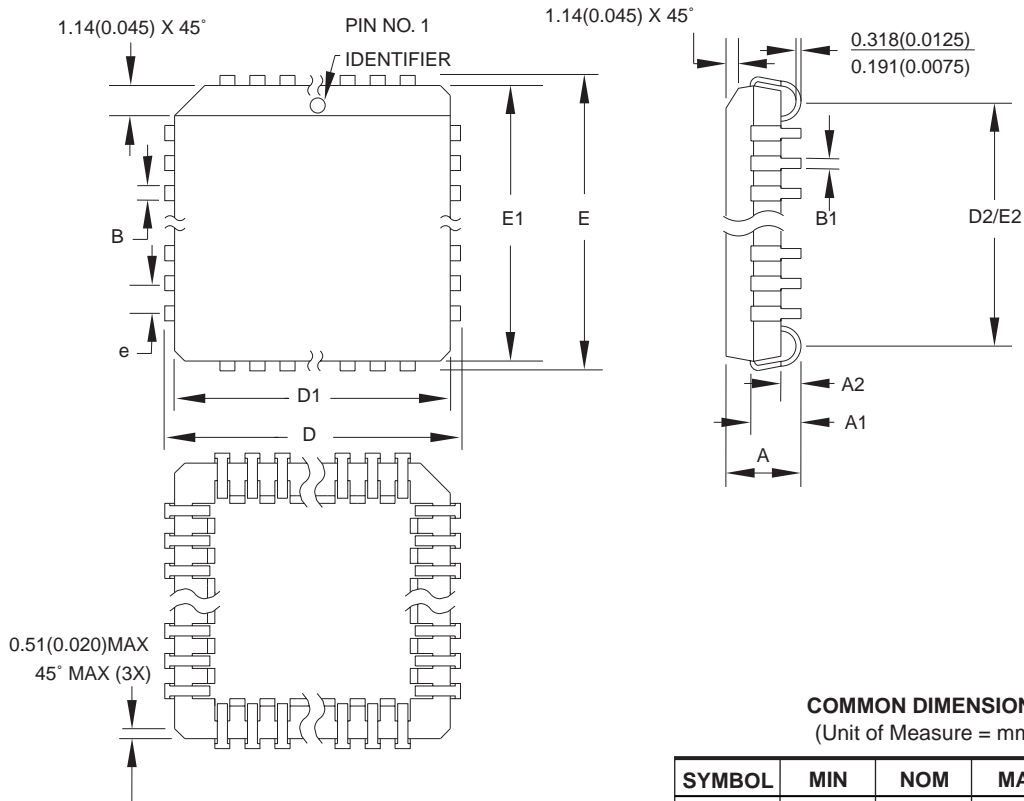

**COMMON DIMENSIONS**  
(Unit of Measure = mm)

SYMBOL	MIN	NOM	MAX	NOTE
A	4.191	–	4.572	
A1	2.286	–	3.048	
A2	0.508	–	–	
D	17.399	–	17.653	
D1	16.510	–	16.662	Note 2
E	17.399	–	17.653	
E1	16.510	–	16.662	Note 2
D2/E2	14.986	–	16.002	
B	0.660	–	0.813	
B1	0.330	–	0.533	
e	1.270 TYP			

- Notes:
1. This package conforms to JEDEC reference MS-018, Variation AC.
  2. Dimensions D1 and E1 do not include mold protrusion. Allowable protrusion is .010"(0.254 mm) per side. Dimension D1 and E1 include mold mismatch and are measured at the extreme material condition at the upper or lower parting line.
  3. Lead coplanarity is 0.004" (0.102 mm) maximum.

10/04/01



2325 Orchard Parkway  
San Jose, CA 95131

**TITLE**

**44J, 44-lead, Plastic J-leaded Chip Carrier (PLCC)**

**DRAWING NO.**

44J

**REV.**

B





## Atmel Headquarters

### *Corporate Headquarters*

2325 Orchard Parkway  
San Jose, CA 95131  
TEL 1(408) 441-0311  
FAX 1(408) 487-2600

### *Europe*

Atmel Sarl  
Route des Arsenaux 41  
Case Postale 80  
CH-1705 Fribourg  
Switzerland  
TEL (41) 26-426-5555  
FAX (41) 26-426-5500

### *Asia*

Room 1219  
Chinachem Golden Plaza  
77 Mody Road Tsimhatsui  
East Kowloon  
Hong Kong  
TEL (852) 2721-9778  
FAX (852) 2722-1369

### *Japan*

9F, Tonetsu Shinkawa Bldg.  
1-24-8 Shinkawa  
Chuo-ku, Tokyo 104-0033  
Japan  
TEL (81) 3-3523-3551  
FAX (81) 3-3523-7581

## Atmel Operations

### *Memory*

2325 Orchard Parkway  
San Jose, CA 95131  
TEL 1(408) 441-0311  
FAX 1(408) 436-4314

### *Microcontrollers*

2325 Orchard Parkway  
San Jose, CA 95131  
TEL 1(408) 441-0311  
FAX 1(408) 436-4314

La Chantrerie  
BP 70602  
44306 Nantes Cedex 3, France  
TEL (33) 2-40-18-18-18  
FAX (33) 2-40-18-19-60

### *ASIC/ASSP/Smart Cards*

Zone Industrielle  
13106 Rousset Cedex, France  
TEL (33) 4-42-53-60-00  
FAX (33) 4-42-53-60-01

1150 East Cheyenne Mtn. Blvd.  
Colorado Springs, CO 80906  
TEL 1(719) 576-3300  
FAX 1(719) 540-1759

Scottish Enterprise Technology Park  
Maxwell Building  
East Kilbride G75 0QR, Scotland  
TEL (44) 1355-803-000  
FAX (44) 1355-242-743

### *RF/Automotive*

Theresienstrasse 2  
Postfach 3535  
74025 Heilbronn, Germany  
TEL (49) 71-31-67-0  
FAX (49) 71-31-67-2340

1150 East Cheyenne Mtn. Blvd.  
Colorado Springs, CO 80906  
TEL 1(719) 576-3300  
FAX 1(719) 540-1759

### *Biometrics/Imaging/Hi-Rel MPU/ High Speed Converters/RF Datacom*

Avenue de Rochepleine  
BP 123  
38521 Saint-Egreve Cedex, France  
TEL (33) 4-76-58-30-00  
FAX (33) 4-76-58-34-80

---

*Atmel Programmable SLI Hotline*  
(408) 436-4119

*Atmel Programmable SLI e-mail*  
configurator@atmel.com

*FAQ*  
Available on web site

*e-mail*  
literature@atmel.com

*Web Site*  
<http://www.atmel.com>

## © Atmel Corporation 2002.

Atmel Corporation makes no warranty for the use of its products, other than those expressly contained in the Company's standard warranty which is detailed in Atmel's Terms and Conditions located on the Company's web site. The Company assumes no responsibility for any errors which may appear in this document, reserves the right to change devices or specifications detailed herein at any time without notice, and does not make any commitment to update the information contained herein. No licenses to patents or other intellectual property of Atmel are granted by the Company in connection with the sale of Atmel products, expressly or by implication. Atmel's products are not authorized for use as critical components in life support devices or systems.

Atmel® is the registered trademark of Atmel.

FLEX™ is the trademark of Altera Corporation; ORCA™ is the trademark of Lattice Semiconductors; SPARTAN® and Virtex® are the registered trademarks of Xilinx, Inc.; XC3000™, XC4000™ and XC5200™ are the trademarks of Xilinx, Inc.; APEX™ is the trademark of MIPS Technologies; Other terms and product names may be the trademarks of others.



Printed on recycled paper.