

## Features

- Incorporates the ARM7TDMI<sup>®</sup> ARM<sup>®</sup> Thumb<sup>®</sup> Processor
  - High-performance 32-bit RISC Architecture
  - High-density 16-bit Instruction Set
  - Leader in MIPS/Watt
- Embedded ICE In-circuit Emulation, Debug Communication Channel Support
- 256 Kbytes of Internal High-speed Flash, Organized in 1024 Pages of 256 Bytes
  - Single Cycle Access at Up to 30 MHz in Worst Case Conditions
  - Prefetch Buffer Optimizing Thumb Instruction Execution at Maximum Speed
  - Page Programming Time: 6 ms, Including Page Auto-erase, Full Erase Time: 15 ms
  - 10,000 Write Cycles, 10-year Data Retention Capability, Sector Lock Capabilities
- 32K Bytes of Internal High-speed SRAM, Single-cycle Access at Maximum Speed
- Memory Controller (MC)
  - Embedded Flash Controller, Abort Status and Misalignment Detection
  - Memory Protection Unit
- Reset Controller (RSTC)
  - Based on Three Power-on Reset Cells
  - Provides External Reset Signal Shaping and Reset Sources Status
- Clock Generator (CKGR)
  - Low-power RC Oscillator, 3 to 20 MHz On-chip Oscillator and One PLL
- Power Management Controller (PMC)
  - Power Optimization Capabilities, including Slow Clock Mode (Down to 500 Hz), Idle Mode, Standby Mode and Backup Mode
  - Four Programmable External Clock Signals
- Advanced Interrupt Controller (AIC)
  - Individually Maskable, Eight-level Priority, Vectored Interrupt Sources
  - Four External Interrupt Sources and One Fast Interrupt Source, Spurious Interrupt Protected
- Debug Unit (DBGU)
  - 2-wire UART and Support for Debug Communication Channel interrupt
- Periodic Interval Timer (PIT)
  - 20-bit Programmable Counter plus 12-bit Interval Counter
- Windowed Watchdog (WDT)
  - 12-bit key-protected Programmable Counter
  - Provides Reset or Interrupt Signal to the System
  - Counter May Be Stopped While the Processor is in Debug Mode or in Idle State
- Real-time Timer (RTT)
  - 32-bit Free-running Counter with Alarm
  - Runs Off the Internal RC Oscillator
- Two Parallel Input/Output Controllers (PIO)
  - Sixty-two Programmable I/O Lines Multiplexed with up to Two Peripheral I/Os
  - Input Change Interrupt Capability on Each I/O Line
  - Individually Programmable Open-drain, Pull-up resistor and Synchronous Output
- Shutdown Controller (SHDWC)
  - Programmable Shutdown Pin and Wake-up Circuitry
- Two 32-bit Battery Backup Registers for a Total of 8 Bytes
- One 8-channel 20-bit PWM Controller (PWMC)
- One USB 2.0 Full Speed (12 Mbits per Second) Device Port
  - On-chip Transceiver, 2376-byte Configurable Integrated FIFOs



## AT91 ARM<sup>®</sup> Thumb<sup>®</sup>-based Microcontrollers

### AT91SAM7A3

## Summary

## Preliminary

6042BS-ATARM-30-Sep-05



Note: This is a summary document. A complete document is available on our Web site at [www.atmel.com](http://www.atmel.com).



- Nineteen Peripheral DMA Controller (PDC) Channels
- Two CAN 2.0B Active Controllers, Supporting 11-bit Standard and 29-bit Extended Identifiers
  - 16 Fully Programmable Message Object Mailboxes, 16-bit Time Stamp Counter
- Two 8-channel 10-bit Analog-to-Digital Converter
- Three Universal Synchronous/Asynchronous Receiver Transmitters (USART)
  - Individual Baud Rate Generator, IrDA Infrared Modulation/Demodulation
  - Support for ISO7816 T0/T1 Smart Card, Hardware Handshaking, RS485 Support
- Two Master/Slave Serial Peripheral Interfaces (SPI)
  - 8- to 16-bit Programmable Data Length, Four External Peripheral Chip Selects
- Three 3-channel 16-bit Timer/Counters (TC)
  - Three External Clock Inputs, Two Multi-purpose I/O Pins per Channel
  - Double PWM Generation, Capture/Waveform Mode, Up/Down Capability
- Two Synchronous Serial Controllers (SSC)
  - Independent Clock and Frame Sync Signals for Each Receiver and Transmitter
  - I<sup>2</sup>S Analog Interface Support, Time Division Multiplex Support
  - High-speed Continuous Data Stream Capabilities with 32-bit Data Transfer
- One Two-wire Interface (TWI)
  - Master Mode Support Only, All Two-wire Atmel EEPROM's Supported
- Multimedia Card Interface (MCI)
  - Compliant with Multimedia Cards and SD Cards
  - Automatic Protocol Control and Fast Automatic Data Transfers with PDC, MMC and SDCard Compliant
- IEEE 1149.1 JTAG Boundary Scan on All Digital Pins
- Required Power Supplies
  - Embedded 1.8V Regulator, Drawing up to 130 mA for the Core and the External Components, Enables 3.3V Single Supply Mode
  - 3.3V VDD3V3 Regulator, I/O Lines and Flash Power Supply
  - 1.8V VDD1V8 Output of the Voltage Regulator and Core Power Supply
  - 3V to 3.6V VDDANA ADC Power Supply
  - 3V to 3.6V VDDBU Backup Power Supply
- 5V-tolerant I/Os
- Fully Static Operation: Up to 60 MHz at 1.65V and 85°C Worst Case Conditions
- Available in a 100-lead LQFP Green Package

## 1. Description

The AT91SAM7A3 is a member of a series of 32-bit ARM7<sup>®</sup> microcontrollers with an integrated CAN controller. It features a 256-Kbyte high-speed Flash and 32-Kbyte SRAM, a large set of peripherals, including two 2.0B full CAN controllers, and a complete set of system functions minimizing the number of external components. The device is an ideal migration path for 8-bit microcontroller users looking for additional performance and extended memory.

The embedded Flash memory can be programmed in-system via the JTAG-ICE interface. Built-in lock bits protect the firmware from accidental overwrite.

The AT91SAM7A3 integrates a complete set of features facilitating debug, including a JTAG In-Circuit-Emulation interface, misalignment detector, interrupt driven debug communication channel for user configurable trace on a console, and JTAG boundary scan for board level debug and test.

By combining a high-performance 32-bit RISC processor with a high-density 16-bit instruction set, Flash and SRAM memory, a wide range of peripherals including CAN controllers, 10-bit ADC, Timers and serial communication channels, on a monolithic chip, the AT91SAM7A3 is ideal for many compute-intensive embedded control applications in the automotive, medical and industrial world.

## 2. Block Diagram

Figure 2-1. AT91SAM7A3 Block Diagram

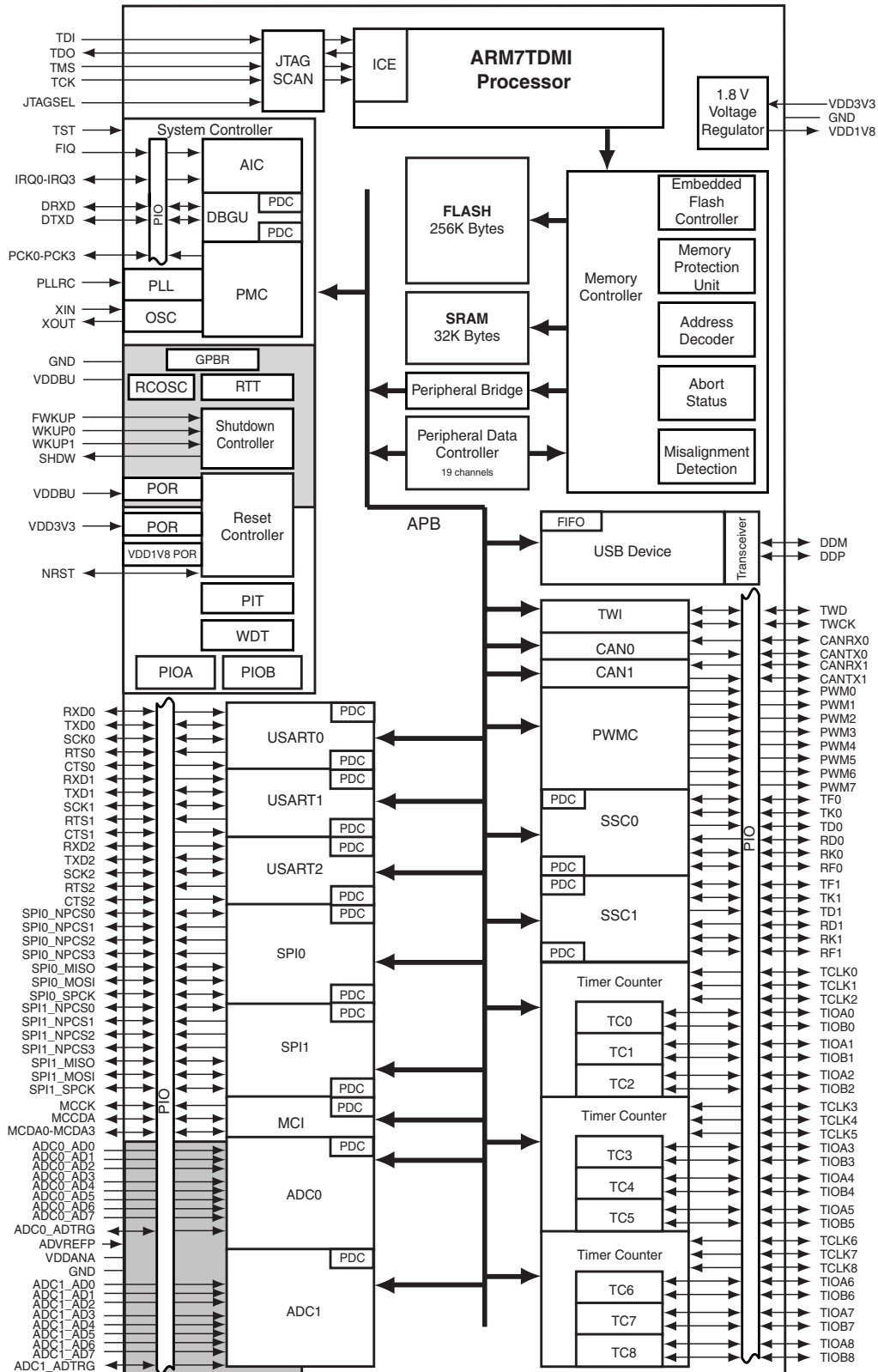

## 3. Signal Description

**Table 3-1.** Signal Description

Signal Name	Function	Type	Active Level	Comments
<b>Power</b>				
VDD3V3	1.8V Voltage Regulator, I/O Lines and Flash Power Supply	Power		3.0V to 3.6V
VDDDBU	Backup I/O Lines Power Supply	Power		3V to 3.6V
VDDANA	Analog Power Supply	Power		3V to 3.6V
VDD1V8	1.8V Voltage Regulator Output and Core Power Supply	Power		1.85V typical
VDDPLL	1.8V PLL Power Supply	Power		1.65V to 1.95V
GND	Ground	Ground		
<b>Clocks, Oscillators and PLLs</b>				
XIN	Main Oscillator Input	Input		
XOUT	Main Oscillator Output	Output		
PLLRC	PLL Filter	Input		
PCK0 - PCK3	Programmable Clock Output	Output		
SHDW	Shut-Down Control	Output		Driven at 0V only. Do not tie over VDDDBU
WKUP0 - WKUP1	Wake-Up Inputs	Input		Accept between 0V and VDDDBU
FWKUP	Force Wake Up	Input		Accept between 0V and VDDDBU
<b>ICE and JTAG</b>				
TCK	Test Clock	Input		No pull-up resistor
TDI	Test Data In	Input		No pull-up resistor
TDO	Test Data Out	Output		
TMS	Test Mode Select	Input		No pull-up resistor
JTAGSEL	JTAG Selection	Input		Pull-down resistor
<b>Reset/Test</b>				
NRST	Microcontroller Reset	I/O	Low	
TST	Test Mode Select	Input	High	Pull-down resistor
<b>Debug Unit</b>				
DRXD	Debug Receive Data	Input		
DTXD	Debug Transmit Data	Output		



**Table 3-1.** Signal Description (Continued)

Signal Name	Function	Type	Active Level	Comments
<b>AIC</b>				
IRQ0 - IRQ3	External Interrupt Inputs	Input		
FIQ	Fast Interrupt Input	Input		
<b>PIO</b>				
PA0 - PA31	Parallel IO Controller A	I/O		Pulled-up input at reset
PB0 - PB29	Parallel IO Controller B	I/O		Pulled-up input at reset
<b>Multimedia Card Interface</b>				
MCKK	Multimedia Card Clock	Output		
MCCDA	Multimedia Card A Command	I/O		
MCDA0 - MCDA3	Multimedia Card A Data	I/O		
<b>USB Device Port</b>				
DDM	USB Device Port Data -	Analog		
DDP	USB Device Port Data +	Analog		
<b>USART</b>				
SCK0 - SCK1 - SCK2	Serial Clock	I/O		
TXD0 - TXD1 - TXD2	Transmit Data	I/O		
RXD0 - RXD1 - RXD2	Receive Data	Input		
RTS0 - RTS1 - RTS2	Request To Send	Output		
CTS0 - CTS1 - CTS2	Clear To Send	Input		
<b>Synchronous Serial Controller</b>				
TD0 - TD1	Transmit Data	Output		
RD0 - RD1	Receive Data	Input		
TK0 - TK1	Transmit Clock	I/O		
RK0 - RK1	Receive Clock	I/O		
TF0 - TF1	Transmit Frame Sync	I/O		
RF0 - RF1	Receive Frame Sync	I/O		
<b>Timer/Counter</b>				
TCLK0 - TCLK8	External Clock Input	Input		
TIOA0 - TIOA8	I/O Line A	I/O		
TIOB0 - TIOB8	I/O Line B	I/O		
<b>PWM Controller</b>				
PWM0 - PWM7	PWM Channels	Output		

**Table 3-1.** Signal Description (Continued)

Signal Name	Function	Type	Active Level	Comments
<b>SPI</b>				
SPI0_MISO SPI1_MISO	Master In Slave Out	I/O		
SPI0_MOSI SPI1_MOSI	Master Out Slave In	I/O		
SPI0_SPCK SPI1_SPCK	SPI Serial Clock	I/O		
SPI0_NPCS0 SPI1_NPCS0	SPI Peripheral Chip Select 0	I/O	Low	
SPI0_NPCS1 - SPI0_NPCS3 SPI1_NPCS1 - SPI1_NPCS3	SPI Peripheral Chip Select	Output	Low	
<b>Two-wire Interface</b>				
TWD	Two-wire Serial Data	I/O		
TWCK	Two-wire Serial Clock	I/O		
<b>Analog-to-Digital Converter</b>				
ADC0_AD0 - ADC0_AD7 ADC1_AD0 - ADC1_AD7	Analog Inputs	Analog		Digital pulled-up inputs at reset
ADVREFP	Analog Positive Reference	Analog		
ADC0_ADTRG ADC1_ADTRG	ADC Trigger	Input		
<b>CAN Controller</b>				
CANRX0-CANRX1	CAN Inputs	Input		
CANTX0-CANTX1	CAN Outputs	Output		

## 4. Package and Pinout

### 4.1 100-lead LQFP Mechanical Overview

Figure 4-1 shows the orientation of the 100-lead LQFP package. A detailed mechanical description is given in the section Mechanical Characteristics of the full datasheet.

Figure 4-1. 100-lead LQFP Pinout (Top View)

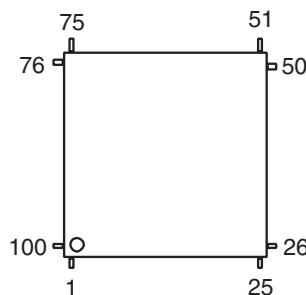

### 4.2 Pinout

Table 4-1. Pinout in 100-lead LQFP Package

1	GND	26	VDDBU	51	PA20	76	PLLRC
2	NRST	27	FWKUP	52	PA21	77	VDDANA
3	TST	28	WKUP0	53	PA22	78	ADVREFP
4	PB13	29	WKUP1	54	PA23	79	GND
5	PB12	30	SHDW	55	PA24	80	PB14/ADC0_AD0
6	PB11	31	GND	56	PA25	81	PB15/ADC0_AD1
7	PB10	32	PA4	57	PA26	82	PB16/ADC0_AD2
8	PB9	33	PA5	58	PA27	83	PB17/ADC0_AD3
9	PB8	34	PA6	59	VDD1V8	84	PB18/ADC0_AD4
10	PB7	35	PA7	60	GND	85	PB19/ADC0_AD5
11	PB6	36	PA8	61	VDD3V3	86	PB20/ADC0_AD6
12	PB5	37	PA9	62	PA28	87	PB21/ADC0_AD7
13	PB4	38	VDD3V3	63	PA29	88	VDD3V3
14	PB3	39	GND	64	PA30	89	PB22/ADC1_AD0
15	VDD3V3	40	VDD1V8	65	PA31	90	PB23/ADC1_AD1
16	GND	41	PA10	66	JTAGSEL	91	PB24/ADC1_AD2
17	VDD1V8	42	PA11	67	TDI	92	PB25/ADC1_AD3
18	PB2	43	PA12	68	TMS	93	PB26/ADC1_AD4
19	PB1	44	PA13	69	TCK	94	PB27/ADC1_AD5
20	PB0	45	PA14	70	TDO	95	PB28/ADC1_AD6
21	PA0	46	PA15	71	GND	96	PB29/ADC1_AD7
22	PA1	47	PA16	72	VDDPLL	97	DDM
23	PA2	48	PA17	73	XOUT	98	DDP
24	PA3	49	PA18	74	XIN	99	VDD1V8
25	GND	50	PA19	75	GND	100	VDD3V3

## 5. Power Considerations

### 5.1 Power Supplies

The AT91SAM7A3 has five types of power supply pins:

- VDD3V3 pins. They power the voltage regulator, the I/O lines, the Flash and the USB transceivers; voltage ranges from 3.0V to 3.6V, 3.3V nominal.
- VDD1V8 pins. They are the outputs of the 1.8V voltage regulator and they power the logic of the device.
- VDDPLL pin. It powers the PLL; voltage ranges from 1.65V to 1.95V, 1.8V typical. They can be connected to the VDD1V8 pin with decoupling capacitor.
- VDDBU pin. It powers the Slow Clock oscillator and the Real Time Clock, as well as a part of the System Controller; ranges from 3.0V and 3.6V, 3.3V nominal.
- VDDANA pin. It powers the ADC; ranges from 3.0V and 3.6V, 3.3V nominal.

No separate ground pins are provided for the different power supplies. Only GND pins are provided and should be connected as shortly as possible to the system ground plane.

### 5.2 Voltage Regulator

The AT91SAM7A3 embeds a voltage regulator that consumes less than 120  $\mu$ A static current and draws up to 130 mA of output current.

Adequate output supply decoupling is mandatory for VDD1V8 (pin 99) to reduce ripple and avoid oscillations. The best way to achieve this is to use two capacitors in parallel: one external 470 pF (or 1 nF) NPO capacitor must be connected between VDD1V8 and GND as close to the chip as possible. One external 3.3  $\mu$ F (or 4.7  $\mu$ F) X7R capacitor must be connected between VDD1V8 and GND.

All other VDD1V8 pins must be externally connected and have a proper decoupling capacitor (at least 100 nF).

Adequate input supply decoupling is mandatory for VDD3V3 (pin 100) in order to improve start-up stability and reduce source voltage drop. The input decoupling capacitor should be placed close to the chip. For example, two capacitors can be used in parallel: 100 nF NPO and 4.7  $\mu$ F X7R.

All other VDD3V3 pins must be externally connected and have a proper decoupling capacitor (at least 100 nF).

## 5.3 Typical Powering Schematics

### 5.3.1 3.3V Single Supply

The AT91SAM7A3 supports a 3.3V single supply mode. The internal regulator is connected to the 3.3V source and its output feeds VDDPLL. Figure 5-1 shows the power schematics to be used for USB bus-powered systems.

**Figure 5-1.** 3.3V System Single Power Supply Schematics

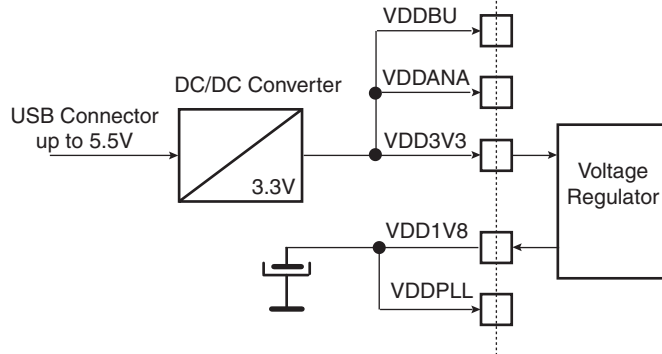

## 6. I/O Lines Considerations

### 6.1 JTAG Port Pins

TMS, TDI and TCK are schmitt trigger inputs. TMS and TCK are 5V-tolerant, TDI is not. TMS, TDI and TCK do not integrate any resistors and have to be pulled-up externally.

TDO is an output, driven at up to VDD3V3.

The JTAGSEL pin is used to select the JTAG boundary scan when asserted at a high level.

The JTAGSEL pin integrates a permanent pull-down resistor so that it can be left unconnected for normal operations.

### 6.2 Test Pin

The TST pin is used for manufacturing tests and integrates a pull-down resistor so that it can be left unconnected for normal operations. Driving this line at a high level leads to unpredictable results.

### 6.3 Reset Pin

The NRST pin is bidirectional. It is handled by the on-chip reset controller and can be driven low to provide a reset signal to the external components or asserted low externally to reset the microcontroller. There is no constraint on the length of the reset pulse, and the reset controller can guarantee a minimum pulse length. This allows connection of a simple push-button on the NRST pin as system user reset, and the use of the NRST signal to reset all the components of the system.

### 6.4 PIO Controller A and B Lines

All the I/O lines PA0 to PA31 and PB0 to PB29 are 5V-tolerant and all integrate a programmable pull-up resistor. Programming of this pull-up resistor is performed independently for each I/O line through the PIO Controllers.

5V-tolerant means that the I/O lines can drive voltage level according to VDD3V3, but can be driven with a voltage at up to 5.5V. However, driving an I/O line with a voltage over VDD3V3 while the programmable pull-up resistor is enabled creates a current path through the pull-up resistor from the I/O line to VDDIO. Care should be taken, especially at reset, as all the I/O lines default as inputs with pull-up resistor enabled at reset.

### 6.5 Shutdown Logic Pins

The SHDW pin is an open drain output. It can be tied to VDDBU with an external pull-up resistor.

The FWUP, WKUP0 and WKUP1 pins are input-only. They can accept voltages only between 0V and VDDBU. It is recommended to tie these pins either to GND or to VDDBU with an external resistor.

### 6.6 I/O Line Drive Levels

All the I/O lines can draw up to 2 mA.

## 7. Processor and Architecture

### 7.1 ARM7TDMI Processor

- RISC Processor Based on ARMv4T Von Neumann Architecture
  - Runs at up to 60 MHz, providing 0.9 MIPS/MHz
- Two instruction sets
  - ARM high-performance 32-bit Instruction Set
  - Thumb high code density 16-bit Instruction Set
- Three-stage pipeline architecture
  - Instruction Fetch (F)
  - Instruction Decode (D)
  - Execute (E)

### 7.2 Debug and Test Features

- Integrated embedded in-circuit emulator
  - Two watchpoint units
  - Test access port accessible through a JTAG protocol
  - Debug communication channel
- Debug Unit
  - Two-pin UART
  - Debug communication channel interrupt handling
  - Chip ID Register
- IEEE1149.1 JTAG Boundary-scan on all digital pins

### 7.3 Memory Controller

- Bus Arbiter
  - Handles requests from the ARM7TDMI and the Peripheral Data Controller
- Address Decoder Provides Selection Signals for
  - Three internal 1Mbyte memory areas
  - One 256 Mbyte embedded peripheral area
- Abort Status Registers
  - Source, Type and all parameters of the access leading to an abort are saved
  - Facilitates debug by detection of bad pointers
- Misalignment Detector
  - Alignment checking of all data accesses
  - Abort generation in case of misalignment
- Remap Command
  - Remaps the Internal SRAM in place of the embedded non-volatile memory
  - Allows handling of dynamic exception vectors
- 16-area Memory Protection Unit
  - Individually programmable size between 1K Bytes and 1M Bytes

- Individually programmable protection against write and/or user access
- Peripheral protection against write and/or user access
- Embedded Flash Controller
  - Embedded Flash interface, up to three programmable wait states
  - Read-optimized interface, buffering and anticipating the 16-bit requests, reducing the required wait states
  - Password-protected program, erase and lock/unlock sequencer
  - Automatic consecutive programming, erasing and locking operations
  - Interrupt generation in case of forbidden operation

## 7.4 Peripheral DMA Controller

- Handles data transfer between peripherals and memories
- Nineteen Channels
  - Two for each USART
  - Two for the Debug Unit
  - Two for each Serial Synchronous Controller
  - Two for each Serial Peripheral Interface
  - One for the Multimedia Card Interface
  - One for each Analog-to-Digital Converter
- Low bus arbitration overhead
  - One Master Clock cycle needed for a transfer from memory to peripheral
  - Two Master Clock cycles needed for a transfer from peripheral to memory
- Next Pointer management for reducing interrupt latency requirements

## 8. Memory

### 8.1 Embedded Memories

- 256 Kbytes of Flash Memory
  - 1024 pages of 256 bytes.
  - Fast access time, 30 MHz single cycle access in worst case conditions.
  - Page programming time: 6 ms, including page auto-erase
  - Full erase time: 15 ms
  - 10,000 write cycles, 10-year data retention capability
  - 16 lock bits, each protecting 16 pages
- 32 Kbytes of Fast SRAM
  - Single-cycle access at full speed

### 8.2 Memory Mapping

#### 8.2.1 Internal RAM

The AT91SAM7A3 embeds a high-speed 32-Kbyte SRAM bank. After reset and until the Remap Command is performed, the SRAM is only accessible at address 0x0020 0000. After Remap, the SRAM also becomes available at address 0x0.

#### 8.2.2 Internal Flash

The AT91SAM7A3 features one bank of 256 Kbytes of Flash. The Flash is mapped to address 0x0010 0000. It is also accessible at address 0x0 after the reset and before the Remap Command.

**Figure 8-1.** Internal Memory Mapping

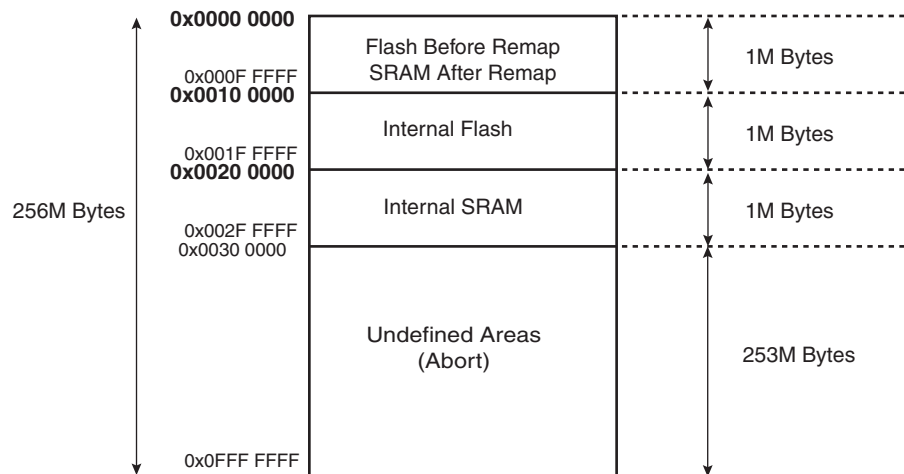

## 8.3 Embedded Flash

### 8.3.1 Flash Overview

The Flash block of the AT91SAM7A3 is organized in 1024 pages of 256 bytes. It reads as 65,536 32-bit words.

The Flash block contains a 256-byte write buffer, accessible through a 32-bit interface.

When Flash is not used (read or write access), it is automatically put into standby mode.

### 8.3.2 Embedded Flash Controller

The Embedded Flash Controller (EFC) manages accesses performed by the masters of the system. It enables reading the Flash and writing the write buffer. It also contains a User Interface mapped within the Memory Controller on the APB. The User Interface allows:

- programming of the access parameters of the Flash (number of wait states, timings, etc.)
- starting commands such as full erase, page erase, page program, NVM bit set, NVM bit clear, etc.
- getting the end status of the last command
- getting error status
- programming interrupts on the end of the last commands or on errors

The Embedded Flash Controller also provides a dual 32-bit Prefetch Buffer that optimizes 16-bit access to the Flash. This is particularly efficient when the processor is running in Thumb mode.

### 8.3.3 Lock Regions

The Embedded Flash Controller manages 16 lock bits to protect 16 regions of the Flash against inadvertent Flash erasing or programming commands.

The AT91SAM7A3 has 16 lock regions. Each lock region contains 16 pages of 256 bytes. Each lock region has a size of 4 Kbytes, thus only the first 64 Kbytes can be locked.

The 16 NVM bits are software programmable through the EFC User Interface. The command “Set Lock Bit” activates the protection. The command “Clear Lock Bit” unlocks the lock region.

## 9. System Controller

The System Controller manages all vital blocks of the microcontroller: interrupts, clocks, power, time, debug and reset.

**Figure 9-1.** System Controller Block Diagram

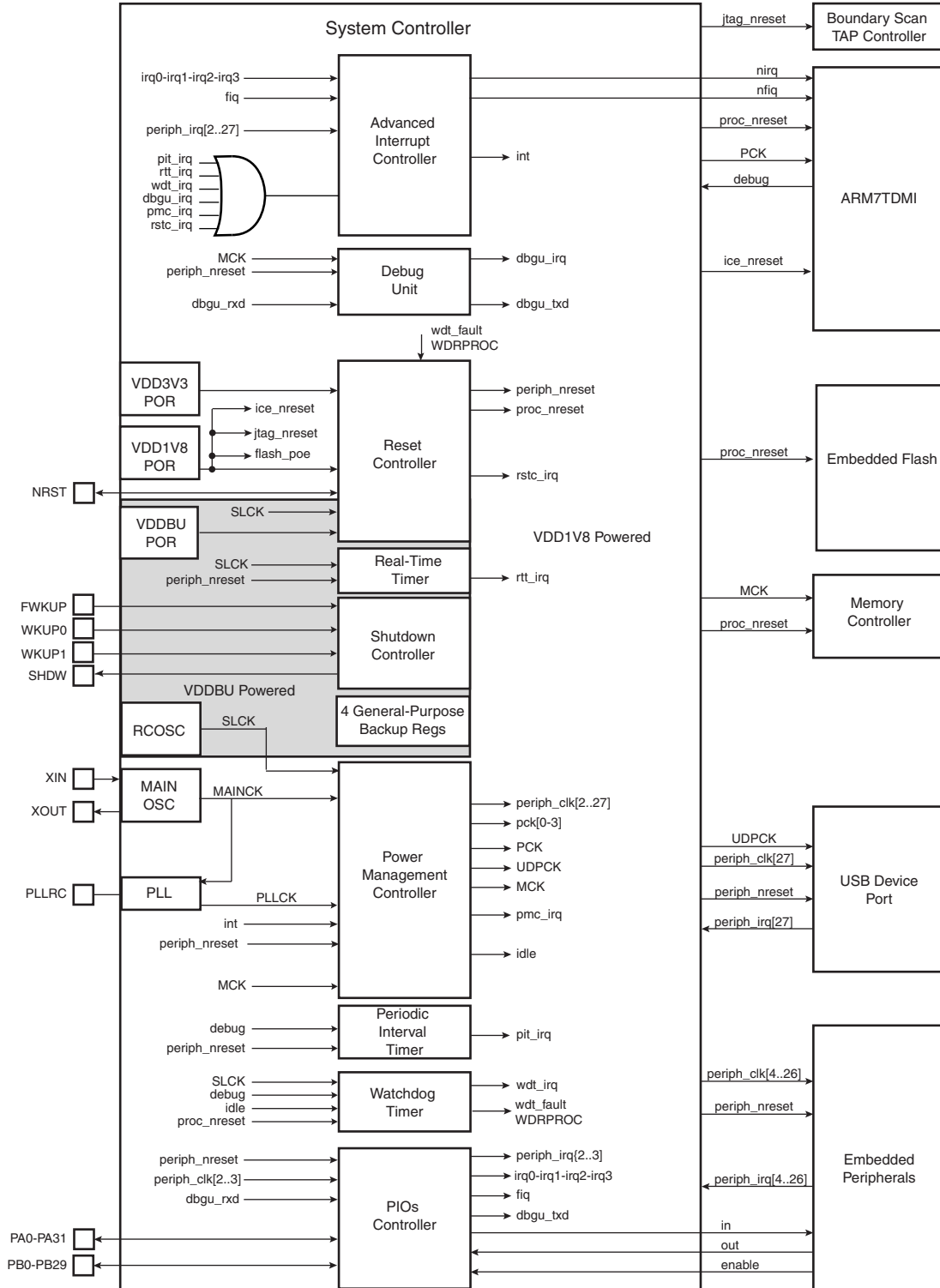

## 9.1 System Controller Mapping

The System Controller peripherals are all mapped to the highest 4K bytes of address space, between addresses 0xFFFF F000 and 0xFFFF FFFF. Each peripheral has an address space of up to 512 Bytes, representing up to 128 registers.

Figure 9-2 shows the mapping of the System Controller and of the Memory Controller

Figure 9-2. System Controller Mapping

Address	Peripheral	Peripheral Name	Size
0xFFFF F000	AIC	Advanced Interrupt Controller	512 Bytes/128 registers
0xFFFF F1FF 0xFFFF F200	DBGU	Debug Unit	512 Bytes/128 registers
0xFFFF F3FF 0xFFFF F400	PIOA	PIO Controller A	512 Bytes/128 registers
0xFFFF F5FF 0xFFFF F600	PIOB	PIO Controller B	512 Bytes/128 registers
0xFFFF F7FF 0xFFFF F800	Reserved		
0xFFFF FBFF 0xFFFF FC00	PMC	Power Management Controller	256 Bytes/64 registers
0xFFFF FCFF 0xFFFF FD00 0xFFFF FD0F	RSTC	Reset Controller	16 Bytes/4 registers
0xFFFF FD10 0xFFFF FD1F	SHDWC	Shutdown Controller	16 Bytes/4 registers
0xFFFF FD20 0xFFFF FD2F	RTT	Real-time Timer	16 Bytes/4 registers
0xFFFF FD30 0xFFFF FD3F	PIT	Periodic Interval Timer	16 Bytes/4 registers
0xFFFF FD40 0xFFFF FD4F	WDT	Watchdog Timer	16 Bytes/4 registers
	Reserved		
0xFFFF FD60 0xFFFF FD6F 0xFFFF FD50	GPBR	General Purpose Backup Registers	8 Bytes/2 registers
0xFFFF FD58	Reserved		
0xFFFF FF00	MC	Memory Controller	256 Bytes/64 registers
0xFFFF FFFF			

## 9.2 Reset Controller

The Reset Controller is based on three power-on reset cells. It gives the status of the last reset, indicating whether it is a general reset, a wake-up reset, a software reset, a user reset or a watchdog reset. In addition, it controls the internal resets and the NRST pin output. It shapes a signal on the NRST line, guaranteeing that the length of the pulse meets any requirement.

## 9.3 Clock Generator

The Clock Generator embeds one low-power RC Oscillator, one Main Oscillator and one PLL with the following characteristics:

- RC Oscillator ranges between 22 KHz and 42 KHz
- Main Oscillator frequency ranges between 3 and 20 MHz
- Main Oscillator can be bypassed
- PLL output ranges between 80 and 220 MHz

It provides SLCK, MAINCK and PLLCK.

**Figure 9-3.** Clock Generator Block Diagram

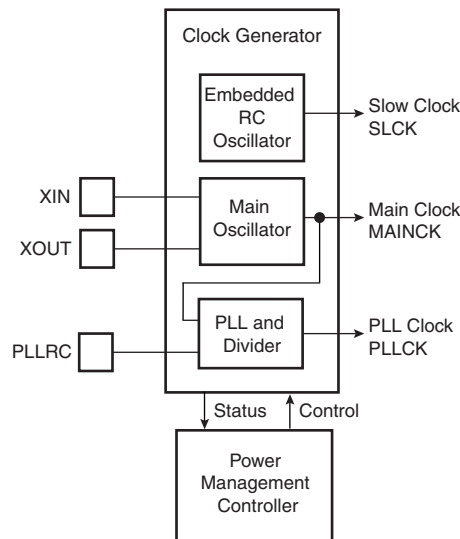

## 9.4 Power Management Controller

The Power Management Controller uses the Clock Generator outputs to provide:

- the Processor Clock PCK
- the Master Clock MCK
- the USB Clock UDPCK
- all the peripheral clocks, independently controllable
- four programmable clock outputs

The Master Clock (MCK) is programmable from a few hundred Hz to the maximum operating frequency of the device.

The Processor Clock (PCK) switches off when entering processor idle mode, thereby reducing power consumption while waiting an interrupt.

**Figure 9-4.** Power Management Controller Block Diagram

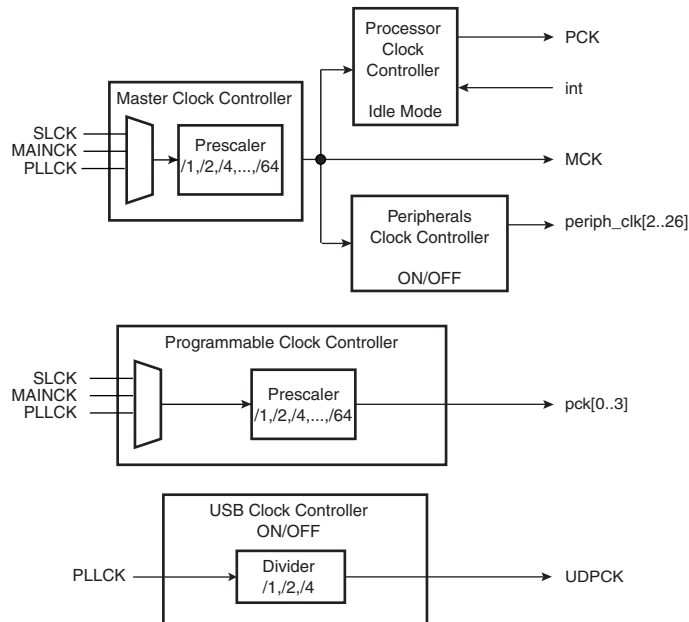

## 9.5 Advanced Interrupt Controller

- Controls the interrupt lines (nIRQ and nFIQ) of the ARM Processor
- Individually maskable and vectored interrupt sources
  - Source 0 is reserved for the Fast Interrupt Input (FIQ)
  - Source 1 is reserved for system peripherals (ST, PMC, DBGU, etc.)
  - Other sources control the peripheral interrupts or external interrupts
  - Programmable edge-triggered or level-sensitive internal sources
  - Programmable positive/negative edge-triggered or high/low level-sensitive external sources (FIQ, IRQ)
- 8-level Priority Controller
  - Drives the normal interrupt nIRQ of the processor
  - Handles priority of the interrupt sources
  - Higher priority interrupts can be served during service of a lower priority interrupt
- Vectoring
  - Optimizes interrupt service routine branch and execution
  - One 32-bit vector register per interrupt source
  - Interrupt vector register reads the corresponding current interrupt vector
- Protect Mode
  - Easy debugging by preventing automatic operations
- Fast Forcing
  - Permits redirecting any interrupt source on the fast interrupt
- General Interrupt Mask
  - Provides processor synchronization on events without triggering an interrupt

## 9.6 Debug Unit

- Comprises
  - One two-pin UART
  - One interface for the Debug Communication Channel (DCC) support
  - One set of chip ID registers
  - One interface allowing ICE access prevention
- Two-pin UART
  - USART-compatible user interface
  - Programmable baud rate generator
  - Parity, framing and overrun error
  - Automatic Echo, Local Loopback and Remote Loopback Channel Modes
- Debug Communication Channel Support
  - Offers visibility of COMMRX and COMMTX signals from the ARM Processor
- Chip ID Registers
  - Identification of the device revision, sizes of the embedded memories, set of peripherals
  - Chip ID is 0x260A0941 (Version 1)

## 9.7 Period Interval Timer

- 20-bit programmable counter plus 12-bit interval counter

## 9.8 Watchdog Timer

- 12-bit key-protected Programmable Counter running on prescaled SLCK
- Provides reset or interrupt signals to the system
- Counter may be stopped while the processor is in debug state or in idle mode

## 9.9 Real-time Timer

- 32-bit free-running counter with alarm
- Programmable 16-bit prescaler for SCLK accuracy compensation

## 9.10 Shutdown Controller

- Software programmable assertion of the SHDW open-drain pin
- De-assertion programmable with the pins WKUP0, WKUP1 and FWKUP

## 9.11 PIO Controllers A and B

- The PIO Controllers A and B respectively control 32 and 30 programmable I/O Lines
- Fully programmable through Set/Clear Registers
- Multiplexing of two peripheral functions per I/O Line
- For each I/O Line (whether assigned to a peripheral or used as general purpose I/O)
  - Input change interrupt
  - Half a clock period Glitch filter
  - Multi-drive option enables driving in open drain

- Programmable pull up on each I/O line
- Pin data status register, supplies visibility of the level on the pin at any time
- Synchronous output, provides Set and Clear of several I/O lines in a single write

## 10. Peripherals

### 10.1 Peripheral Mapping

Each User Peripheral is allocated 16K bytes of address space.

**Figure 10-1.** User Peripherals Mapping

Address	Peripheral	Peripheral Name	Size
0xF000 0000	Reserved		
0xFFFB 0000	CAN0	CAN Controller 0	16K Bytes
0xFFFB 4000	CAN1	CAN Controller 1	16K Bytes
0xFFFB 8000	Reserved		
0xFFFA 0000	TC0, TC1, TC2	Timer/Counter 0, 1 and 2	16K Bytes
0xFFFA 4000	TC3, TC4, TC5	Timer/Counter 3, 4 and 5	16K Bytes
0xFFFA 8000	TC6, TC7, TC8	Timer/Counter 6, 7 and 8	16K Bytes
0xFFFA C000	MCI	Multimedia Card Interface	16K Bytes
0xFFFA 0000	UDP	USB Device Port	16K Bytes
0xFFFB 0000	Reserved		
0xFFFB 8000	TWI	Two-Wire Interface	16K Bytes
0xFFFB C000	Reserved		
0xFFFB 0000	USART0	Universal Synchronous Asynchronous Receiver Transmitter 0	16K Bytes
0xFFFB 4000	USART1	Universal Synchronous Asynchronous Receiver Transmitter 1	16K Bytes
0xFFFB 8000	USART2	Universal Synchronous Asynchronous Receiver Transmitter 1	16K Bytes
0xFFFB C000	PWMC	PWM Controller	16K Bytes
0xFFFD 0000	SSC0	Serial Synchronous Controller 0	16K Bytes
0xFFFD 4000	SSC1	Serial Synchronous Controller 1	16K Bytes
0xFFFD 8000	ADC0	Analog-to-Digital Converter 0	16K Bytes
0xFFFD C000	ADC1	Analog-to-Digital Converter 1	16K Bytes
0xFFFE 0000	SPI0	Serial Peripheral Interface 0	16K Bytes
0xFFFE 4000	SPI1	Serial Peripheral Interface 1	16K Bytes
0xFFFE 8000	Reserved		
0xFFFE FFFF			

## 10.2 Peripheral Multiplexing on PIO Lines

The AT91SAM7A3 features two PIO controllers, PIOA and PIOB, which multiplex the I/O lines of the peripheral set.

PIO Controllers A and B control respectively 32 and 30 lines. Each line can be assigned to one of two peripheral functions, A or B. Some of them can also be multiplexed with Analog Input of both ADC Controllers.

[Table 10-1 on page 24](#) and [Table 10-2 on page 25](#) define how the I/O lines of the peripherals A, B or Analog Input are multiplexed on the PIO Controllers A and B. The two columns “Function” and “Comments” have been inserted for the user’s own comments; they may be used to track how pins are defined in an application.

Note that some peripheral functions that are output only may be duplicated within both tables.

At reset, all I/O lines are automatically configured as input with the programmable pull-up enabled, so that the device is maintained in a static state as soon as a reset occurs.

### 10.3 PIO Controller A Multiplexing

**Table 10-1.** Multiplexing on PIO Controller A

PIO Controller A				Application Usage	
I/O Line	Peripheral A	Peripheral B	Comment	Function	Comments
PA0	TWD	ADC0_ADTRG			
PA1	TWCK	ADC1_ADTRG			
PA2	RXD0				
PA3	TXD0				
PA4	SCK0	SPI1_NPSC0			
PA5	RTS0	SPI1_NPCS1			
PA6	CTS0	SPI1_NPCS2			
PA7	RXD1	SPI1_NPCS3			
PA8	TXD1	SPI1_MISO			
PA9	RXD2	SPI1_MOSI			
PA10	TXD2	SPI1_SPCK			
PA11	SPI0_NPCS0				
PA12	SPI0_NPCS1	MCDA1			
PA13	SPI0_NPCS2	MCDA2			
PA14	SPI0_NPCS3	MCDA3			
PA15	SPI0_MISO	MCD A0			
PA16	SPI0_MOSI	MCCDA			
PA17	SPI0_SPCK	MCCK			
PA18	PWM0	PCK0			
PA19	PWM1	PCK1			
PA20	PWM2	PCK2			
PA21	PWM3	PCK3			
PA22	PWM4	IRQ0			
PA23	PWM5	IRQ1			
PA24	PWM6	TCLK4			
PA25	PWM7	TCLK5			
PA26	CANRX0				
PA27	CANTX0				
PA28	CANRX1	TCLK3			
PA29	CANTX1	TCLK6			
PA30	DRXD	TCLK7			
PA31	DTXD	TCLK8			

## 10.4 PIO Controller B Multiplexing

**Table 10-2.** Multiplexing on PIO Controller B

PIO Controller B				Application Usage	
I/O Line	Peripheral A	Peripheral B	Comment	Function	Comments
PB0	IRQ2	PWM5			
PB1	IRQ3	PWM6			
PB2	TF0	PWM7			
PB3	TK0	PCK0			
PB4	TD0	PCK1			
PB5	RD0	PCK2			
PB6	RK0	PCK3			
PB7	RF0	CANTX1			
PB8	FIQ	TF1			
PB9	TCLK0	TK1			
PB10	TCLK1	RK1			
PB11	TCLK2	RF1			
PB12	TIOA0	TD1			
PB13	TIOB0	RD1			
PB14	TIOA1	PWM0	ADC0_AD0		
PB15	TIOB1	PWM1	ADC0_AD1		
PB16	TIOA2	PWM2	ADC0_AD2		
PB17	TIOB2	PWM3	ADC0_AD3		
PB18	TIOA3	PWM4	ADC0_AD4		
PB19	TIOB3	SPI1_NPCS1	ADC0_AD5		
PB20	TIOA4	SPI1_NPCS2	ADC0_AD6		
PB21	TIOB4	SPI1_NPCS3	ADC0_AD7		
PB22	TIOA5		ADC1_AD0		
PB23	TIOB5		ADC1_AD1		
PB24	TIOA6	RTS1	ADC1_AD2		
PB25	TIOB6	CTS1	ADC1_AD3		
PB26	TIOA7	SCK1	ADC1_AD4		
PB27	TIOB7	RTS2	ADC1_AD5		
PB28	TIOA8	CTS2	ADC1_AD6		
PB29	TIOB8	SCK2	ADC1_AD7		



## 11. Peripheral Identifiers

The AT91SAM7A3 embeds a wide range of peripherals. [Table 11-1](#) defines the Peripheral Identifiers of the AT91SAM7A3. Unique peripheral identifiers are defined for both the AIC and the PMC.

**Table 11-1.** Peripheral Identifiers

Peripheral ID	Peripheral Mnemonic	Peripheral Name	External Interrupt
0	AIC	Advanced Interrupt Controller	FIQ
1	SYSIRQ <sup>(1)</sup>		
2	PIOA	Parallel I/O Controller A	
3	PIOB	Parallel I/O Controller B	
4	CAN0	CAN Controller 0	
5	CAN1	CAN Controller 1	
6	US0	USART 0	
7	US1	USART 1	
8	US2	USART 2	
9	MCI	Multimedia Card Interface	
10	TWI	Two-wire Interface	
11	SPI0	Serial Peripheral Interface 0	
12	SPI1	Serial Peripheral Interface 1	
13	SSC0	Synchronous Serial Controller 0	
14	SSC1	Synchronous Serial Controller 1	
15	TC0	Timer/Counter 0	
16	TC1	Timer/Counter 1	
17	TC2	Timer/Counter 2	
18	TC3	Timer/Counter 3	
19	TC4	Timer/Counter 4	
20	TC5	Timer/Counter 5	
21	TC6	Timer/Counter 6	
22	TC7	Timer/Counter 7	
23	TC8	Timer/Counter 8	
24	ADC0 <sup>(1)</sup>	Analog-to Digital Converter 0	
25	ADC1 <sup>(1)</sup>	Analog-to Digital Converter 1	
26	PWMC	PWM Controller	
27	UDP	USB Device Port	
28	AIC	Advanced Interrupt Controller	IRQ0
29	AIC	Advanced Interrupt Controller	IRQ1
30	AIC	Advanced Interrupt Controller	IRQ2
31	AIC	Advanced Interrupt Controller	IRQ3

Note: 1. Setting SYSIRQ and ADC bits in the clock set/clear registers of the PMC has no effect. The System Controller and ADC are continuously clocked.

## 11.1 Serial Peripheral Interface

- Supports communication with external serial devices
  - Four chip selects with external decoder allow communication with up to 15 peripherals
  - Serial memories, such as DataFlash® and 3-wire EEPROMs
  - Serial peripherals, such as ADCs, DACs, LCD Controllers, CAN Controllers and Sensors
  - External co-processors
- Master or slave serial peripheral bus interface
  - 8- to 16-bit programmable data length per chip select
  - Programmable phase and polarity per chip select
  - Programmable transfer delays per chip select between consecutive transfers and between clock and data
  - Programmable delay between consecutive transfers
  - Selectable mode fault detection
  - Maximum frequency at up to Master Clock

## 11.2 Two-wire Interface

- Master Mode only
- Compatibility with standard two-wire serial memories
- One, two or three bytes for slave address
- Sequential read/write operations

## 11.3 USART

- Programmable Baud Rate Generator
- 5- to 9-bit full-duplex synchronous or asynchronous serial communications
  - 1, 1.5 or 2 stop bits in Asynchronous Mode or 1 or 2 stop bits in Synchronous Mode
  - Parity generation and error detection
  - Framing error detection, overrun error detection
  - MSB- or LSB-first
  - Optional break generation and detection
  - By 8 or by 16 over-sampling receiver frequency
  - Hardware handshaking RTS-CTS
  - Receiver time-out and transmitter timeguard
  - Optional Multi-drop Mode with address generation and detection
- RS485 with driver control signal
- ISO7816, T = 0 or T = 1 Protocols for interfacing with smart cards
  - NACK handling, error counter with repetition and iteration limit
- IrDA modulation and demodulation
  - Communication at up to 115.2 Kbps
- Test Modes

- Remote Loopback, Local Loopback, Automatic Echo

## 11.4 Serial Synchronous Controller

- Provides serial synchronous communication links used in audio and telecom applications
- Contains an independent receiver and transmitter and a common clock divider
- Offers a configurable frame sync and data length
- Receiver and transmitter can be programmed to start automatically or on detection of different event on the frame sync signal
- Receiver and transmitter include a data signal, a clock signal and a frame synchronization signal

## 11.5 Timer Counter

- Three 16-bit Timer Counter Channels
- Wide range of functions including:
  - Frequency Measurement
  - Event Counting
  - Interval Measurement
  - Pulse Generation
  - Delay Timing
  - Pulse Width Modulation
  - Up/down Capabilities
- Each channel is user-configurable and contains:
  - Three external clock inputs
  - Five internal clock inputs as defined in [Table 11-2](#).

**Table 11-2.** Timer Counter Clock Assignment

TC Clock input	Clock
TIMER_CLOCK1	MCK/2
TIMER_CLOCK2	MCK/8
TIMER_CLOCK3	MCK/32
TIMER_CLOCK4	MCK/128
TIMER_CLOCK5	MCK/1024

- Two multi-purpose input/output signals
- Two global registers that act on all three TC Channels

## 11.6 PWM Controller

- Eight channels, one 20-bit counter per channel
- Common clock generator, providing thirteen different clocks
  - A Modulo n counter providing eleven clocks
  - Two independent linear dividers working on modulo n counter outputs
- Independent channel programming

- Independent enable/disable commands
- Independent clock selection
- Independent period and duty cycle, with double buffering
- Programmable selection of the output waveform polarity
- Programmable center or left aligned output waveform

## 11.7 USB Device Port

- USB V2.0 full-speed compliant, 12 Mbits per second.
- Embedded USB V2.0 full-speed transceiver
- Six endpoints
  - Endpoint 0: 8 bytes
  - Endpoint 1 and 2: 64 bytes ping-pong
  - Endpoint 3: 64 bytes
  - Endpoint 4 and 5: 512 bytes ping-pong
- Embedded 2,376-byte dual-port RAM for endpoints
  - Ping-pong Mode (two memory banks) for bulk endpoints
- Suspend/resume logic

## 11.8 Multimedia Card Interface

- Compatibility with MultiMedia card specification version 2.2
- Compatibility with SD Memory card specification version 1.0
- Cards clock rate up to Master Clock divided by 2
- Embeds power management to slow down clock rate when not used
- Supports up to sixteen slots (through multiplexing)
  - One slot for one MultiMedia card bus (up to 30 cards) or one SD memory card
- Supports stream, block and multi-block data read and write
- Supports connection to Peripheral Data Controller
  - Minimizes processor intervention for large buffer transfers

## 11.9 CAN Controller

- Fully compliant with CAN 2.0B active controllers
- Bit rates up to 1Mbit/s
- 16 object-oriented mailboxes, each with the following properties:
  - CAN specification 2.0 Part A or 2.0 Part B programmable for each message
  - Object-configurable as receive (with overwrite or not) or transmit
  - Local tag and mask filters up to 29-bit identifier/channel
  - 32-bit access to data registers for each mailbox data object
  - Uses a 16-bit time stamp on receive and transmit messages
  - Hardware concatenation of ID unmasked bit fields to speed up family ID processing
  - 16-bit internal timer for Time Stamping and Network synchronization

- Programmable reception buffer length up to 16 mailbox object
- Priority management between transmission mailboxes
- Autobaud and listening mode
- Low power mode and programmable wake-up on bus activity or by the application
- Data, remote, error and overload frame handling

### 11.10 Analog-to-Digital Converter

- 8-channel ADC
- 10-bit 384K samples/sec Successive Approximation Register ADC
- -3/+3 LSB Integral Non Linearity, -2/+2 LSB Differential Non Linearity
- Integrated 8-to-1 multiplexer, offering eight independent 3.3V analog inputs
- Individual enable and disable of each channel
- External voltage reference for better accuracy on low-voltage inputs
- Multiple trigger sources
  - Hardware or software trigger
  - External pins: ADTRG0 and ADTRG1
  - Timer Counter 0 to 5 outputs: TIOA0 to TIOA5
- Sleep Mode and conversion sequencer
  - Automatic wakeup on trigger and back to sleep mode after conversions of all enabled channels
- All analog inputs are shared with digital signals

## 12. Ordering Information

Table 12-1. Ordering Information

Ordering Code	Package	Package Type	Temperature Operating Range
AT91SAM7A3-AU	LQFP100	Green	Industrial (-40°C to 85°C)



## 13. Document Details

### Title

AT91SAM7A3 Summary

### Literature Number

6042S

## 13.1 Revision History

### 13.1.1 Version A

Publication Date: 23-Dec-04

### 13.1.2 Version B

Publication Date: 30-Sep-05

**Table 13-1.** Revision History

Page	Comments	Change Request Ref.
1	In Features, corrected number of battery backup registers. Updated Page Programming Time.	05-232
2	Changed information on static operation.	
4, 5 and others	Changed signal names VDDIN and VDDIO to VDD3V3 and VDDOUT and VDDCORE to VDD1V8. Removed signal names GNDANA, GNDBU and GNDPLL in <a href="#">Figure 2-1</a> , <a href="#">“AT91SAM7A3 Block Diagram”</a> , <a href="#">Table 3-1</a> , <a href="#">“Signal Description”</a> and <a href="#">Table 4-1</a> , <a href="#">“Pinout in 100-lead LQFP Package”</a> . Changed SPI and ADC signal names.	
9	Updated <a href="#">Section 5.1 on page 9</a> with new signal names and new information.	
10	Updated <a href="#">Figure 5-1</a> , <a href="#">“3.3V System Single Power Supply Schematics”</a> with new signal names.	
14	Updated <a href="#">Section 8.1 “Embedded Memories” on page 14</a> with correct lock region size.	05-440
15	Updated <a href="#">Section 8.3 on page 15</a> with information on standby mode for Flash.	
16	Updated <a href="#">Figure 9-1</a> , <a href="#">“System Controller Block Diagram”</a> with new signal names. Corrected addresses.	
17	Corrected start and end addresses of GPBR in <a href="#">Figure 9-2</a> , <a href="#">“System Controller Mapping”</a> .	05-234
20	Updated chip ID reference in <a href="#">“Debug Unit”</a> .	
31	Updated <a href="#">Table 12-1</a> , <a href="#">“Ordering Information”</a> with new ordering information.	



## Atmel Corporation

2325 Orchard Parkway  
San Jose, CA 95131, USA  
Tel: 1(408) 441-0311  
Fax: 1(408) 487-2600

## Regional Headquarters

### Europe

Atmel Sarl  
Route des Arsenaux 41  
Case Postale 80  
CH-1705 Fribourg  
Switzerland  
Tel: (41) 26-426-5555  
Fax: (41) 26-426-5500

### Asia

Room 1219  
Chinachem Golden Plaza  
77 Mody Road Tsimshatsui  
East Kowloon  
Hong Kong  
Tel: (852) 2721-9778  
Fax: (852) 2722-1369

### Japan

9F, Tonetsu Shinkawa Bldg.  
1-24-8 Shinkawa  
Chuo-ku, Tokyo 104-0033  
Japan  
Tel: (81) 3-3523-3551  
Fax: (81) 3-3523-7581

## Atmel Operations

### Memory

2325 Orchard Parkway  
San Jose, CA 95131, USA  
Tel: 1(408) 441-0311  
Fax: 1(408) 436-4314

### Microcontrollers

2325 Orchard Parkway  
San Jose, CA 95131, USA  
Tel: 1(408) 441-0311  
Fax: 1(408) 436-4314

La Chantrerie  
BP 70602  
44306 Nantes Cedex 3, France  
Tel: (33) 2-40-18-18-18  
Fax: (33) 2-40-18-19-60

### ASIC/ASSP/Smart Cards

Zone Industrielle  
13106 Rousset Cedex, France  
Tel: (33) 4-42-53-60-00  
Fax: (33) 4-42-53-60-01

1150 East Cheyenne Mtn. Blvd.  
Colorado Springs, CO 80906, USA  
Tel: 1(719) 576-3300  
Fax: 1(719) 540-1759

Scottish Enterprise Technology Park  
Maxwell Building  
East Kilbride G75 0QR, Scotland  
Tel: (44) 1355-803-000  
Fax: (44) 1355-242-743

### RF/Automotive

Theresienstrasse 2  
Postfach 3535  
74025 Heilbronn, Germany  
Tel: (49) 71-31-67-0  
Fax: (49) 71-31-67-2340

1150 East Cheyenne Mtn. Blvd.  
Colorado Springs, CO 80906, USA  
Tel: 1(719) 576-3300  
Fax: 1(719) 540-1759

### Biometrics/Imaging/Hi-Rel MPU/ High Speed Converters/RF Datacom

Avenue de Rochepleine  
BP 123  
38521 Saint-Egreve Cedex, France  
Tel: (33) 4-76-58-30-00  
Fax: (33) 4-76-58-34-80



## Literature Requests

[www.atmel.com/literature](http://www.atmel.com/literature)

**Disclaimer:** The information in this document is provided in connection with Atmel products. No license, express or implied, by estoppel or otherwise, to any intellectual property right is granted by this document or in connection with the sale of Atmel products. **EXCEPT AS SET FORTH IN ATMEL'S TERMS AND CONDITIONS OF SALE LOCATED ON ATMEL'S WEB SITE, ATMEL ASSUMES NO LIABILITY WHATSOEVER AND DISCLAIMS ANY EXPRESS, IMPLIED OR STATUTORY WARRANTY RELATING TO ITS PRODUCTS INCLUDING, BUT NOT LIMITED TO, THE IMPLIED WARRANTY OF MERCHANTABILITY, FITNESS FOR A PARTICULAR PURPOSE, OR NON-INFRINGEMENT. IN NO EVENT SHALL ATMEL BE LIABLE FOR ANY DIRECT, INDIRECT, CONSEQUENTIAL, PUNITIVE, SPECIAL OR INCIDENTAL DAMAGES (INCLUDING, WITHOUT LIMITATION, DAMAGES FOR LOSS OF PROFITS, BUSINESS INTERRUPTION, OR LOSS OF INFORMATION) ARISING OUT OF THE USE OR INABILITY TO USE THIS DOCUMENT, EVEN IF ATMEL HAS BEEN ADVISED OF THE POSSIBILITY OF SUCH DAMAGES.** Atmel makes no representations or warranties with respect to the accuracy or completeness of the contents of this document and reserves the right to make changes to specifications and product descriptions at any time without notice. Atmel does not make any commitment to update the information contained herein. Unless specifically provided otherwise, Atmel products are not suitable for, and shall not be used in, automotive applications. Atmel's products are not intended, authorized, or warranted for use as components in applications intended to support or sustain life.

© Atmel Corporation 2005. All rights reserved. Atmel®, logo and combinations thereof, Everywhere You Are® and DataFlash® and others are the registered trademarks or trademarks of Atmel Corporation or its subsidiaries. ARM®, Thumb®, ARM7TDMI®, ARMPowered® and ARM7® are registered trademarks of ARM Ltd. Other terms and product names may be the trademarks of others.



Printed on recycled paper.

6042BS-ATARM-30-Sep-05