

QTP-208E-M01

<p>208-pin plastic QTP</p>  <p>(QTP-208E-M01)</p>	Lead pitch	0.30 mm
	Package width × package length	20.00 × 20.00 mm
	Sealing method	Resin seal

208-pin plastic QTP
(QTP-208E-M01)

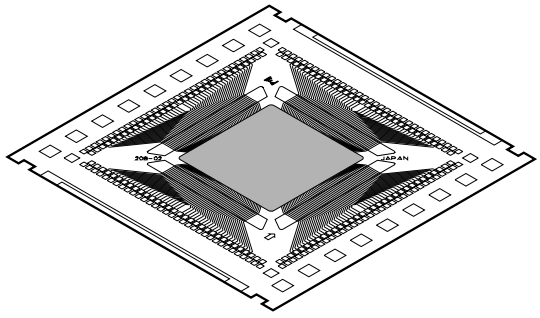
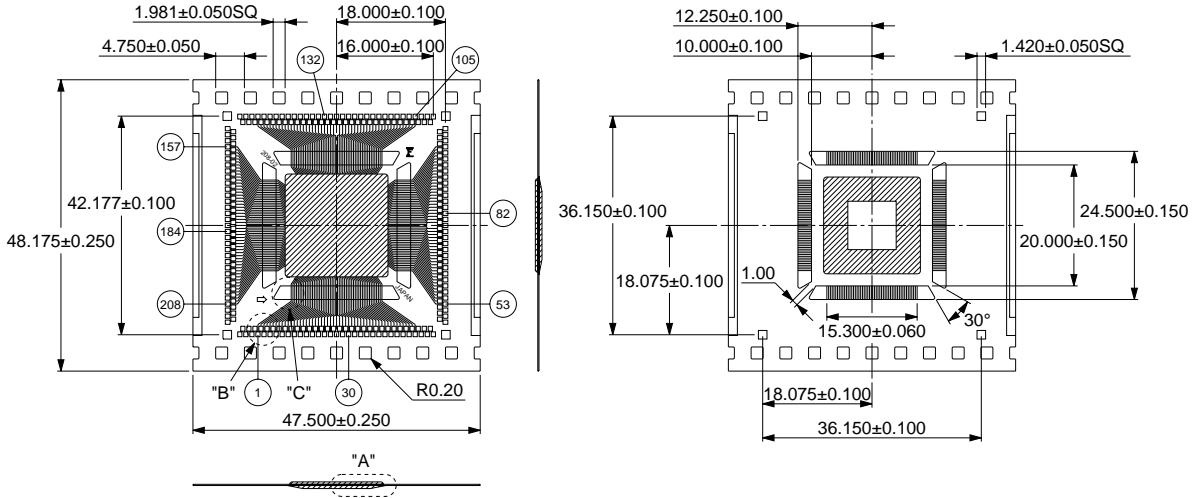

Details of "A" part

0.20-0.70 0.35-0.55
8.100±0.500 0.125±0.013
S T
8.600MAX

Details of "B" part

0.925±0.035 0.800±0.050
1.000±0.035 0.700±0.050
0.500±0.035

Details of "C" part

0.300±0.030 0.120±0.040

Note 1. Part "T" indicates the lead (Cu); thickness:20 min.
Note 2. Part "S" indicates the adhesive; thickness:20±4 μm.

© 1997 FUJITSU LIMITED TC208002S-2C-2

Dimensions in mm (inches).

The contents of this document are subject to change without notice.
Customers are advised to consult with FUJITSU sales representatives before ordering.
FUJITSU is unable to assume responsibility for infringement of any patent rights or other rights of third parties arising from the use of the information or package dimensions in this document.