

LCC-20P-M02

<p>20-pin plastic QFJ (PLCC)</p>  <p>(LCC-20P-M02)</p>	Lead pitch	50 mil	
	Package width × package length	353 × 353 mil	
	Lead shape	J bend	
	Sealing method	Plastic mold	

20-pin plastic QFJ (PLCC)  
(LCC-20P-M02)

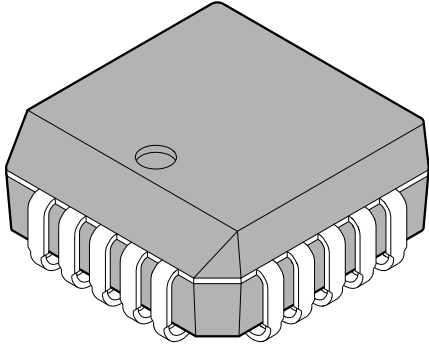
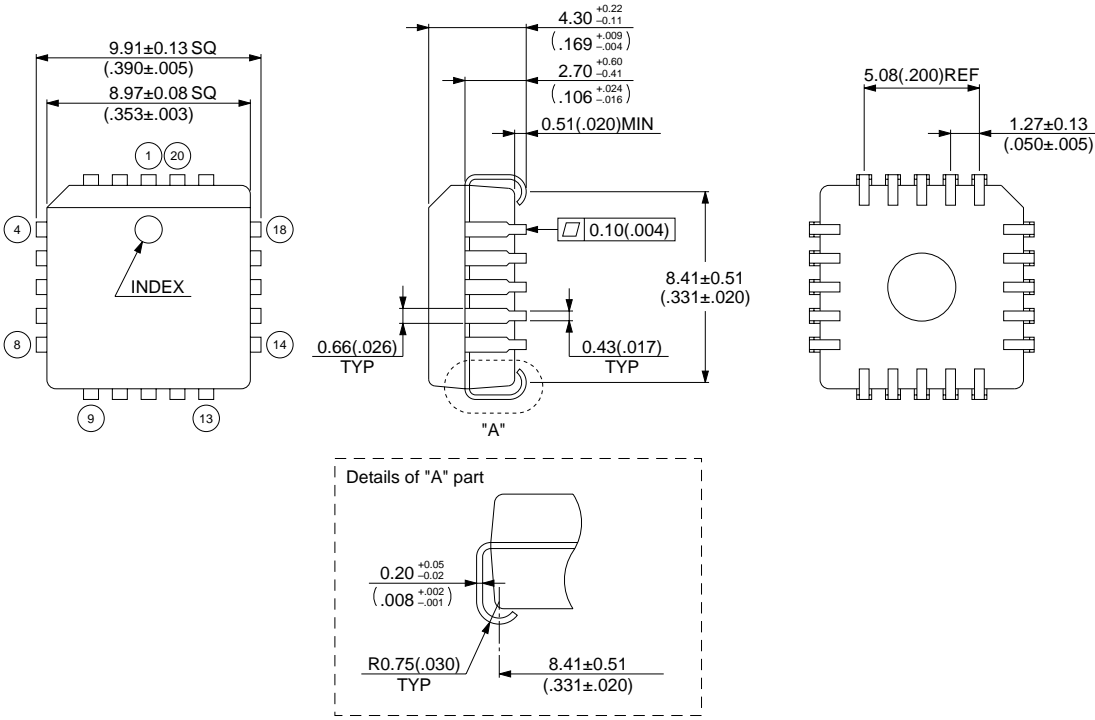

Top view dimensions:  
 9.91±0.13 SQ (.390±.005)  
 8.97±0.08 SQ (.353±.003)  
 INDEX

Side view dimensions:  
 4.30<sup>+0.22</sup>/<sub>-0.11</sub> (.169<sup>+0.009</sup>/<sub>-.004</sub>)  
 2.70<sup>+0.60</sup>/<sub>-0.41</sub> (.106<sup>+0.024</sup>/<sub>-.016</sub>)  
 0.51(.020)MIN  
 0.66(.026) TYP  
 0.43(.017) TYP  
 8.41±0.51 (.331±.020)  
 "A"

Detail of "A" part:  
 0.20<sup>+0.05</sup>/<sub>-0.02</sub> (.008<sup>+0.002</sup>/<sub>-.001</sub>)  
 R0.75(.030) TYP  
 8.41±0.51 (.331±.020)

Other dimensions:  
 5.08(.200)REF  
 1.27±0.13 (.050±.005)

© 1994 FUJITSU LIMITED C20053S-2C-2

Ⓝ : LEAD No.  
Dimensions in mm (inches).

The contents of this document are subject to change without notice.  
 Customers are advised to consult with FUJITSU sales representatives before ordering.  
 FUJITSU is unable to assume responsibility for infringement of any patent rights or other rights of third parties arising from the use of the information or package dimensions in this document.