

USBN9603/USBN9604 Universal Serial Bus Full Speed Node Controller with Enhanced DMA Support

General Description

The USBN9603/4 are integrated, USB Node controllers. Other than the reset mechanism for the clock generation circuit, these two devices are identical. All references to "the device" in this document refer to both devices, unless otherwise noted.

The device provides enhanced DMA support with many automatic data handling features. It is compatible with USB specification versions 1.0 and 1.1, and is an advanced version of the USBN9602.

The device integrates the required USB transceiver with a 3.3V regulator, a Serial Interface Engine (SIE), USB endpoint (EP) FIFOs, a versatile 8-bit parallel interface, a clock generator and a MICROWIRE/PLUS™ interface. Seven endpoint pipes are supported: one for the mandatory control endpoint and six to support interrupt, bulk and isochronous endpoints. Each endpoint pipe has a dedicated FIFO, 8 bytes for the control endpoint and 64 bytes for the other endpoints. The 8-bit parallel interface supports multiplexed and non-multiplexed style CPU address/data buses. A programmable interrupt output scheme allows device configuration for different interrupt signaling requirements.

Outstanding Features

- Low EMI, low standby current, 24 MHz oscillator
- Advanced DMA mechanism
- Fully static HALT mode with asynchronous wake-up for bus powered operation
- 5V or 3.3V operation
- Improved input range 3.3V signal voltage regulator
- All unidirectional FIFOs are 64 bytes
- Power-up reset and startup delay counter simplify system design
- Simple programming model controlled by external controller
- Available in two packages
 - USBN9603/4SLB: small footprint for new designs and portable applications
 - USBN9603/4-28M: standard package, pin-to-pin compatible with USBN9602-28M

Block Diagram

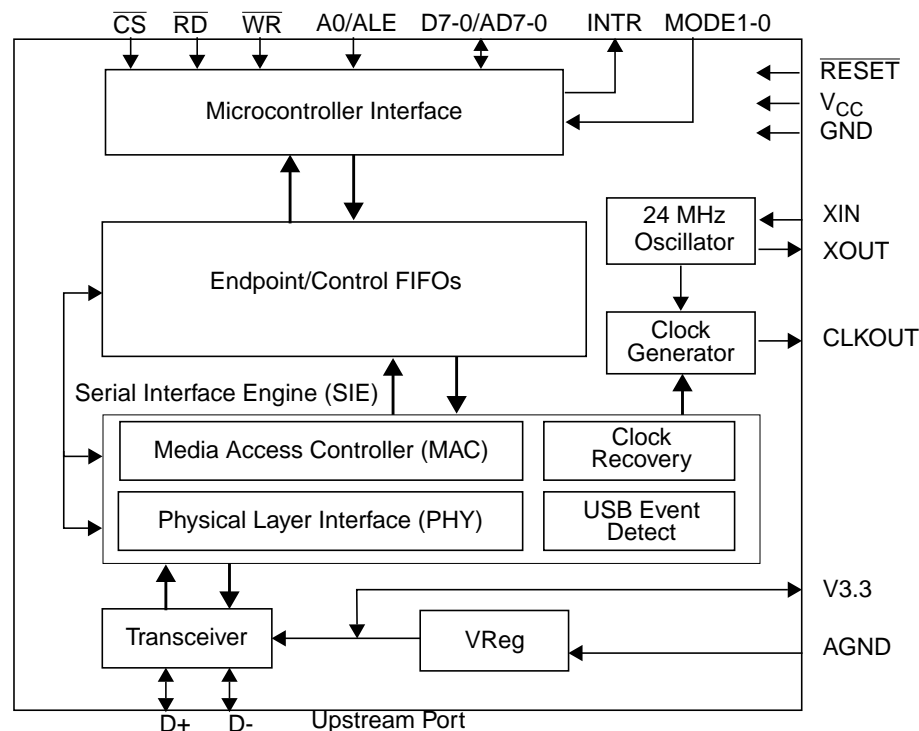

Features

- Full-speed USB node device
- Integrated USB transceiver
- Supports 24 MHz oscillator circuit with internal 48 MHz clock generation circuit
- Programmable clock generator
- Serial Interface Engine (SIE) consisting of Physical Layer Interface (PHY) and Media Access Controller (MAC), USB Specification 1.0 and 1.1 compliant
- Control/Status register file
- USB Function Controller with seven FIFO-based End-points:
 - One bidirectional Control Endpoint 0 (8 bytes)
 - Three Transmit Endpoints (64 bytes each)
 - Three Receive Endpoints (64 bytes each)
- 8-bit parallel interface with two selectable modes:
 - Non-multiplexed
 - Multiplexed (Intel compatible)
- Enhanced DMA support
 - Automatic DMA (ADMA) mode for fully CPU-independent transfer of large bulk or ISO packets
 - DMA controller, together with the ADMA logic, can transfer a large block of data in 64-byte packets via the USB
 - Automatic Data PID toggling/checking and NAK packet recovery (maximum 256x64 bytes of data = 16K bytes)
- MICROWIRE/PLUS interface

Table of Contents

1.0 Signal/Pin Connection and Description

1.1	CONNECTION DIAGRAMS	6
1.2	DETAILED SIGNAL/PIN DESCRIPTIONS	7
1.2.1	Power Supply	7
1.2.2	Oscillator, Clock and Reset	7
1.2.3	USB Port	8
1.2.4	Microprocessor Interface	8

2.0 Functional Overview

2.1	TRANSCEIVER	10
2.2	VOLTAGE REGULATOR (VREG)	10
2.3	SERIAL INTERFACE ENGINE (SIE)	10
2.4	ENDPOINT PIPE CONTROLLER (EPC)	12
2.5	MICROCONTROLLER INTERFACE	12

3.0 Parallel Interface

3.1	NON-MULTIPLEXED MODE	13
3.1.1	Standard Access Mode	14
3.1.2	Burst Mode	14
3.1.3	User Registers	14
3.2	MULTIPLEXED MODE	15

4.0 Direct Memory Access (DMA) Support

4.1	STANDARD DMA MODE (DMA)	16
4.2	AUTOMATIC DMA MODE (ADMA)	17

5.0 MICROWIRE/PLUS Interface

5.1	OPERATING COMMANDS	19
5.2	READ AND WRITE TIMING	20

6.0 Functional Description

6.1	FUNCTIONAL STATES	22
6.1.1	Line Condition Detection	22
6.1.2	Functional State Transition	22
6.2	ENDPOINT OPERATION	24
6.2.1	Address Detection	24
6.2.2	Transmit and Receive Endpoint FIFOs	24
6.2.3	Programming Model	28
6.3	POWER SAVING MODES	28
6.4	CLOCK GENERATION	29

7.0 Register Set

7.1	CONTROL REGISTERS	30
7.1.1	Main Control Register (MCNTRL)	30

(Continued)

7.1.2	Clock Configuration Register (CCONF).....	31
7.1.3	Revision Identifier (RID)	31
7.1.4	Node Functional State Register (NFSR)	32
7.1.5	Main Event Register (MAEV)	32
7.1.6	Main Mask Register (MAMSK)	33
7.1.7	Alternate Event Register (ALTEV).....	33
7.1.8	Alternate Mask Register (ALTMSK)	34
7.1.9	Transmit Event Register (TXEV)	34
7.1.10	Transmit Mask Register (TXMSK)	35
7.1.11	Receive Event Register (RXEV)	35
7.1.12	Receive Mask Register (RXMSK)	35
7.1.13	NAK Event Register (NAKEV)	36
7.1.14	NAK Mask Register (NAKMSK)	36
7.2	TRANSFER REGISTERS	36
7.2.1	FIFO Warning Event Register (FWEV)	36
7.2.2	FIFO Warning Mask Register (FWMSK)	37
7.2.3	Frame Number High Byte Register (FNH)	37
7.2.4	Frame Number Low Byte Register (FNL)	37
7.2.5	Function Address Register (FAR)	38
7.2.6	DMA Control Register (DMACNTRL)	38
7.2.7	DMA Event Register (DMAEV)	39
7.2.8	DMA Mask Register (DMAMSK)	40
7.2.9	Mirror Register (MIR)	41
7.2.10	DMA Count Register (DMACNT)	41
7.2.11	DMA Error Register (DMAERR)	41
7.2.12	Wake-Up Register (WKUP)	42
7.2.13	Endpoint Control 0 Register (EPC0)	43
7.2.14	Transmit Status 0 Register (TXS0)	43
7.2.15	Transmit Command 0 Register (TXC0)	44
7.2.16	Transmit Data 0 Register (TXD0)	44
7.2.17	Receive Status 0 Register (RXS0)	44
7.2.18	Receive Command 0 Register (RXC0)	45
7.2.19	Receive Data 0 Register (RXD0)	45
7.2.20	Endpoint Control X Register (EPC1 to EPC6)	46
7.2.21	Transmit Status X Register (TXS1, TXS2, TXS3)	46
7.2.22	Transmit Command X Register (TXC1, TXC2, TXC3)	47
7.2.23	Transmit Data X Register (TXD1, TXD2, TXD3)	48
7.2.24	Receive Status X Register (RXS1, RXS2, RXS3)	48
7.2.25	Receive Command X Register (RXC1, RXC2, RXC3)	49
7.2.26	Receive Data X Register (RXD1, RXD2, RXD3)	50

(Continued)

7.3 REGISTER MAP 50

8.0 Device Characteristics

8.1 ABSOLUTE MAXIMUM RATINGS 52

8.2 DC ELECTRICAL CHARACTERISTICS 52

8.3 AC ELECTRICAL CHARACTERISTICS 53

8.4 PARALLEL INTERFACE TIMING (MODE1-0 = 00B) 54

8.5 PARALLEL INTERFACE TIMING (MODE1-0 = 01B) 55

8.6 DMA SUPPORT TIMING 57

8.7 MICROWIRE INTERFACE TIMING (MODE1-0 = 10B) 58

1.0 Signal/Pin Connection and Description

1.1 CONNECTION DIAGRAMS

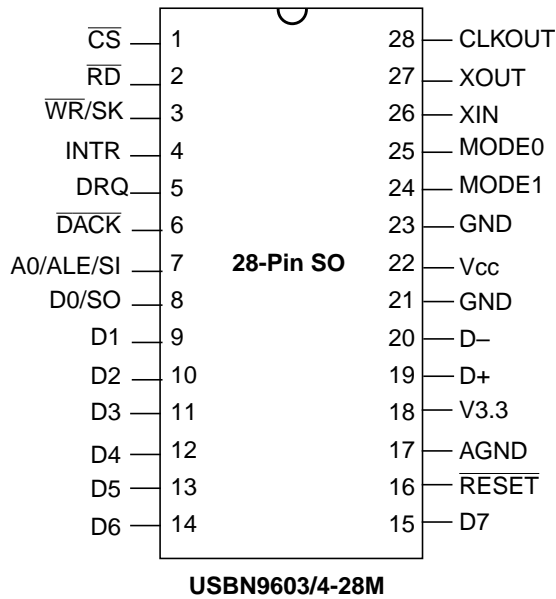
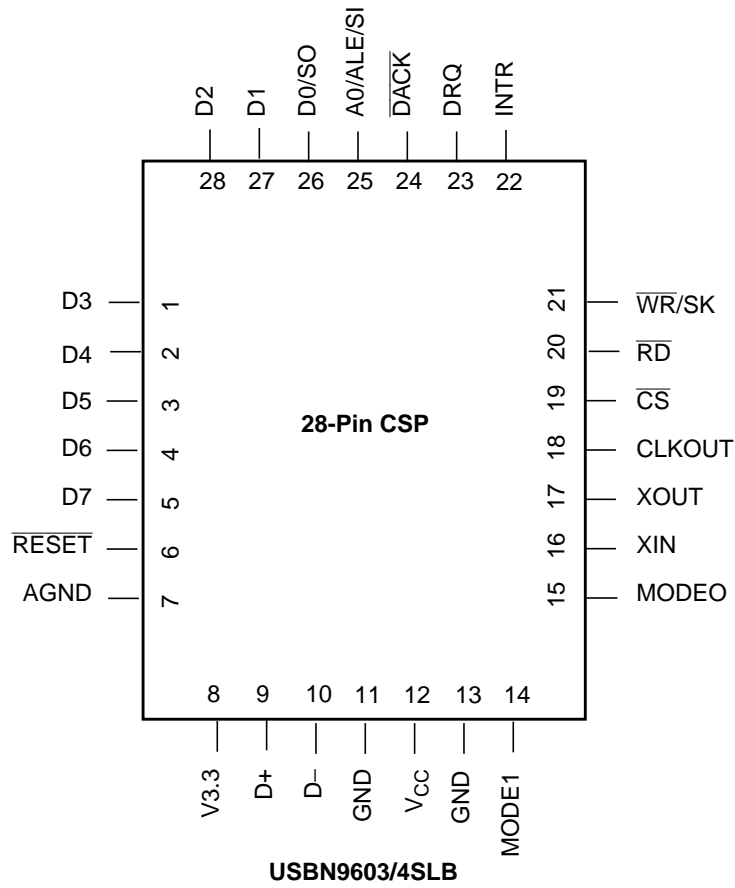

1.0 Signal/Pin Connection and Description (Continued)

1.2 DETAILED SIGNAL/PIN DESCRIPTIONS

1.2.1 Power Supply

I/O	Name	Description
NA	V _{CC}	Digital Power Supply (V_{CC}). Power-on reset is detected when the input voltage is at the same level as GND and then raised to the required V _{CC} level. The power-on reset causes all registers to be set to their reset values, the clock generator to be reset and stalls the CLKOUT output for 2 ¹⁴ XIN clock cycles. During this time, no internal register is accessible.
NA	GND	Digital Power Supply (GND)
NA	AGND	Analog Power Supply (AGND)
NA	V3.3	Transceiver 3.3V Voltage Supply. This pin can be used as the internal 3.3V voltage regulator output. The regulator is intended to power only the internal transceiver and one external pull-up. An external 1 μF de-coupling capacitor is required on this pin. The voltage regulator output is disabled upon reset. When the internal voltage regulator is left disabled, this pin must be used as a 3.3V supply input for the internal transceiver. This is the case during 3.3V operation.

1.2.2 Oscillator, Clock and Reset

I/O	Name	Description
NA	XIN	Crystal Oscillator Input. Input for internal 24 MHz crystal oscillator circuit. A 24 MHz fundamental crystal may be used.
NA	XOUT	Crystal Oscillator Output
O	CLKOUT	Clock Output. This programmable clock output may be disabled and configured for different speeds via the Clock Configuration register. After a power-on reset and hardware reset (assertion of RESET), a 4 MHz clock signal is output (there may be an initial phase discontinuity). In the USBN9604, a hardware reset causes CLKOUT to stall for 2 ¹⁴ XIN clock cycles while the internal DLL is synchronized to the external reference clock.
I	RESET	Reset. Active low, assertion of RESET indicates a hardware reset, which causes all registers in the device to revert to their reset values. In the USBN9604, the hardware reset action is identical to a power-on reset. Signal conditioning is provided on this input to allow use of a simple, RC power-on reset circuit.

Oscillator Circuit

The XIN and XOUT pins may be connected to make a 24 MHz closed-loop, crystal-controlled oscillator. Alternately, an external 24 MHz clock source may be used as the input clock for the device. The internal crystal oscillator uses a 24 MHz fundamental crystal. See Table 1 for typical component values and Figure 1 for the crystal circuit. For a specific crystal, please consult the manufacturer for recommended component values.

If an external clock source is used, it is connected to XIN. XOUT should remain unconnected. Stray capacitance and inductance should be kept as low as possible in the oscillator circuit. Trace lengths should be minimized by positioning the crystal and external components as close as possible to the XIN and XOUT pins.

Table 1. Approximate Component Values

Component	Parameters	Values	Tolerance
Crystal Resonator	Resonance Frequency	24 MHz	2500 ppm (max)
	Type	AT-Cut	
	Maximum Serial Resistance	50 Ω	
	Maximum Shunt Capacitance	10 pF	
	Load Capacitance	20 pF	
Resistor R1		1 MΩ	±5%

1.0 Signal/Pin Connection and Description (Continued)

Component	Parameters	Values	Tolerance
Resistor R2		0	NA
Capacitor C1		15 pF	±20%
Capacitor C2		15 pF	±20%

External Elements

Choose C1 and C2 capacitors (see Figure 1) to match the crystal's load capacitance. The load capacitance C_L "seen" by the crystal is comprised of C1 in series with C2, and in parallel with the parasitic capacitance of the circuit. The parasitic capacitance is caused by the chip package, board layout and socket (if any), and can vary from 0 to 8 pF. The rule of thumb in choosing these capacitors is:

$$C_L = (C1 * C2) / (C1 + C2) + C_{\text{Parasitic}}$$

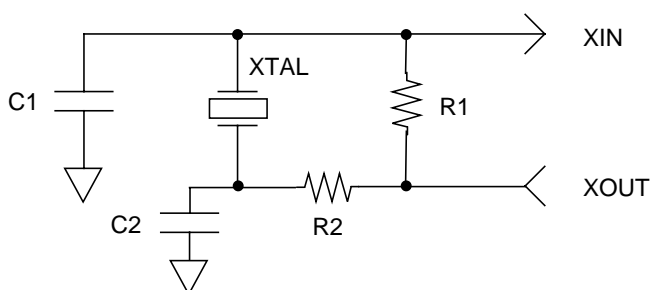

Figure 1. Typical Oscillator Circuit

1.2.3 USB Port

I/O	Name	Description
I/O	D+	USB D+ Upstream Port. This pin requires an external 1.5k pull-up to 3.3V to signal full speed operation.
I/O	D-	USB D- Upstream Port

1.2.4 Microprocessor Interface

I/O	Name	Description
I	MODE1-0	Interface Mode. Each of these pins should be hard-wired to V_{CC} or GND to select the interface mode: MODE1-0 = 00. Mode 0: Non-multiplexed parallel interface mode MODE1-0 = 01. Mode 1: Multiplexed parallel interface mode MODE1-0 = 10. Mode 2: MICROWIRE interface mode MODE1-0 = 11. Mode 3: Reserved Note: Mode 3 also selects the MICROWIRE interface mode in the USBN9602, but this mode should be reserved to preserve compatibility with future devices.
I	\overline{DACK}	DMA Acknowledge. This active low signal is only used if DMA is enabled. If DMA is not used, this pin must be tied to V_{CC} .
O	DRQ	DMA Request. This pin is used for DMA request only if DMA is enabled.
O	INTR	Interrupt. The interrupt signal modes (active high, active low or open drain) can be configured via the Main Control register. During reset, this signal is TRI-STATE.
I	\overline{CS}	Chip Select. Active low chip select
I	\overline{RD}	Read. Active low read strobe, parallel interface

1.0 Signal/Pin Connection and Description (Continued)

I	\overline{WR}	Write. Active low write strobe, parallel interface
	SK	MICROWIRE Shift Clock. Mode 2
I	A0	A0 Address Bus Line. Mode 0, parallel interface
	ALE	Address Latch Enable. Mode 1, parallel interface
	SI	MICROWIRE Serial Input. Mode 2
I/O	D0	Data Bus Line D0. Mode 0
	AD0	Address/Data Bus Line AD0. Mode 1
	SO	MICROWIRE Serial Output. Mode 2
I/O	D1	Data Bus Line D1. Mode 0
	AD1	Address/Data Bus Line AD1. Mode 1
I/O	D2	Data Bus Line D2. Mode 0
	AD2	Address/Data Bus Line AD2. Mode 1
I/O	D3	Data Bus Line D3. Mode 0
	AD3	Address/Data Bus Line AD3. Mode 1
I/O	D4	Data Bus Line D4. Mode 0
	AD4	Address/Data Bus Line AD4. Mode 1
I/O	D5	Data Bus Line D5. Mode 0
	AD5	Address/Data Bus Line AD5. Mode 1
I/O	D6	Data Bus Line D6. Mode 0
	AD6	Address/Data Bus Line AD6. Mode 1
I/O	D7	Data Bus Line D7. Mode 0
	AD7	Address/Data Bus Line AD7. Mode 1

2.0 Functional Overview

The device is a Universal Serial Bus (USB) Node controller compatible with USB Specification, 1.0 and 1.1. It integrates onto a single IC the required USB transceiver with a 3.3V regulator, the Serial Interface Engine (SIE), USB endpoint FIFOs, a versatile (8-bit parallel or serial) interface and a clock generator. A total of seven endpoint pipes are supported: one bidirectional for the mandatory control EP0 and an additional six for unidirectional endpoints to support USB interrupt, bulk and isochronous data transfers. The 8-bit parallel interface supports multiplexed and non-multiplexed style CPU address/data buses. The synchronous serial MICROWIRE interface allows adapting to CPUs without external address/data buses. A programmable interrupt output scheme allows adapting to different interrupt signaling requirements.

Refer to Figure 2 for the major functional blocks, described in the following sections.

2.1 TRANSCEIVER

The device contains a high-speed transceiver which consists of three main functional blocks:

- Differential receiver
- Single-ended receiver with on-chip voltage reference
- Transmitter with on-chip current source.

This transceiver meets the performance requirements described in Chapter 7 of the USB Specification, Version 1.1.

To minimize signal skew, the differential output swings of the transmitter are well balanced. Slew-rate control is used on the driver to minimize radiated noise and crosstalk. The drivers support TRI-STATE operation to allow bidirectional, half-duplex operation of the transceiver.

The differential receiver operates over the complete common mode range, and has a delay guaranteed to be larger than that of the single-ended receivers. This avoids potential glitches in the Serial Interface Engine (SIE) after single-ended zeros.

Single-ended receivers are present on each of the two data lines. These are required, in addition to the differential receiver, to detect an absolute voltage with a switching threshold between 0.8V and 2.0V (TTL inputs). To increase V_{CC} rejection, without glitching, a voltage reference sets the single-ended switching reference. An external $1.5 \pm 5\%$ K Ω resistor is required on D+ to indicate that this is a high-speed node. This resistor should be tied to a voltage source between 3.0V and 3.6V, and referenced to the local ground, such as the output provided on pin V3.3.

2.2 VOLTAGE REGULATOR (VREG)

The voltage regulator provides 3.3V for the integrated transceiver from 5.0V device power or USB bus power. This output can be used to supply power to the 1.5 K Ω pull-up resistor. This output must be decoupled with a 1 μ F tantalum capacitor to ground. It can be disabled under software control to allow using the device in a 3.3V system.

2.3 SERIAL INTERFACE ENGINE (SIE)

The SIE is comprised of physical (PHY) and Media Access Controller (MAC) modules. The PHY module includes the digital-clock recovery circuit, a digital glitch filter, End Of Packet (EOP) detection circuitry, and bit stuffing and unstuffing logic. The MAC module includes packet formatting, CRC generation and checking, and endpoint address detection. It provides the necessary control to give the NAK, ACK and STALL responses as determined by the Endpoint Pipe Controller (EPC) for the specified endpoint pipe. The SIE is also responsible for detecting and reporting USB-specific events, such as NodeReset, NodeSuspend and NodeResume. The module output signals to the transceiver are well matched (under 1 nS) to minimize skew on the USB signals.

The USB specifications assign bit stuffing and unstuffing as the method to ensure adequate electrical transitions on the line to enable clock recovery at the receiving end. The bit stuffing block ensures that whenever a string of consecutive 1's is encountered, a 0 is inserted after every sixth 1 in the data stream. The bit unstuffing logic reverses this process.

The clock recovery block uses the incoming NRZI data to extract a data clock (12 MHz) from a 48 MHz input clock. This input clock is derived from a 24 MHz oscillator in conjunction with PLL circuitry (clock doubler). This clock is used in the data recovery circuit. The output of this block is binary data (decoded from the NRZI stream) which can be appropriately sampled using the extracted 12 MHz clock. The jitter performance and timing characteristics meet the requirements set forth in Chapter 7 of the USB Specification.

2.0 Functional Overview (Continued)

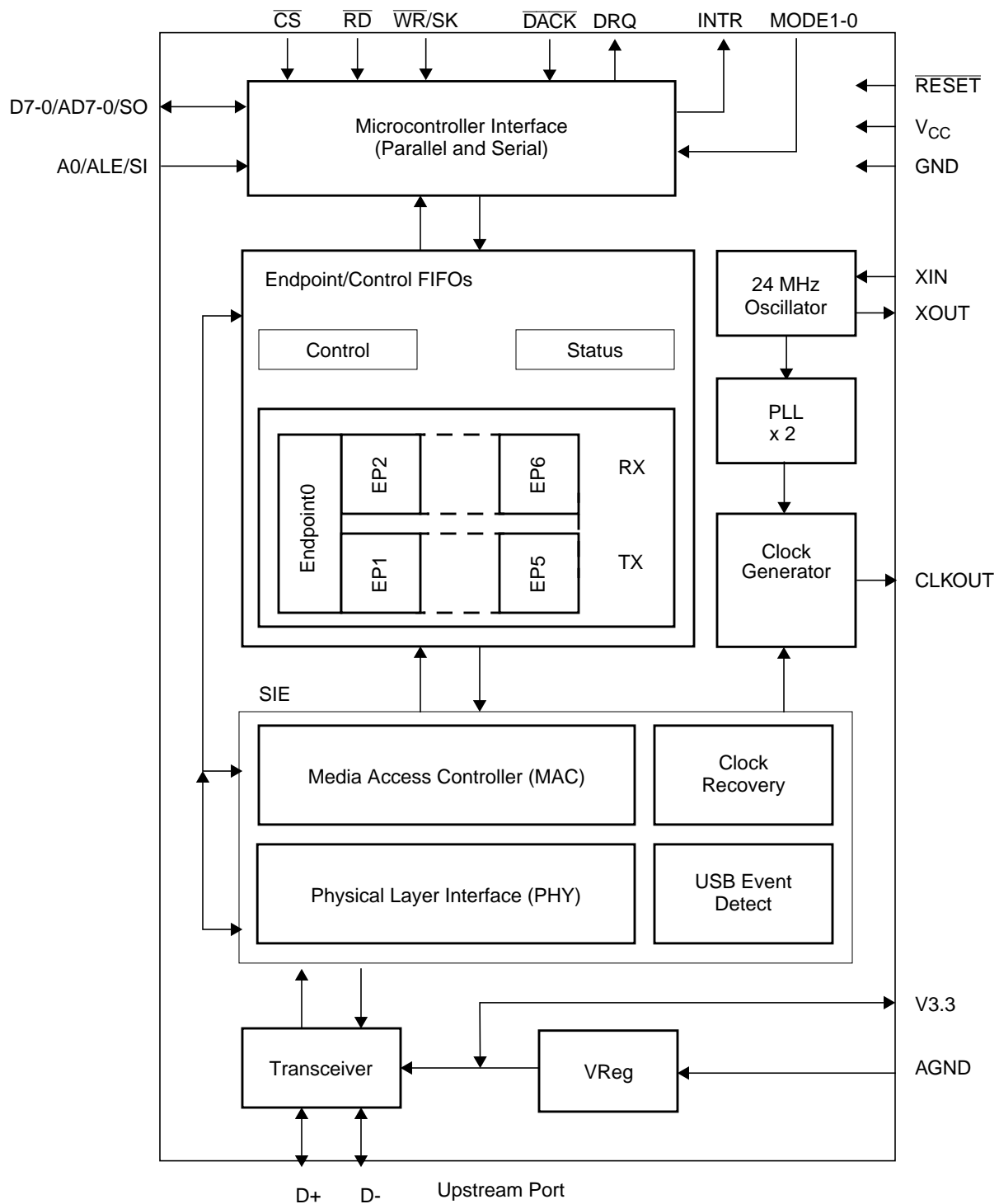

Figure 2. USBN9603/4 Block Diagram

2.0 Functional Overview (Continued)

2.4 ENDPOINT PIPE CONTROLLER (EPC)

The EPC provides the interface for USB function endpoints. An endpoint is the ultimate source or sink of data. An endpoint pipe facilitates the movement of data between USB and memory, and completes the path between the USB host and the function endpoint. According to the USB specification, up to 31 such endpoints are supported at any given time. USB allows a total of 16 unidirectional endpoints for receive and 16 for transmit. As the control endpoint 0 is always bidirectional, the total number is 31. Seven endpoint pipes with the same function address are supported. See Figure 3 for a schematic diagram of EPC operation.

A USB function is a USB device that is able to transmit and receive information on the bus. A function may have one or more configurations, each of which defines the interfaces that make up the device. Each interface, in turn, is composed of one or more endpoints.

Each endpoint is an addressable entity on USB and is required to respond to IN and OUT tokens from the USB host (typically a PC). IN tokens indicate that the host has requested to receive information from an endpoint, and OUT tokens indicate that it is about to send information to an endpoint.

On detection of an IN token addressed to an endpoint, the endpoint pipe should respond with a data packet. If the endpoint pipe is currently stalled, a STALL handshake packet is sent under software control. If the endpoint pipe is enabled but no data is present, a NAK (Negative Acknowledgment) handshake packet is sent automatically. If the endpoint pipe is isochronous and enabled but no data is present, a bit stuff error followed by an end of packet is sent on the bus.

Similarly, on detection of an OUT token addressed to an endpoint, the endpoint pipe should receive a data packet sent by the host and load it into the appropriate FIFO. If the endpoint pipe is stalled, a STALL handshake packet is sent. If the endpoint pipe is enabled but no buffer is present for data storage, a NAK handshake packet is sent. If the endpoint is isochronous and enabled but cannot handle the data, no handshake packet is sent.

A disabled endpoint does not respond to IN, OUT, or SETUP tokens.

The EPC maintains separate status and control information for each endpoint pipe.

For IN tokens, the EPC transfers data from the associated FIFO to the host. For OUT tokens, the EPC transfers data in the opposite direction.

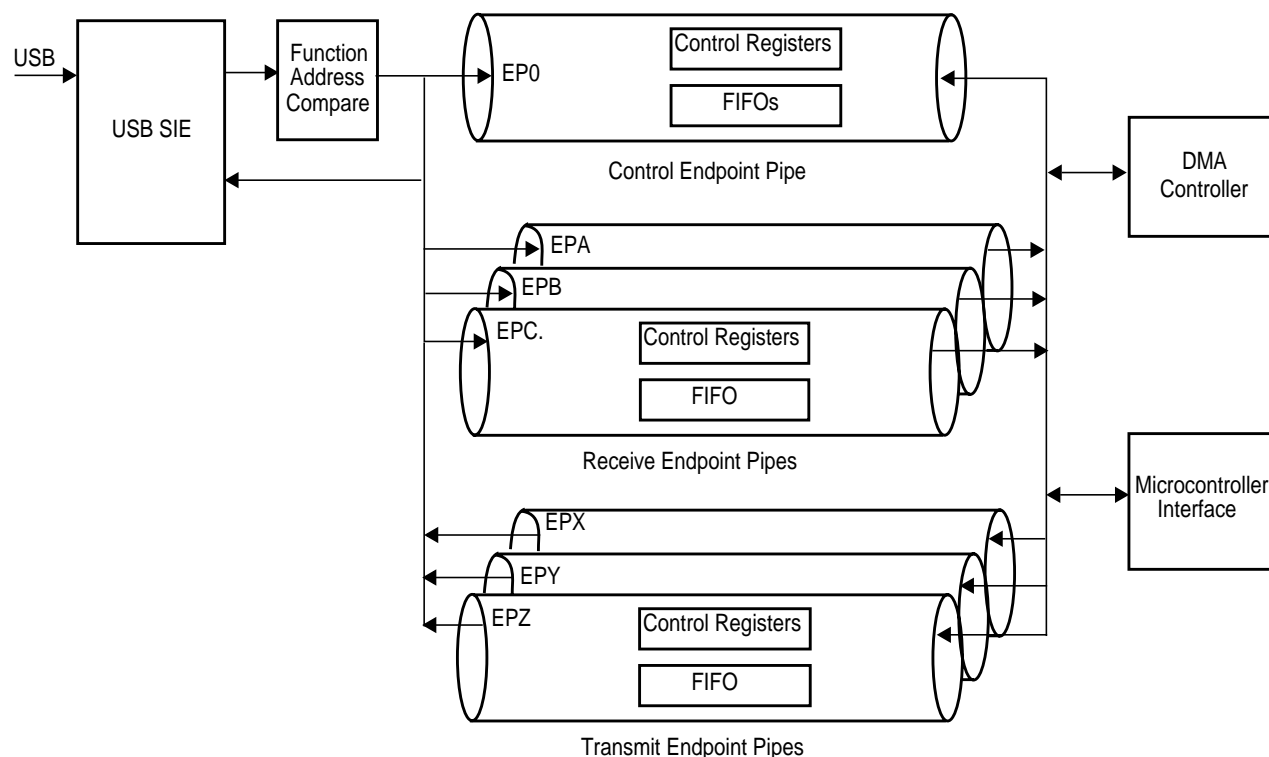

Figure 3. EPC Operation

2.5 MICROCONTROLLER INTERFACE

The device can be connected to a CPU or microcontroller via the 8-bit parallel or MICROWIRE interface. The interface type is selected by the input mode pins MODE0 and MODE1. In addition, a configurable interrupt output is provided. The interrupt type can be configured to be either open-drain active-low or push-pull active high or low.

3.0 Parallel Interface

The parallel interface allows the device to function as a CPU or microcontroller peripheral. This interface type and its addressing mode (multiplexed or non-multiplexed) is determined via device input pins MODE0 and MODE1.

3.1 NON-MULTIPLEXED MODE

Non-multiplexed mode uses the control pins \overline{CS} , \overline{RD} , \overline{WR} , the address pin A0 and the bidirectional data bus D7-0 as shown in Figure 4. This mode is selected by tying both the MODE1 and MODE0 pins to GND.

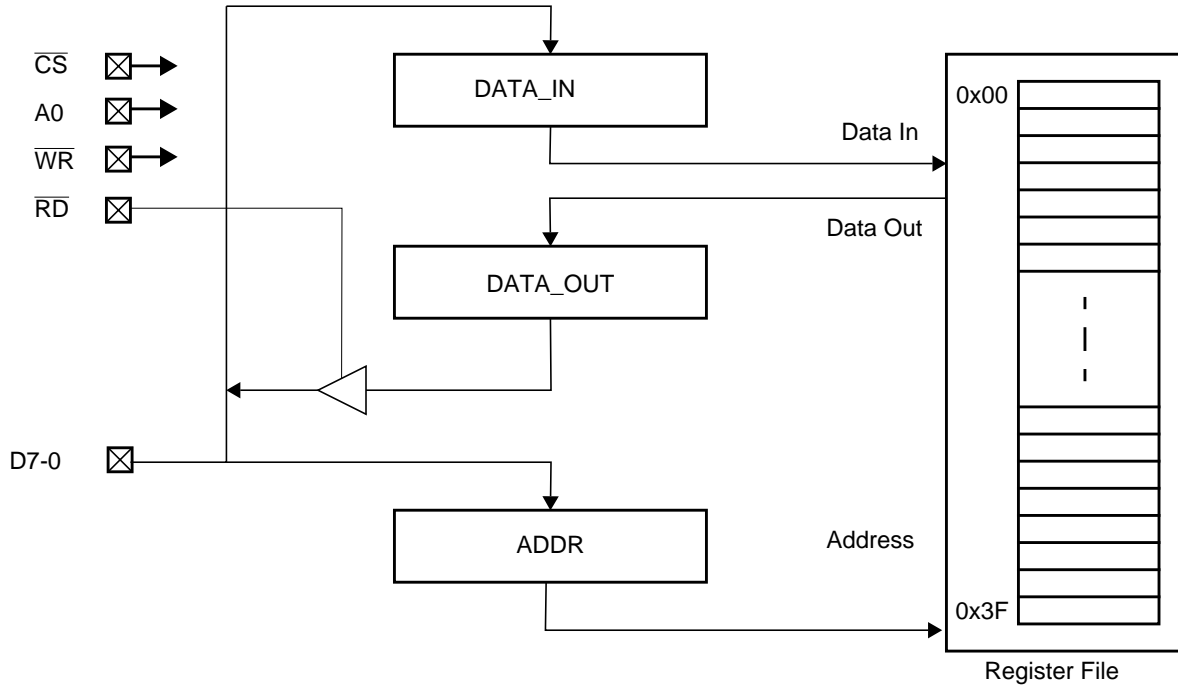

Figure 4. Non-Multiplexed Mode Block Diagram

The CPU has direct access to the DATA_IN, DATA_OUT and ADDR registers. Reading and writing data to the device can be done either in standard access or burst mode. See Figure 5 for timing information.

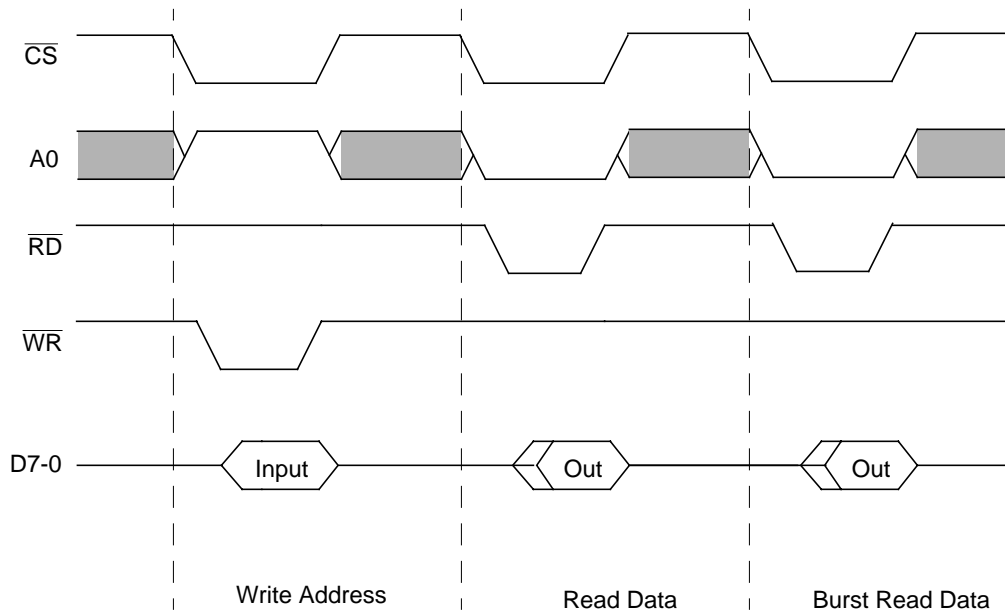

Figure 5. Non-Multiplexed Mode Timing Diagram

3.0 Parallel Interface (Continued)

3.1.1 Standard Access Mode

The standard access sequence for non-multiplexed mode is to write the address to the ADDR register and then read or write the data from/to the DATA_OUT/DATA_IN register. The DATA_OUT register is updated after writing to the ADDR register. The ADDR register or the DATA_OUT/DATA_IN register is selected with the A0 input.

3.1.2 Burst Mode

In burst mode, the ADDR register is written once with the desired memory address of any of the on-chip registers. Then consecutive reads/writes are performed to the DATA_IN/DATA_OUT register without previously writing a new address. The content of the DATA_OUT register for read operations is updated once after every read or write.

3.1.3 User Registers

The following table gives an overview of the parallel interface registers in non-multiplexed mode.

The reserved bits return undefined data on read and should be written with 0.

A0	Access	bit 7	bit 6	bit 5	bit 4	bit 3	bit 2	bit 1	bit 0
0	Read	DATA_OUT							
0	Write	DATA_IN							
1	Read	Reserved							
1	Write	Reserved		ADDR5-0					

Address Register (ADDR)

The ADDR register acts as a pointer to the internal memory. This register is write only and is cleared on reset.

Data Output Register (DATA_OUT)

The DATA_OUT register is updated with the contents of the memory register to which the ADDR register is pointing. Update occurs under the following conditions:

1. After the ADDR register is written.
2. After a read from the DATA_OUT register.
3. After a write to the DATA_IN register.

This register is read only and holds undefined data after reset.

Data Input Register (DATA_IN)

The DATA_IN register holds the data written to the device address to which ADDR points. This register is write only and is cleared on reset.

3.0 Parallel Interface (Continued)

3.2 MULTIPLEXED MODE

Multiplexed mode uses the control pins \overline{CS} , \overline{RD} , \overline{WR} , the address latch enable signal ALE and the bidirectional address data bus AD7-0 as shown in Figure 6. This mode is selected by tying MODE1 to GND and MODE0 to V_{CC} . The address is latched into the ADDR register when ALE is high. Data is output/input with the next active \overline{RD} or \overline{WR} signal. All registers are directly accessible in this interface mode.

Figure 7 shows basic timing of the interface in Multiplexed mode.

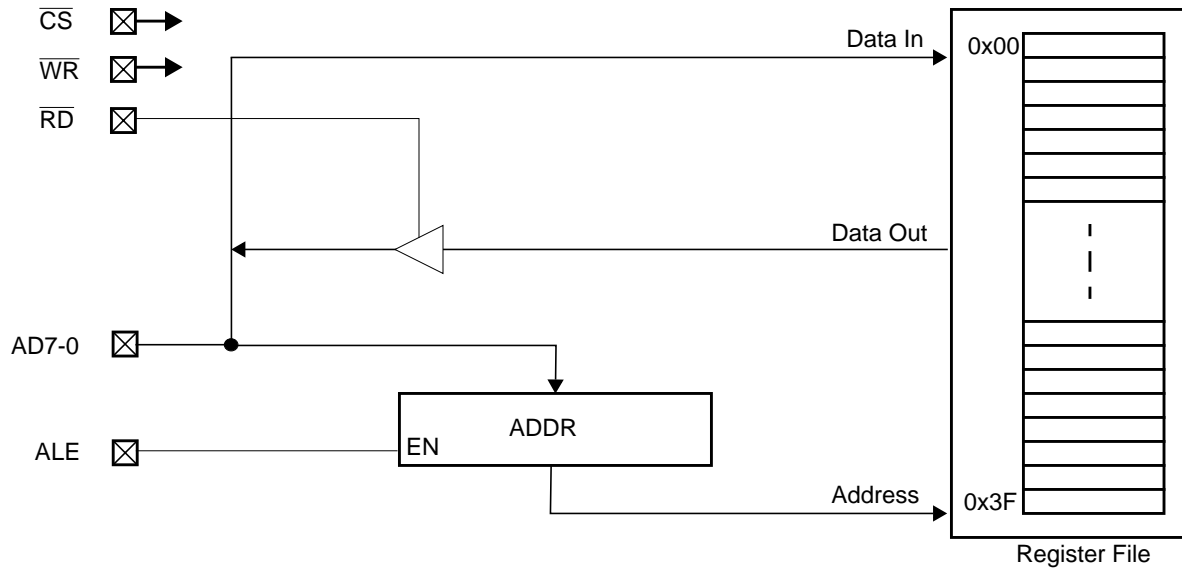

Figure 6. Multiplexed Mode Block Diagram

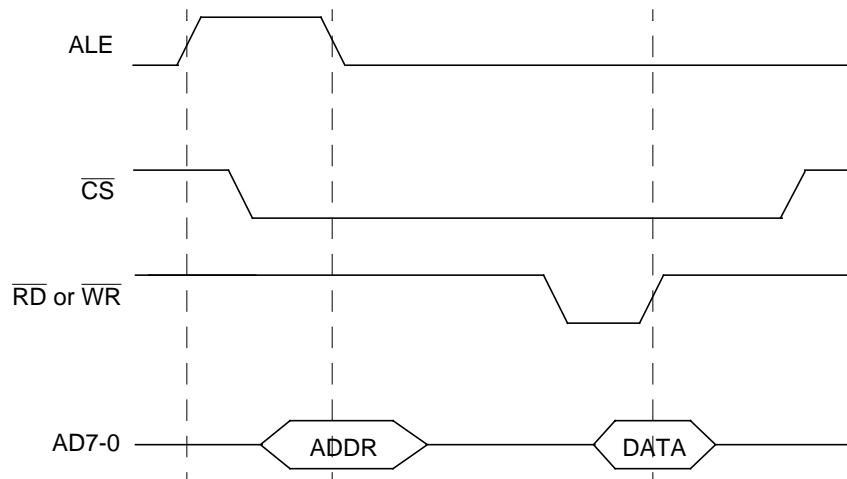

Figure 7. Multiplexed Mode Basic Read/Write Timing

4.0 Direct Memory Access (DMA) Support

The device supports DMA transfers with an external DMA controller from/to endpoints 1 to 6. This mode uses the device pins DRQ and \overline{DACK} in addition to the parallel interface pins \overline{RD} or \overline{WR} and D7-0 data pins. DMA mode can only be used with parallel interface mode (MODE1 must be grounded). The read or write address is generated internally and the state of the A0/ALE pin is ignored during a DMA cycle.

The DMA support logic has a lower priority than the parallel interface. \overline{CS} must stay inactive during a DMA cycle. If \overline{CS} becomes active, \overline{DACK} is ignored and a regular read/write operation is performed. Only one endpoint can be enabled at any given time to issue a DMA request when data is received or transmitted.

Two different DMA modes are supported: standard and automatic.

4.1 STANDARD DMA MODE (DMA)

To enable DMA transfers in standard DMA mode, the following steps must be performed:

1. The local CPU programs the DMA controller for fly-by demand mode transfers. In this mode, transfers occur only when the device requests them via the DRQ pin. The data is read/written from/to the device receive/transmit FIFO and written/read into/from local memory during the same bus transaction.
2. The DMA address counter is programmed to point to the destination memory block in the local shared memory, and the Byte Count register is programmed with the number of bytes in the block to be transferred. If required the automatic error handling should be enabled at this point along with the error handling counter. In addition the user needs to set the respective Endpoint enable bit.
3. The DMA Enable bit and DMA Source bits are set in the DMACNTRL register.
4. The USB host can now perform USB bulk or isochronous data transfers over the USB bus to the receive FIFO or from the transmit FIFO in the device.
5. If the FIFOs warning limit is reached or the transmission/reception is completed, a DMA request/acknowledge sequence is initiated for the predetermined number of bytes. The time at which a DMA request is issued depends on the selected DMA mode (controlled by the DMOD bit in the DMACNTRL register), the current status of the endpoint FIFO, and the FIFO warning enable bits. A DMA request can be issued immediately.
6. After the DMA controller has granted control of the bus, it drives a valid memory address and asserts \overline{DACK} and \overline{RD} or \overline{WR} , thus transferring a byte from the receive FIFO to memory, or from memory to the transmit FIFO. This process continues until the DMA byte count, within the DMA controller, reaches zero.
7. After the programmed amount of data is transferred, the firmware must do one of the following (depending on the transfer direction and mode):
 - Queue the new data for transmission by setting the TX_EN bit in the TXCx register.
 - Set the End Of Packet marker by setting the TX_LAST bit in the TXCx register. Re-enable reception by setting the RX_EN bit in the RXCx register.
 - Check if the last byte of the packet was received (RX_LAST bit in the RXSx register).

The DMA transfer can be halted at any time by resetting the DMA Request Enable bit. If the DMA Request Enable bit is cleared during the middle of a DMA cycle, the current cycle is completed before the DMA request is terminated.

See Figures 8 and 9 for the transmit and receive sequences using standard DMA mode.

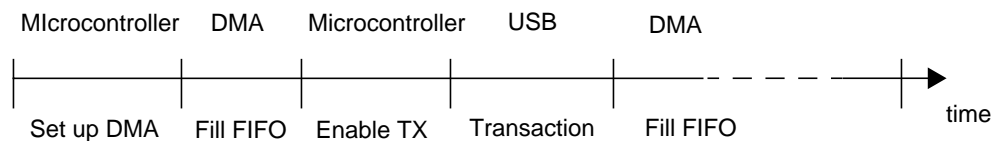

Figure 8. Transmit Operation in Standard DMA Mode

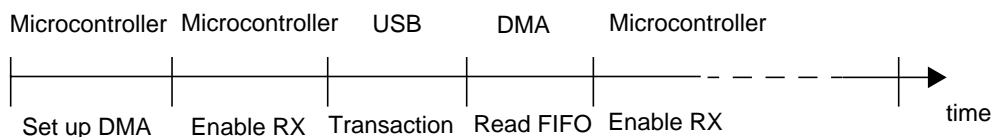

Figure 9. Receive Operation in Standard DMA Mode

4.0 Direct Memory Access (DMA) Support (Continued)

4.2 AUTOMATIC DMA MODE (ADMA)

The ADMA mode allows the CPU to transfer independently large bulk or isochronous data streams to or from the USB bus. The application's DMA controller, together with the ADMA logic, have the capability to split a large amount of data and transfer it in (FIFO size) packets via the USB. In addition, automatic error handling is performed in order to minimize firmware intervention. The number of transferred data stream bytes must be of a modulo 64 size. The maximum amount of data is restricted to 256×64 bytes = 16 Kbytes.

To enable an ADMA transfer, the following steps must be performed:

1. The local CPU programs the DMA controller for fly-by demand mode transfers. In this mode, transfers occur only in response to DMA request via the DRQ pin. The data is read/written from/to the receive/transmit FIFO and written/read into/from local memory during the same bus transaction.
2. The DMA address counter is programmed to point to the destination memory block in the local shared memory, and the Byte Count register is programmed with the number of bytes in the block to be transferred. The DMA Count register must be configured with the number of packets to be received or transmitted. If required, the Automatic Error Handling register must also be configured at this time.
3. The ADMA enable bit must be set prior to, or at the same time as the DMA enable bit. The DMA enable bit must be cleared before enabling ADMA mode.
4. The DMA Request Enable bit and DMA Source bits are set in the device. The respective endpoint Enable bit must also be set.
5. The USB host can now perform USB bulk or isochronous data transfers over the USB bus to the receive FIFO or from the transmit FIFO. Steps 5 to 7 of the normal DMA mode are performed automatically. The ADMA is stopped either when the last packet is received or when the DMA Count register has reached the value zero.

See Figures 10 and 11 for the transmit and receive sequences using ADMA mode. See Figures 12 and 13 for the basic DMA write timing and read timing.

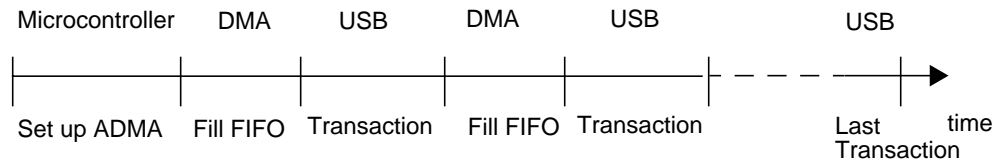

Figure 10. Transmit Operation Using ADMA Mode

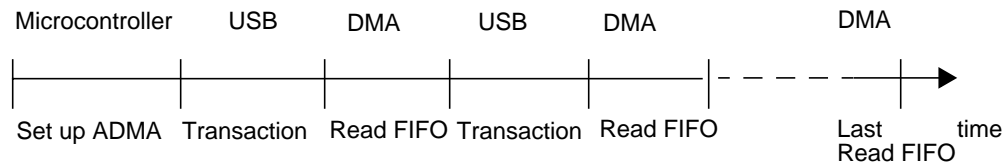

Figure 11. Receive Operation Using ADMA Mode

4.0 Direct Memory Access (DMA) Support (Continued)

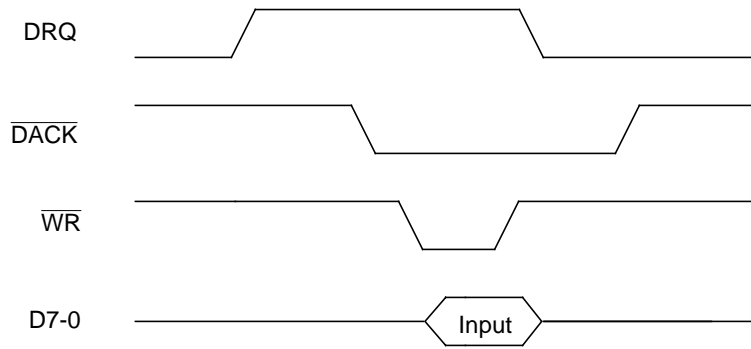

Figure 12. DMA Write to USBN9603/4

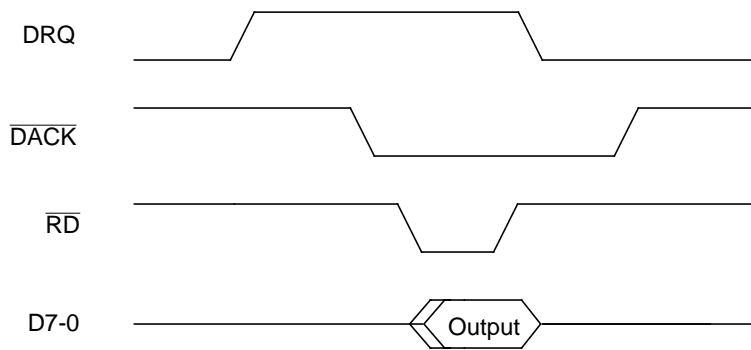

Figure 13. DMA Read from USBN9603/4

5.0 MICROWIRE/PLUS Interface

The MICROWIRE/PLUS interface allows the device to function as a CPU or microcontroller peripheral via a serial interface. This mode is selected by pulling the MODE1 pin high and the MODE0 pin low. The MICROWIRE/PLUS mode uses the chip select (\overline{CS}), serial clock (SK), serial data in (SI) and serial data out (SO) pins, as shown in Figure 14.

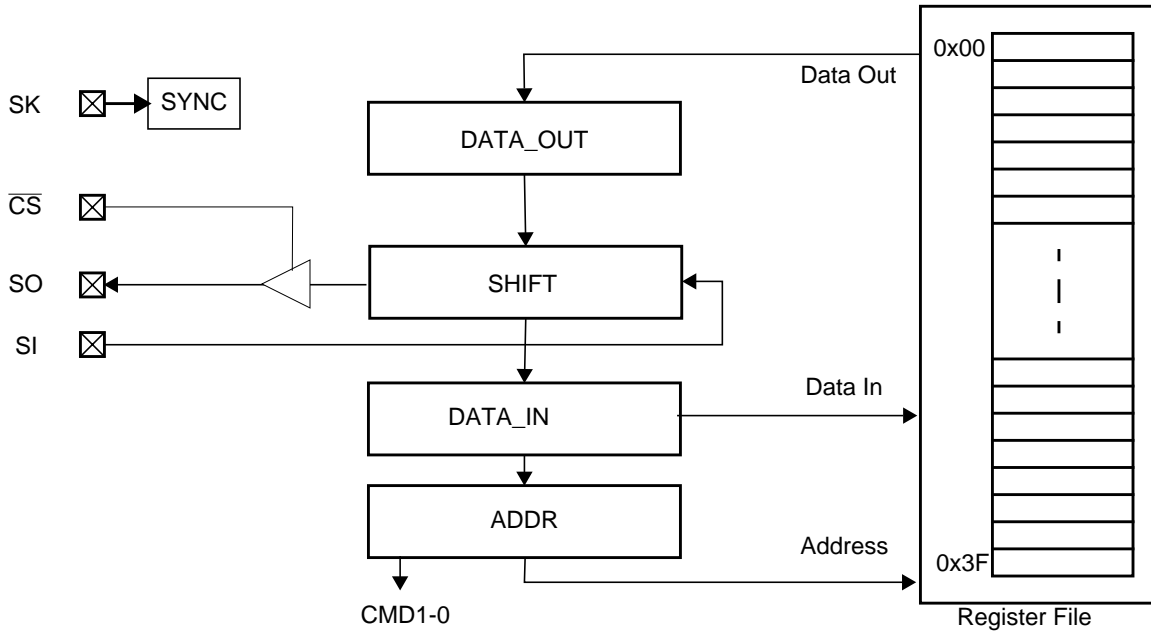

Figure 14. MICROWIRE/PLUS Interface Block Diagram

5.1 OPERATING COMMANDS

The MICROWIRE/PLUS interface is enabled by a falling edge of \overline{CS} and reset with a rising edge of \overline{CS} . Data on SI is shifted in after the rising edge of SK. Data is shifted out on SO after the falling edge of SK. Data is transferred from/to the Shift register after the falling edge of the eighth SK clock. Data is transferred with the most significant bit first. Table 2 summarizes the available commands (CMD) for the MICROWIRE/PLUS interface.

Note: A write operation to any register always reads the contents of the register after the write has occurred, and shifts out that data in the next cycle. This read does not clear the bit in the respective registers, even for a Clear on Read (CoR) type bit, with one exception: writing to the TXDx (transmit data) registers, which causes undefined data to be read during the next cycle.

Table 2. Command/Address Byte Format

Byte Transferred		Sequence Initiated ¹					
CMD	ADDR	Cycle	Description				
				1	0	5	4
0	0	RADDR (read)	1 Shift in CMD/RADDR; shift out previous read data 2 Shift in next CMD/ADDR; shift out RADDR data				
0	1	x	1 no action; shift out previous read data (do not clear CoR bits)				
1	0	WADDR (normal write)	1 Shift in CMD/WADDR; shift out previous read data 2 Shift in WADDR write data; shift out WADDR read data (do not clear CoR bits)				
1	1	WADDR (burst write)	1 Shift in CMD/WADDR; shift out previous read data 2-n Shift in WADDR write data; shift out WADDR read data (do not clear CoR bits); terminate this mode by pulling \overline{CS} high				

1. 1 cycle = 8 SK clocks. Data is transferred after the 8th SK of 1 cycle.

5.0 MICROWIRE/PLUS Interface (Continued)

5.2 READ AND WRITE TIMING

Data is read by shifting in the 2-bit command (CMD and the 6-bit address, RADDR or WADDR) while simultaneously shifting out read data from the previous address.

Data can be written in standard or burst mode. Standard mode requires two bytes: one byte for the command and address to be shifted in, and one byte for data to be shifted in. In burst mode, the command and address are transferred first, and then consecutive data is written to that address. Burst mode is terminated when \overline{CS} becomes inactive (high).

See Figure 15 for basic read timing, Figure 16 for standard write timing, and Figure 17 for write timing in burst mode.

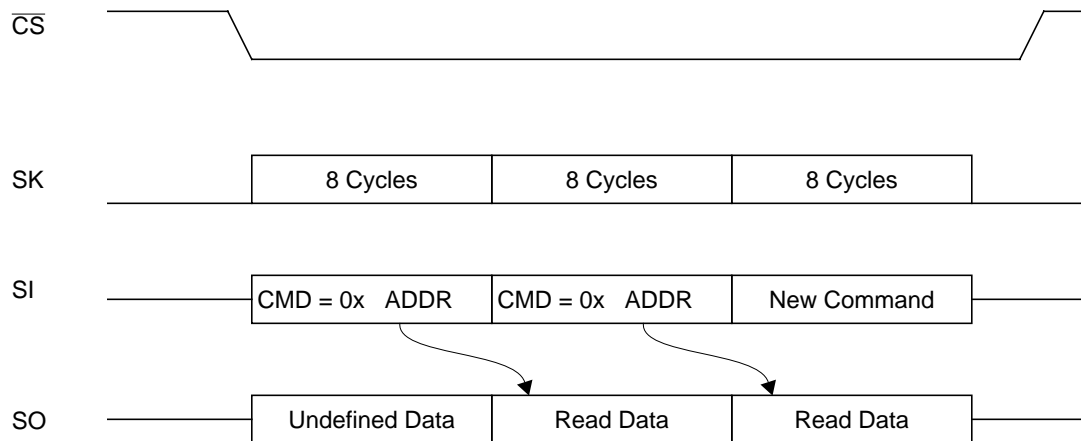

Figure 15. Basic Read Timing

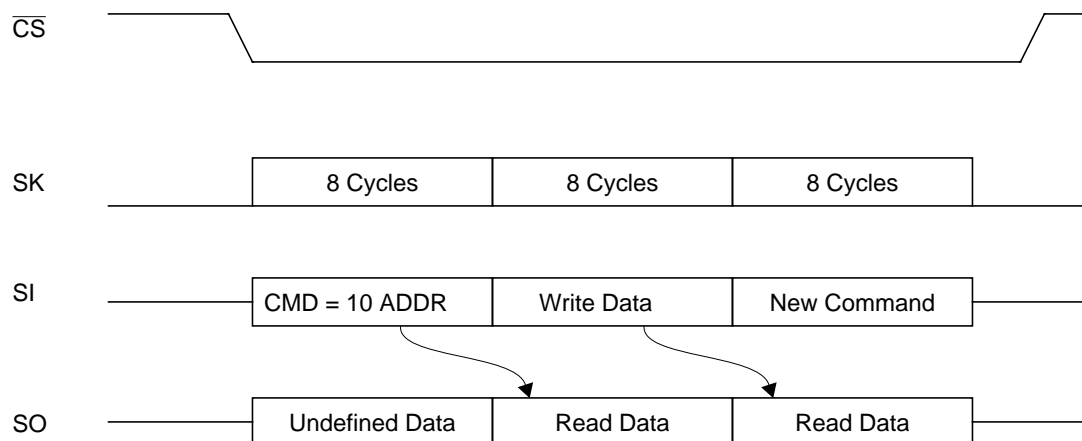

Figure 16. Standard Write Timing

5.0 MICROWIRE/PLUS Interface (Continued)

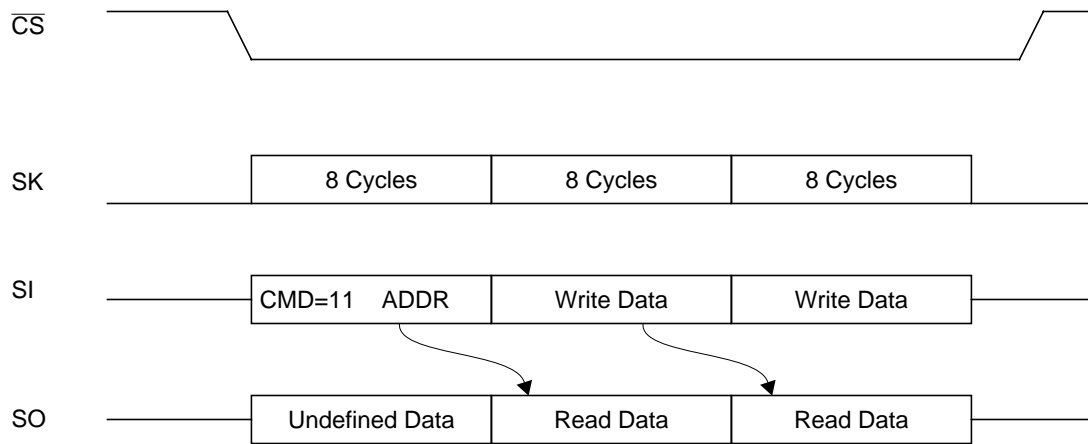

Figure 17. Burst Write Timing

6.0 Functional Description

6.1 FUNCTIONAL STATES

6.1.1 Line Condition Detection

At any given time, the device is in one of the following states (see Section 6.1.2 for the functional state transitions):

- **NodeOperational** Normal operation
- **NodeSuspend** Device operation suspended due to USB inactivity
- **NodeResume** Device wake-up from suspended state
- **NodeReset** Device reset

The **NodeSuspend**, **NodeResume**, or **NodeReset** line condition causes a transition from one operating state to another. These conditions are detected by specialized hardware and reported via the Alternate Event (ALTEV) register. If interrupts are enabled, an interrupt is generated upon the occurrence of any of the specified conditions.

NodeOperational

This is the normal operating state of the device. In this state, the node is configured for operation on the USB bus.

NodeSuspend

A USB device is expected to enter **NodeSuspend** state when 3 mS have elapsed without any detectable bus activity. The device looks for this event and signals it by setting the SD3 bit in the ALTEV register, which causes an interrupt, if enabled, to be generated. The firmware should respond by putting the device into the **NodeSuspend** state.

The device can resume normal operation under firmware control in response to a local event at the host controller. It can wake up the USB bus via a **NodeResume**, or when detecting a resume command on the USB bus, which signals an interrupt to the host controller.

NodeResume

If the host has enabled remote wake-ups from the node, the device can initiate a remote wake-up.

Once the firmware detects the event, which wakes up the bus, it releases the device from **NodeSuspend** state by initiating a **NodeResume** on the USB using the NFSR register. The node firmware must ensure at least 5 mS of Idle on the USB. While in **NodeResume** state, a constant "K" is signalled on the USB. This should last for at least 1 mS and no more than 5 mS, after which the USB host should continue sending the **NodeResume** signal for at least an additional 20 mS, and then completes the **NodeResume** operation by issuing the End Of Packet (EOP) sequence.

To successfully detect the EOP, the firmware must enter USB **NodeOperational** state by setting the NFSR register.

If no EOP is received from the host within 100 mS, the software must reinitiate **NodeResume**.

NodeReset

When detecting a **NodeResume** or **NodeReset** signal while in **NodeSuspend** state, the device can signal this to the main controller by generating an interrupt.

USB specifications require that a device must be ready to respond to USB tokens within 10 mS after wake-up or reset.

6.1.2 Functional State Transition

Figure 18 shows the device states and transitions, as well as the conditions that trigger each transition. All state transitions are initiated by the firmware.

6.0 Functional Description (Continued)

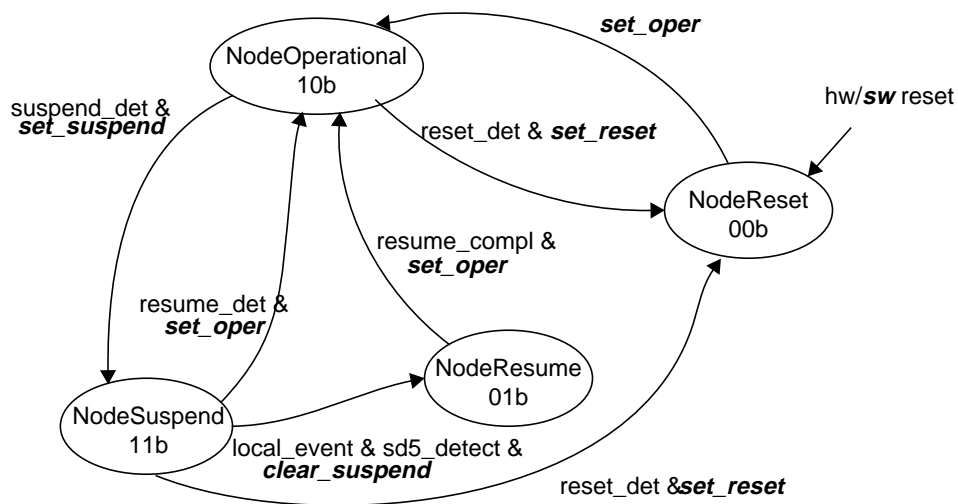

Bold Italics = Transition initiated by firmware

Notes:

1. When the node is not in NodeOperational state, all registers are frozen with the exception of the endpoint controller state machines, and the TX_EN, LAST and RX_EN bits which are reset.
1. In NodeResume state, resume signaling is propagated upstream.
2. In NodeSuspend state, the node may enter a low power state and is able to detect resume signaling.

Figure 18. Node Functional State Diagram

Table 3. Functional States

State Transition	Condition Asserted
set_reset	Node Functional State register NFS[1:0] bits are written with 00 _b The firmware should only initiate set_reset if RESET in the ALTEV register is set.
set_suspend	Node Functional State register NFS[1:0] bits are written with 11 _b The firmware should only initiate set_suspend if SD3 in the ALTEV register is set.
set_oper	Node Functional State register NFS[1:0] bits are written with 10 _b
clear_suspend	Node Functional State register NFS[1:0] bits are written with 01 _b The firmware should only initiate clear_suspend if SD5 in the ALTEV register is set.
reset_det	RESET in the ALTEV register is set to 1
local_event	A local event that should wake up the USB.
sd5_det	SD5 in the ALTEV register is set to 1.
suspend_det	SD3 in the ALTEV register is set to 1.
resume_det	RESUME in the ALTEV register is set to 1.
resume_compl	The node should stay in NodeResume state for at least 10mS and then must enter USB Operational state to detect the EOP from the host, which terminates this Remote Resume operation. EOP is signalled when EOP in the ALTEV register is set to 1.

6.0 Functional Description (Continued)

6.2 ENDPOINT OPERATION

6.2.1 Address Detection

Packets are broadcast from the host controller to all the nodes on the USB network. Address detection is implemented in hardware to allow selective reception of packets and to permit optimal use of microcontroller bandwidth. One function address with seven different endpoint combinations is decoded in parallel. If a match is found, then that particular packet is received into the FIFO; otherwise it is ignored.

The incoming USB Packet Address field and Endpoint field are extracted from the incoming bitstream. Then the address field is compared to the Function Address register (FADR). If a match is detected, the Endpoint field is compared to all of the Endpoint Control registers (EPCx) in parallel. A match then causes the payload data to be received or transmitted using the respective endpoint FIFO.

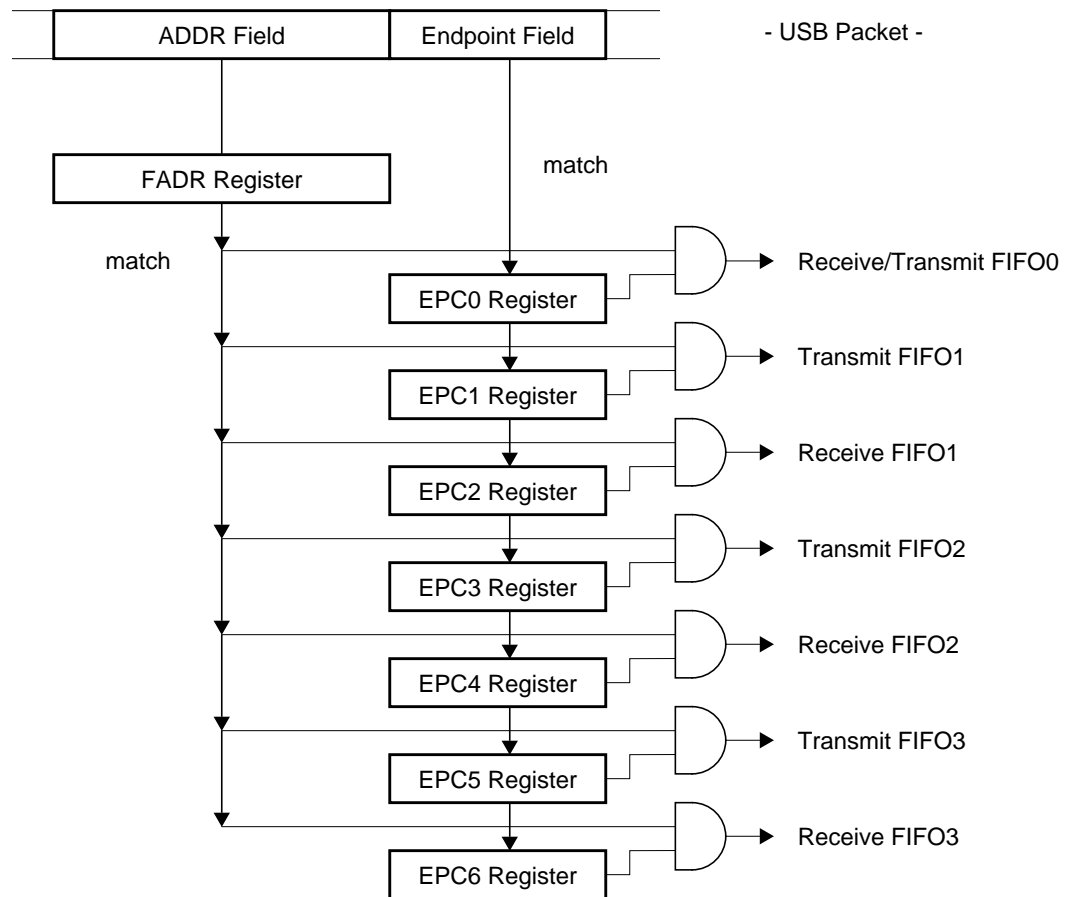

Figure 19. USB Function Address/Endpoint Decoding

6.2.2 Transmit and Receive Endpoint FIFOs

The device uses a total of seven transmit and receive FIFOs: one bidirectional transmit and receive FIFO for the mandatory control endpoint, three transmit FIFOs and three receive FIFOs. As shown in Table 4, the bidirectional FIFO for the control endpoint is 8 bytes deep. The additional unidirectional FIFOs are 64 bytes each for both transmit and receive. Each FIFO can be programmed for one exclusive USB endpoint, used together with one globally decoded USB function address. The firmware must not enable both transmit and receive FIFOs for endpoint zero at any given time.

6.0 Functional Description (Continued)

Table 4. USBN9603/4 Endpoint FIFO Sizes

Endpoint No.	TX FIFO		RX FIFO	
	Size (Bytes)	Name	Size (Bytes)	Name
0	8 FIFO0			
1	64	TXFIFO1		
2			64	RXFIFO1
3	64	TXFIFO2		
4			64	RXFIFO2
5	64	TXFIFO3		
6			64	RXFIFO3

If two endpoints in the same direction are programmed with the same endpoint number and both are enabled, data is received or transmitted to/from the endpoint with the lower number, until that endpoint is disabled for bulk or interrupt transfers, or becomes full or empty for ISO transfers. For example, if receive EP2 and receive EP4 both use endpoint 5 and are both isochronous, the first OUT packet is received into EP2 and the second OUT packet into EP4, assuming no firmware interaction inbetween. For ISO endpoints, this allows implementing a ping-pong buffer scheme together with the frame number match logic.

Endpoints in different directions programmed with the same endpoint number operate independently.

Bidirectional Control Endpoint FIFO0 Operation

FIFO0 should be used for the bidirectional control endpoint zero. It can be configured to receive data sent to the default address with the DEF bit in the EPC0 register. Isochronous transfers are not supported for the control endpoint.

The Endpoint 0 FIFO can hold a single receive or transmit packet with up to 8 bytes of data. Figure 20 shows the basic operation in both receive and transmit direction.

Note: The actual current operating state is not directly visible to the user.

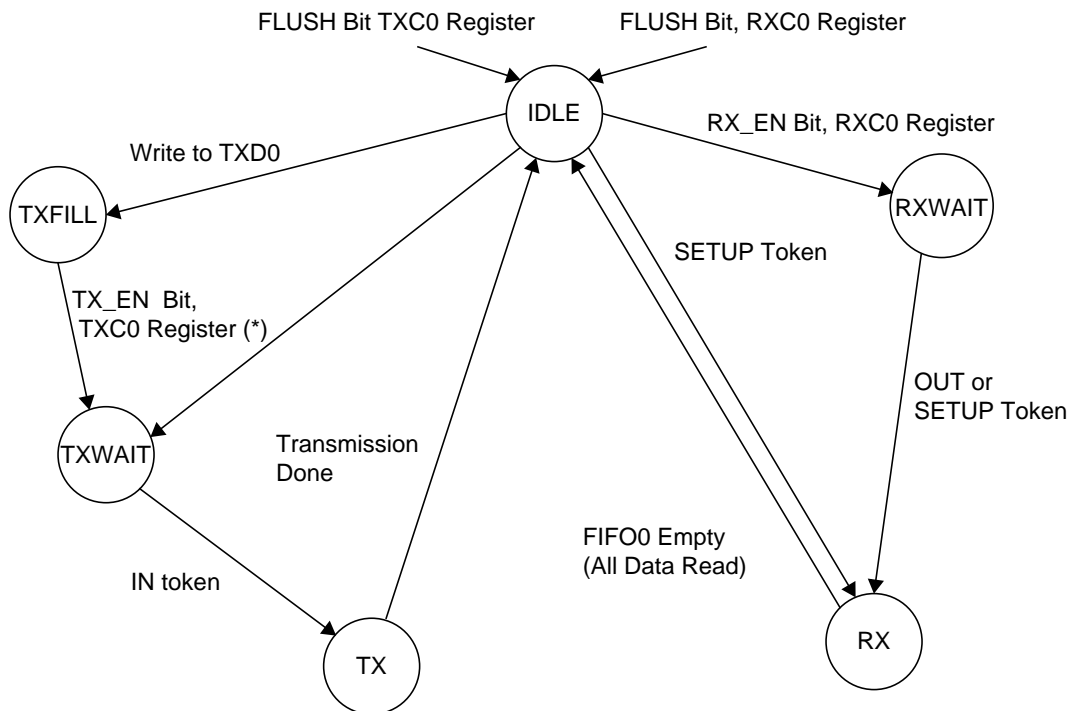

(*) For zero length packet, TX_EN causes a transition from IDLE to TXWAIT

Figure 20. Endpoint 0 Operation

6.0 Functional Description (Continued)

A packet written to the FIFO is transmitted if an IN token for the respective endpoint is received. If an error condition is detected, the packet data remains in the FIFO and transmission is retried with the next IN token.

The FIFO contents can be flushed to allow response to an OUT token or to write new data into the FIFO for the next IN token.

If an OUT token is received for the FIFO, the firmware is informed that the FIFO has received data only if there was no error condition (CRC or STUFF error). Erroneous receptions are automatically discarded.

Transmit Endpoint FIFO Operation (TXFIFO01, TXFIFO02, TXFIFO03)

The Transmit FIFOs for Endpoints 1, 3 and 5 support bulk, interrupt and isochronous USB packet transfers larger than the actual FIFO size. Therefore, the firmware must update the FIFO contents while the USB packet is transmitted on the bus. Figure 21 illustrates the operation of the transmit FIFOs.

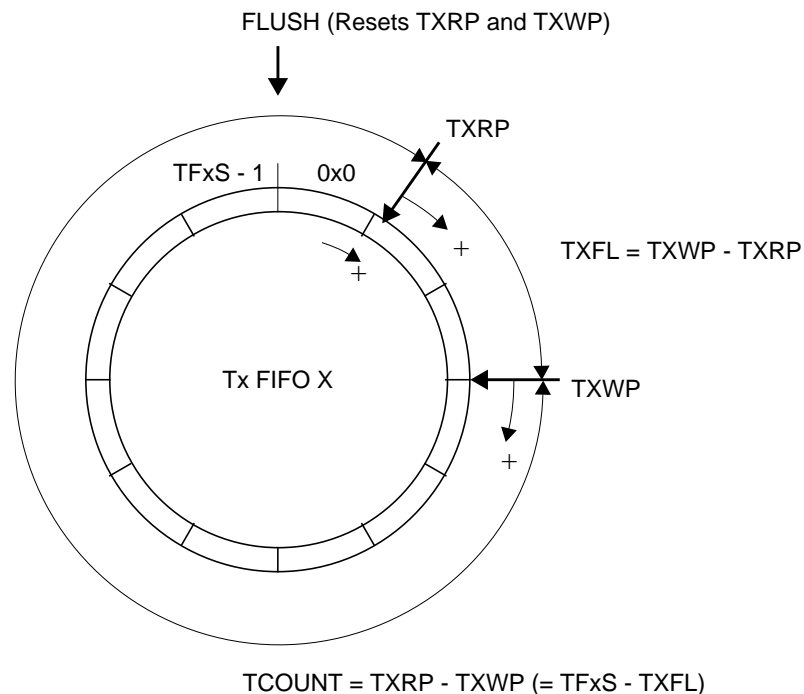

Figure 21. Tx FIFO Operation

TFxS

Transmit FIFO x Size. This is the total number of bytes available within the FIFO.

TXRP

Transmit Read Pointer. This pointer is incremented every time the Endpoint Controller reads from the transmit FIFO. This pointer wraps around to zero if TFxS is reached. TXRP is never incremented beyond the value of the write pointer TXWP.

An underrun condition occurs if TXRP equals TXWP and an attempt is made to transmit more bytes when the LAST bit in the TXCMDx register is not set.

TXWP

Transmit Write Pointer. This pointer is incremented every time the firmware writes to the transmit FIFO. This pointer wraps around to zero if TFxS is reached.

If an attempt is made to write more bytes to the FIFO than actual space available (FIFO overrun), the write to the FIFO is ignored. If so, TCOUNT is checked for an indication of the number of empty bytes remaining.

TXFL

Transmit FIFO Level. This value indicates how many bytes are currently in the FIFO.

A FIFO warning is issued if TXFL decreases to a specific value. The respective WARNx bit in the FWR register is set if TXFL is equal to or less than the number specified by the TFWL bit in the TxCx register.

6.0 Functional Description (Continued)

TCOUNT

Transmit FIFO Count. This value indicates how many empty bytes can be filled within the transmit FIFO. This value is accessible by firmware via the TxSx register.

Receive Endpoint FIFO Operation (RXFIFO1, RXFIFO2, RXFIFO3)

The Receive FIFOs for the Endpoints 2, 4 and 6 support bulk, interrupt and isochronous USB packet transfers larger than the actual FIFO size. If the packet length exceeds the FIFO size, the firmware must read the FIFO contents while the USB packet is being received on the bus. Figure 22 shows the detailed behavior of receive FIFOs.

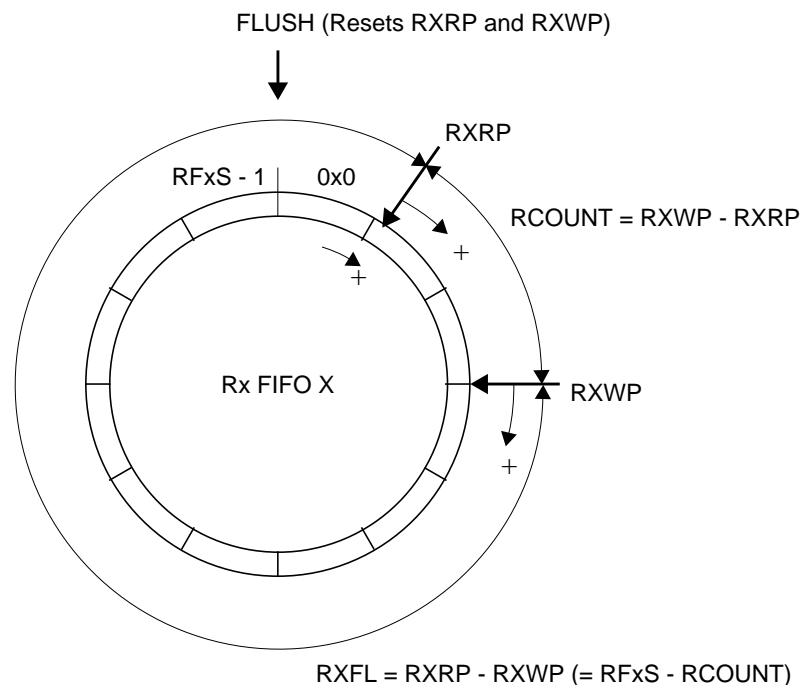

Figure 22. Rx FIFO Operation

RFxS

Receive FIFO x Size. This is the total number of bytes available within the FIFO.

RXRP

Receive Read Pointer. This pointer is incremented with every read of the firmware from the receive FIFO. This pointer wraps around to zero if $RFxS$ is reached. RXRP is never incremented beyond the value of RXWP.

If an attempt is made to read more bytes than are actually available (FIFO underrun), the last byte is read repeatedly.

RXWP

Receive Write Pointer. This pointer is incremented every time the Endpoint Controller writes to the receive FIFO. This pointer wraps around to zero if $RFxS$ is reached.

An overrun condition occurs if $RXRP$ equals $RXWP$ and an attempt is made to write an additional byte.

RXFL

Receive FIFO Level. This value indicates how many more bytes can be received until an overrun condition occurs with the next write to the FIFO.

A FIFO warning is issued if $RXFL$ decreases to a specific value. The respective $WARNx$ bit in the FWR register is set if $RXFL$ is equal to or less than the number specified by the $RFWL$ bit in the $RXCx$ register.

RCOUNT

Receive FIFO Count. This value indicates how many bytes can be read from the receive FIFO. This value is accessible by firmware via the $RXSx$ register.

6.0 Functional Description (Continued)

6.2.3 Programming Model

Figure 23 illustrates the register hierarchy for event reporting.

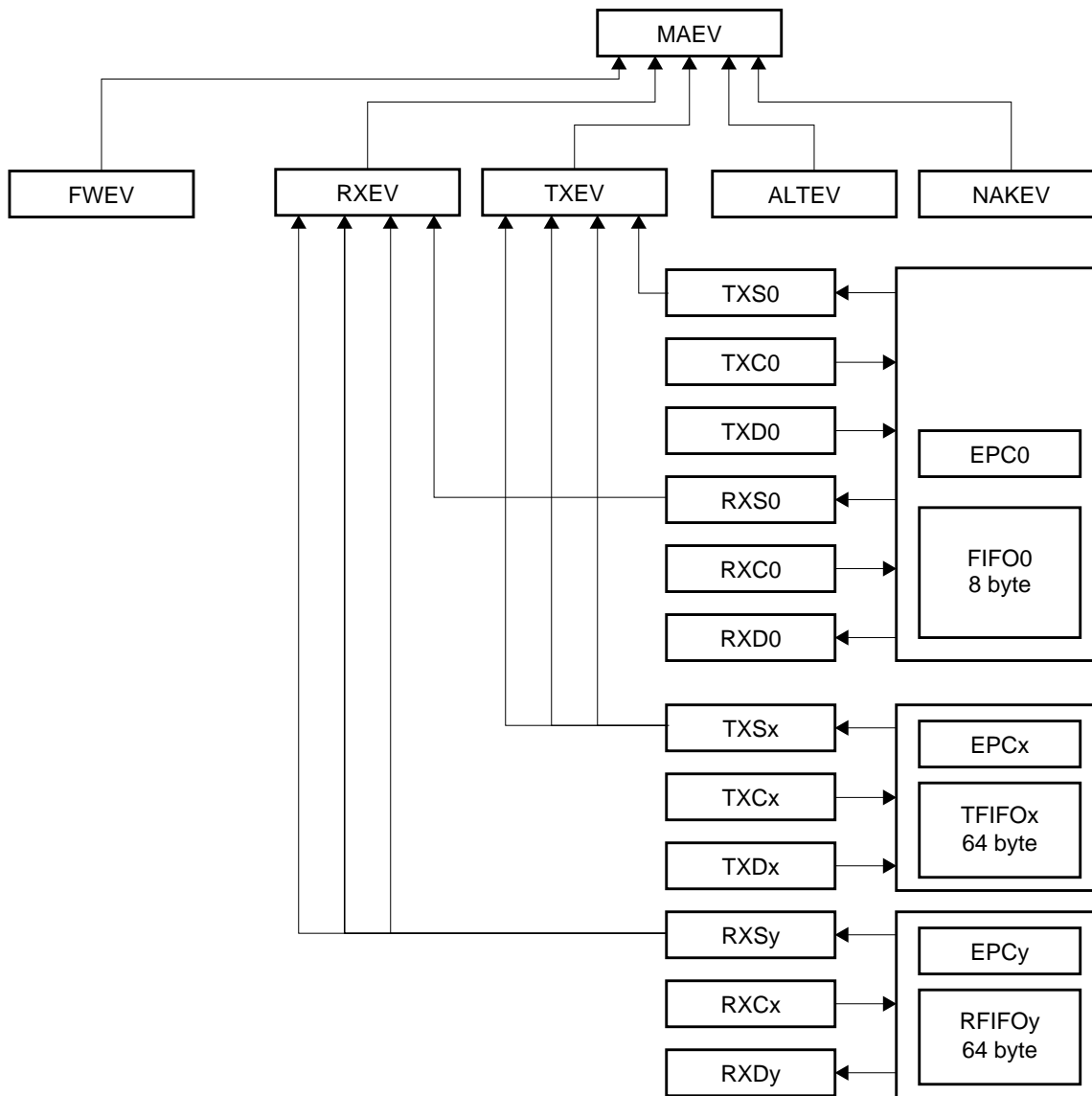

Figure 23. Register Hierarchy

6.3 POWER SAVING MODES

To minimize the power consumption of the USB node, the device can be set to a static Halt mode. During Halt mode, the clock oscillator circuit is disabled, stopping the external 24 MHz clock and 48 MHz frequency doubler, as well as the clock output signal provided on the CLKOUT pin. However, all device internal status and register settings are preserved.

The device is set to Halt mode under the following conditions:

- If Halt On Suspend (HOS) is enabled (the HOS bit in the WKUP register is set to 1), the device enters Halt mode when the node is set in Suspend state. Writing a 1 to HOS after the node is in Suspend state has no effect.
- If the node is not attached, the device enters Halt mode, when the Force Halt bit (FHT) in the Wake-Up register is set to 1.

6.0 Functional Description (Continued)

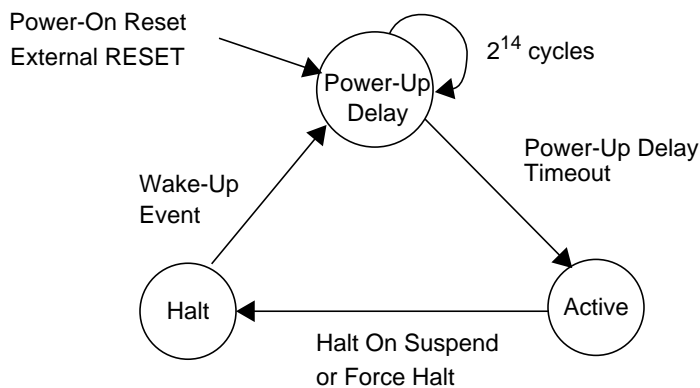

Figure 24. Power Saving Modes

The device exits Halt mode in response to one of the following wake-up events:

- A high-to-low transition is detected on the \overline{CS} pin and the wake-up Enable bit, ENUC in the WKUP register, is set to 1.
- Any activity on the USB is detected (USB not idle) and the wake-up Enable bit, ENUSB in the WKUP register is set to 1. (The node can detect any USB activity only when it is attached.)

When a valid wake-up event is detected, the device returns to active mode after a power-up delay of 2^{14} XIN clock cycles has elapsed (approximately 680 usec). This delay is established by a 14-bit delay counter, which ensures that the 24 MHz oscillator has reached a stable condition and the clock doubler locks and generates a stable 48 MHz signal. After this start-up delay, the clock signal can be output on the CLKOUT pin.

6.4 CLOCK GENERATION

The Clock Generator provides the CLKOUT output signal based on the programming of the Clock Configuration register (CCONF). This allows disabling of the output clock and selection of a clock divisor. The clock divisor supports a programmable output in the range of 48 MHz to 2.82 MHz. On a power-on reset, the output clock defaults to 4 MHz. A software reset has no effect on the programming of the CCONF, and thus no effect on the CLKOUT signal.

The only difference between the USBN9603 and USBN9604 devices is the effect of a hardware reset on the clock generation circuit. In the USBN9604, assertion of the RESET input causes the clock generation circuit to be reset, whereas in the USBN9603, the clock generation circuit is not reset.

In the USBN9603, however, assertion of the \overline{RESET} input does cause all registers to revert to their reset values, including CCONF, which then forces the CLKOUT signal to its default of 4 MHz.

In the USBN9604, assertion of the \overline{RESET} input causes the clock generation circuit to be reset as with the power-on reset. As part of the clock generation reset, a delay of 2^{14} XIN clock cycles is incurred before the CLKOUT signal is output. Assertion of the \overline{RESET} input also causes all registers to revert to their reset values, including CCONF, which then forces the CLKOUT signal to its default of 4 MHz.

This difference is particularly important for bus-powered operations. In such applications, the voltage provided by the bus may fall below acceptable levels for the clock generation circuit. When this occurs, a reset must be applied to this circuit to guarantee proper operation. After a delay of 2^{14} XIN clock cycles, the CLKOUT signal is output. This low voltage detection is typically accomplished in bus-powered applications using a voltage sensor, such as the LP3470, to appropriately reset the CPU and other components, including the USBN9604.

In self-powered applications where there is direct control over the voltage supply, there is no need for the \overline{RESET} input to cause the clock generation circuitry to be reset and the CLKOUT signal to stall for 2^{14} XIN clock cycles. The USBN9603 is thus suited for self-powered applications that use the CLKOUT signal as a system clock.

7.0 Register Set

The device has a set of memory-mapped registers that can be read from/written to control the USB interface. Some register bits are reserved; reading from these bits returns undefined data. Reserved register bits should always be written with 0.

The following conventions are used to describe the register format:

Bit Number	bit 7	bit 6	bit 5	bit 4	bit 3	bit 2	bit 1	bit 0
Bit Mnemonic	Abbreviated bit/field names							
Corresponding FIFO	Corresponding FIFO types and numbers, where relevant							
Reset Value	reset values, where relevant							
Register Type	r = Read only w = Write only r/w = Read and write by firmware CoR = Cleared on read CoW = Cleared on write if written with 0; writing a 1 has no effect HW = Modified by the device and by firmware							

7.1 CONTROL REGISTERS

7.1.1 Main Control Register (MCNTRL)

bit 7	bit 6	bit 5	bit 4	bit 3	bit 2	bit 1	bit 0
INTOC1-0		Reserved		NAT	VGE	Reserved	SRST
0	0	-		0	0		0
r/w		-		r/w	r/w		r/w

SRST

Software Reset. Setting this bit causes a software reset of the device. This reset is equivalent to a hardware reset except that the Clock Configuration (CCONF) register is unaffected. All registers revert to their default values. This bit is cleared automatically upon completion of the initiated reset.

VGE

Voltage Regulator Enable. Setting this bit enables the internal 3.3V voltage regulator. This bit is hardware reset only to a 0, disabling the internal 3.3V regulator by default. When the internal 3.3V regulator is disabled, the device is effectively disconnected from USB. Upon power-up, the firmware may perform any needed initialization (such as power-on self test) and then set the VGE bit. Until the VGE bit is set, the upstream hub port does not detect the device presence.

If the VGE bit is reset an external 3.3V power supply may be used on the V3.3 pin.

NAT

Node Attached. This bit indicates that this node is ready to be detected as attached to USB. When reset the transceiver forces SE0 on the USB port to prevent the hub (to which this node is connected to) from detecting an attach event. After reset, this bit is left cleared to give the device time before it must respond to commands. After this bit is set, the device no longer drives the USB and should be ready to receive Reset signaling from the hub.

The NAT bit should be set by the firmware if an external 3.3V supply has been provided to the V3.3 pin, or at least 1 mS after the VGE bit is set (in the latter case, the delay allows the internal regulator sufficient time to stabilize).

INTOC

Interrupt Output Control. These bits control interrupt output according to the following table.

7.0 Register Set (Continued)

Table 5. Interrupt Output Control Bits

INTOC		Interrupt Output
1	0	
0	0	Disabled
0	1	Active low open drain
1	0	Active high push-pull
1	1	Active low push-pull

7.1.2 Clock Configuration Register (CCONF)

bit 7	bit 6	bit 5	bit 4	bit 3	bit 2	bit 1	bit 0
CODIS	Reserved			CLKDIV3-0			
0	-			1	0	1	1
r/w	-			r/w			

CLKDIV

External Clock Divisor. The power-on reset and a hardware reset configure the divisor to 11_d (decimal format), which yields a 4 MHz output clock.

$$\text{frequency} = 48 \text{ MHz} / (\text{CLKDIV} + 1)$$

If the CLKDIV value is changed by firmware, the clock output is expanded/shortened if the CLKDIV value is increased/decreased in its current phase, to allow glitch-free switching at the CLKOUT pin.

CODIS

Clock Output Disable. Setting this bit disables the clock output. The CLKOUT output signal is frozen in its current state and resumes with a new period when this bit is cleared.

7.1.3 Revision Identifier (RID)

This register holds the binary encoded chip revision.

bit 7	bit 6	bit 5	bit 4	bit 3	bit 2	bit 1	bit 0
Reserved				REVID3-0			
-				0	0	1	0
-				r			

REVID

Revision Identification. For revision 9603 Rev A and 9604 Rev A, the field contains 0010_b .

7.0 Register Set (Continued)

7.1.4 Node Functional State Register (NFSR)

bit 7	bit 6	bit 5	bit 4	bit 3	bit 2	bit 1	bit 0
Reserved						NFS1-0	
-						0	0
-						r/w	

NFS

Node Functional State. The firmware should initiate all required state transitions according to the respective status bits in the Alternate Event (ALTEV) register. The valid transitions are shown in Figure 18. The node functional state bits set the node state, as shown in Table 6.

Table 6. USB Functional States

NFS		Node State	Description
1	0		
0	0	NodeReset	This is the USB Reset state. This is entered upon a module reset or by software upon detection of a USB Reset. Upon entry, all endpoint pipes are disabled. DEF in the Endpoint Control 0 (EPC0) register and AD_EN in the Function Address (FAR) register should be cleared by software on entry to this state. On exit, DEF should be reset so the device responds to the default address.
0	1	NodeResume	In this state, resume "K" signalling is generated. This state should be entered by firmware to initiate a remote wake-up sequence by the device. The node must remain in this state for at least 1 mS and no more than 15 mS.
1	0	NodeOperational	This is the normal operational state. In this state the node is configured for operation on the USB bus.
1	1	NodeSuspend	Suspend state should be entered by firmware on detection of a Suspend event while in Operational state. While in Suspend state, the transceivers operate in their low-power suspend mode. All endpoint controllers and the bits TX_EN, LAST and RX_EN are reset, while all other internal states are frozen. On detection of bus activity, the RESUME bit in the ALTEV register is set. In response, software can cause entry to NodeOperational state.

7.1.5 Main Event Register (MAEV)

bit 7	bit 6	bit 5	bit 4	bit 3	bit 2	bit 1	bit 0
INTR	RX_EV	ULD	NAK	FRAME	TX_EV	ALT	WARN
0	0	0	0	0	0	0	0
see text	r	CoR	r	CoR	r	r	r

WARN

One of the unmasked bits in the FIFO Warning Event (FWEV) register has been set. This bit is cleared by reading the FWEV register.

ALT

Alternate. One of the unmasked ALTEV register bits has been set. This bit is cleared by reading the ALTEV register.

7.0 Register Set (Continued)

TX_EV

Transmit Event. This bit is set if any of the unmasked bits in the Transmit Event (TXEV) register (TXFIFOx or TXUNDRNx) is set. Therefore, it indicates that an IN transaction has been completed. This bit is cleared when all the TX_DONE bits and the TXUNDRN bits in each Transmit Status (TXSx) register are cleared.

FRAME

This bit is set if the frame counter is updated with a new value. This can be due to receipt of a valid SOF packet on the USB or to an artificial update if the frame counter was unlocked or a frame was missed. This bit is cleared when the register is read.

NAK

Negative Acknowledge. One of the unmasked NAK Event (NAKEV) register bits has been set. This bit is cleared when the NAKEV register is read.

ULD

Unlock Locked Detected. The frame timer has either entered unlocked condition from a locked condition, or has re-entered a locked condition from an unlocked condition as determined by the UL bit in the Frame Number (FNH or FNL) register that is set. This bit is cleared when the register is read.

RX_EV

Receive Event. This bit is set if any of the unmasked bits in the Receive Event (RXEV) register is set. It indicates that a SETUP or OUT transaction has been completed. This bit is cleared when all of the RX_LAST bits in each Receive Status (RXSx) register and all RXOVRN bits in the RXEV register are cleared.

INTR

Master Interrupt Enable. This bit is hardwired to 0 in the Main Event (MAEV) register; the corresponding bit in the Main Mask (MAMSK) register is the Master Interrupt Enable.

7.1.6 Main Mask Register (MAMSK)

When set to 1, an interrupt is enabled when the respective event in the MAEV register is enabled. Otherwise, interrupt generation is disabled.

bit 7	bit 6	bit 5	bit 4	bit 3	bit 2	bit 1	bit 0
Same Bit Definition as MAEV Register							
0	0	0	0	0	0	0	0
r/w							

7.1.7 Alternate Event Register (ALTEV)

bit 7	bit 6	bit 5	bit 4	bit 3	bit 2	bit 1	bit 0
RESUME	RESET	SD5	SD3	EOP	DMA	WKUP	res
0	0	0	0	0	0	0	-
CoR	CoR	CoR	CoR	CoR	r	r	-

WKUP

Wake-Up Event. This bit is set when a wake-up interrupt is generated and issued on the external INTR pin. The WKUP bit is read only and cleared when the corresponding wake-up pending bit (PNDUC and/or PNDUSB in the Wake-Up (WKUP) register) is cleared.

DMA

DMA Event. One of the unmasked bits in the DMA Event (DMAEV) register has been set. The DMA bit is read only and cleared when the DMAEV register is cleared.

7.0 Register Set (Continued)

EOP

End of Packet. A valid EOP sequence was detected on the USB. It is used when this device has initiated a Remote wake-up sequence to indicate that the Resume sequence has been acknowledged and completed by the host. This bit is cleared when the register is read.

SD3

Suspend Detect 3 mS. This bit is set after 3 mS of IDLE is detected on the upstream port, indicating that the device should be suspended. The suspend occurs under firmware control by writing the suspend value to the Node Functional State (NFSR) register. This bit is cleared when the register is read.

SD5

Suspend Detect 5 mS. This bit is set after 5 mS of IDLE is detected on the upstream port, indicating that this device is permitted to perform a remote wake-up operation. The resume may be initiated under firmware control by writing the resume value to the NFSR register. This bit is cleared when the register is read.

RESET

This bit is set when 2.5 μ S of SEO is detected on the upstream port. In response, the functional state should be reset (NFS in the NFSR register is set to RESET), where it must remain for at least 100 μ S. The functional state can then return to Operational state. This bit is cleared when the register is read.

RESUME

Resume signalling is detected on USB when the device is in Suspend state (NFS in the NFSR register is set to SUSPEND), and a non IDLE signal is present on USB, indicating that this device should begin its wake-up sequence and enter Operational state. This bit is cleared when the register is read.

7.1.8 Alternate Mask Register (ALTMSK)

A bit set to 1 in this register enables automatic setting of the ALT bit in the MAEV register when the respective event in the ALTEV register occurs. Otherwise, setting ALT bit is disabled.

bit 7	bit 6	bit 5	bit 4	bit 3	bit 2	bit 1	bit 0
Same Bit Definition as ALTEV Register							
0	0	0	0	0	0	0	-
r/w							-

7.1.9 Transmit Event Register (TXEV)

bit 7	bit 6	bit 5	bit 4	bit 3	bit 2	bit 1	bit 0
TXFIFO3	TXFIFO2	TXFIFO1	FIFO0	TXFIFO3	TXFIFO2	TXFIFO1	FIFO0
TXUDRRN3-0				TXFIFO3-0			
0	0	0	0	0	0	0	0
r			1	r			

1. Since Endpoint 0 implements a store and forward principle, an underrun condition for FIFO0 cannot occur. This results in the TXUDRRN0 bit always being read as 0.

TXFIFO

Transmit FIFO. These bits are a copy of the TX_DONE bits from the corresponding Transmit Status (TXSx) registers. The bits are set when the IN transaction for the corresponding transmit endpoint is complete. The bits are cleared when the corresponding TXSx register is read.

TXUDRRN

Transmit Underrun. These bits are copies of the respective TX_URUN bits from the corresponding TXSx registers. Whenever any of the Transmit FIFOs underflow, the respective TXUDRRN bit is set. These bits are cleared when the corresponding Transmit Status register is read.

7.0 Register Set (Continued)

7.1.10 Transmit Mask Register (TXMSK)

When set and the corresponding bit in the TXEV register is set, TX_EV in the MAEV register is set. When cleared, the corresponding bit in the TXEV register does not cause TX_EV to be set.

bit 7	bit 6	bit 5	bit 4	bit 3	bit 2	bit 1	bit 0
Same Bit Definition as TXEV Register							
0	0	0	0	0	0	0	0
r/w							

7.1.11 Receive Event Register (RXEV)

bit 7	bit 6	bit 5	bit 4	bit 3	bit 2	bit 1	bit 0
RXFIFO3	RXFIFO2	RXFIFO1	FIFO0	RXFIFO3	RXFIFO2	RXFIFO1	FIFO0
RXOVRN3-0				RXFIFO3-0			
0	0	0	0	0	0	0	0
CoR				r			

RXFIFO

Receive FIFO. These bits are set whenever either RX_ERR or RX_LAST in the respective Receive Status (RXSx) register is set. Reading the corresponding RXSx register automatically clears these bits.

The device discards all packets for Endpoint 0 received with errors. This is necessary in case of retransmission due to media errors, ensuring that a good copy of a SETUP packet is captured. Otherwise, the FIFO may potentially be tied up, holding corrupted data and unable to receive a retransmission of the same packet (the RXFIFO0 bit does only reflect the value of RX_LAST for Endpoint 0).

If data streaming is used for the receive endpoints (EP2, EP4 and EP6) the firmware must check with the respective RX_ERR bits to ensure the packets received are not corrupted by errors.

RXOVRN

Receive Overrun. These bits are set in the event of a FIFO overrun condition. They are cleared when the register is read.

The firmware must check with the respective RX_ERR bits that packets received for the other receive endpoints (EP2, EP4 and EP6) are not corrupted by errors, as these endpoints support data streaming (packets which are longer than the actual FIFO depth).

7.1.12 Receive Mask Register (RXMSK)

When set and the corresponding bit in the RXEV register is set, RX_EV in the MAEV register is set. When cleared, the corresponding bit in the RXEV register does not cause RX_EV to be set.

bit 7	bit 6	bit 5	bit 4	bit 3	bit 2	bit 1	bit 0
Same Bit Definition as RXEV Register							
0	0	0	0	0	0	0	0
r/w							

7.0 Register Set (Continued)

7.1.13 NAK Event Register (NAKEV)

bit 7	bit 6	bit 5	bit 4	bit 3	bit 2	bit 1	bit 0
RXFIFO3	RXFIFO2	RXFIFO1	FIFO0	TXFIFO3	TXFIFO2	TXFIFO1	FIFO0
OUT3-0				IN3-0			
0	0	0	0	0	0	0	0
CoR				CoR			

IN

Set to 1 when a NAK handshake is generated for an enabled address/endpoint combination (AD_EN in the Function Address, FAR, register is set to 1 and EP_EN in the Endpoint Control, EPCx, register is set to 1) in response to an IN token. This bit is cleared when the register is read.

OUT

Set to 1 when a NAK handshake is generated for an enabled address/endpoint combination (AD_EN in the FAR register is set to 1 and EP_EN in the EPCx register is set to 1) in response to an OUT token. This bit is not set if NAK is generated as result of an overrun condition. It is cleared when the register is read.

7.1.14 NAK Mask Register (NAKMSK)

When set and the corresponding bit in the NAKEV register is set, the NAK bit in the MAEV register is set. When cleared, the corresponding bit in the NAKEV register does not cause NAK to be set.

bit 7	bit 6	bit 5	bit 4	bit 3	bit 2	bit 1	bit 0
Same Bit Definition as NAKEV Register							
0	0	0	0	0	0	0	0
r/w							

7.2 TRANSFER REGISTERS

7.2.1 FIFO Warning Event Register (FWEV)

bit 7	bit 6	bit 5	bit 4	bit 3	bit 2	bit 1	bit 0
RXFIFO3	RXFIFO2	RXFIFO1	-	TXFIFO3	TXFIFO2	TXFIFO1	-
RXWARN3-1			Reserved	TXWARN3-1			Reserved
0	0	0	-	0	0	0	-
r				r			-

TXWARN

Transmit Warning. Set to 1 when the respective transmit endpoint FIFO reaches the warning limit, as specified by the TFWL bits of the respective TXCx register, and transmission from the respective endpoint is enabled. This bit is cleared when the warning condition is cleared by either writing new data to the FIFO when the FIFO is flushed, or when transmission is done, as indicated by the TX_DONE bit in the TXSx register.

RXWARN

Receive Warning. Set to 1 when the respective receive endpoint FIFO reaches the warning limit, as specified by the RFWL bits of the respective EPCx register. This bit is cleared when the warning condition is cleared by either reading data from the FIFO or when the FIFO is flushed.

7.0 Register Set (Continued)

7.2.2 FIFO Warning Mask Register (FWMSK)

When set and the corresponding bit in the FWEV register is set, WARN in the MAEV register is set. When cleared, the corresponding bit in the FWEV register does not cause WARN to be set.

bit 7	bit 6	bit 5	bit 4	bit 3	bit 2	bit 1	bit 0
Same Bit Definition as FWEV Register							
0	0	0	0	0	0	0	0
r/w							

7.2.3 Frame Number High Byte Register (FNH)

bit 7	bit 6	bit 5	bit 4	bit 3	bit 2	bit 1	bit 0
MF	UL	RFC	Reserved		FN10-8		
1	1	0	-		0	0	0
r	r	w/r0	-		r		

FN

Frame Number. This is the current frame number received in the last SOF packet. If a valid frame number is not received within 12060 bit times (Frame Length Maximum, FLMAX, with tolerance) of the previous change, the frame number is incremented artificially. If two successive frames are missed or are incorrect, the current FN is frozen and loaded with the next frame number from a valid SOF packet.

If the frame number low byte was read by firmware before reading the FNH register, the user actually reads the contents of a buffer register which holds the value of the three frame number bits of this register when the low byte was read. Therefore, the correct sequence to read the frame number is: FNL, FNH. Read operations to the FNH register, without first reading the Frame Number Low Byte (FNL) register directly, read the actual value of the three MSBs of the frame number. On reset, FN is set to 0.

RFC

Reset Frame Count. Setting this bit resets the frame number to 0x000, after which this bit clears itself. This bit always reads 0.

UL

Unlock Flag. This bit indicates that at least two frames were received without an expected frame number, or that no valid SOF was received within 12060 bit times. If this bit is set, the frame number from the next valid SOF packet is loaded in FN. On reset, this flag is set to 1.

MF

Missed SOF Flag. This flag is set when the frame number in a valid received SOF does not match the expected next value, or when an SOF is not received within 12060 bit times. On reset, this flag is set to 1.

7.2.4 Frame Number Low Byte Register (FNL)

This register holds the low byte of the frame number, as described above. To ensure consistency, reading this low byte causes the three frame number bits in the FNH register to be locked until this register is read. The correct sequence to read the frame number is: FNL, FNH. On reset, FN is set to 0.

bit 7	bit 6	bit 5	bit 4	bit 3	bit 2	bit 1	bit 0
FN7-0							
0	0	0	0	0	0	0	0
r							

7.0 Register Set (Continued)

7.2.5 Function Address Register (FAR)

This register sets the device function address. The different endpoint numbers are set for each endpoint individually via the Endpoint Control registers.

bit 7	bit 6	bit 5	bit 4	bit 3	bit 2	bit 1	bit 0
AD_EN	AD6-0						
0	0	0	0	0	0	0	0
r/w	r/w						

AD

Address. This field holds the 7-bit function address used to transmit and receive all tokens addressed to the device.

AD_EN

Address Enable. When set to 1, bits AD6-0 are used in address comparison (see Section 6.2 for a description). When cleared, the device does not respond to any token on the USB bus.

Note: If the DEF bit in the Endpoint Control 0 register is set, Endpoint 0 responds to the default address.

7.2.6 DMA Control Register (DMACNTRL)

bit 7	bit 6	bit 5	bit 4	bit 3	bit 2	bit 1	bit 0
DEN	IGNRXTGL	DTGL	ADMA	DMOD	DSRC2-0		
0	0	0	0	0	0		0
r/w	r/w	r/w	r/w	r/w	r/w		

DSRC

DMA Source. The DMA source bit field holds the binary-encoded value that specifies which of the endpoints, 1 to 6, is enabled for DMA support. The DSRC bits are cleared on reset. Table 7 summarizes the DSRC bit settings.

Table 7. DSRC Bit Description

DSRC			Endpoint No.
2	1	0	
0	0	0	1
0	0	1	2
0	1	0	3
0	1	1	4
1	0	0	5
1	0	1	6
1	1	x	Reserved

DMOD

DMA Mode. This bit specifies when a DMA request is issued. If reset, a DMA request is issued on transfer completion. For transmit endpoints EP1, EP3 and EP5, the data is completely transferred as indicated by the TX_DONE bit (to fill the FIFO with new transmit data). For receive endpoints EP2, EP4 and EP6, this is indicated by the RX_LAST bit. When the DMOD bit is set, a DMA request is issued when the respective FIFO warning bit is set. The DMOD bit is cleared on reset.

7.0 Register Set (Continued)

A DMA request from a transmit endpoint is activated until the request condition clears. If DMOD is set to 0, DMA requests are issued either until the firmware reads the respective Transmit Status (TXSx) register, thus resetting the TX_DONE bit, or if the TX_LAST bit in the Transmit Command (TXCx) register is set by firmware. If DMOD is set to 1, DMA requests are issued until the FIFO warning condition clears, either due to sufficient bytes being transferred to the endpoint, or if the TX_DONE bit is set due to a transmission.

DMA requests from a receive endpoint are activated until the request condition clears. If DMOD is set to 0, DMA requests are issued either until the firmware reads the respective Receive Status (RXSx) register, thus resetting the RX_LAST bit, or if the endpoint FIFO becomes empty due to sufficient reads. If DMOD is set to 1, DMA requests are issued until the FIFO warning condition clears, or if the endpoint FIFO becomes empty due to sufficient reads.

If DMOD is set to 0 and the endpoint and DMA are enabled, DMA requests are issued until the firmware reads the respective TXSx or RXSx register, thus resetting the TX_DONE/RX_LAST bit. If DMOD is set to 1 and the endpoint and DMA are enabled, DMA requests are issued until the FIFO warning condition clears.

ADMA

Automatic DMA. Setting this bit automatically enables the selected receive or transmit endpoint. Before ADMA mode can be enabled, the DEN bit in the DMA Control (DMACNTRL) register must be cleared. ADMA mode functions until any bit in the DMA Event (DMAEV) register is set, except for NTGL. To initiate ADMA mode, all bits in the DMAEV register must be cleared, except for NTGL.

For receive operations, the receiver is automatically enabled; when the packet is received, it is transferred via DMA to memory.

For transmit operations, the packet data is transferred via DMA from memory; then the transmitter is automatically enabled.

For ADMA operations, the DMOD bit is ignored. All operations proceed as if DMOD is set to 0.

When the device enters ADMA mode, any existing endpoint state may be lost. If there is already data in the FIFO, it is flushed. The existing state of the RX_EN or TX_EN state may also change.

Clearing ADMA exits ADMA mode. DEN may either be cleared at the same time or later. If at the same time, all DMA operations cease immediately and firmware must transfer any remaining data. If later, the device completes any current DMA operation before exiting ADMA mode (see the description of the DSHLT bit in the DMAEV register for more information).

DTGL

DMA Toggle. This bit is used to determine the initial *state* of ADMA operations. Firmware initially sets this bit to 1 if starting with a DATA1 operation, and to a 0 if starting with a DATA0 operation.

Writes to this bit also update the NTGL bit in the DMAEV register.

IGNRXTGL

Ignore RX Toggle. If this bit is set, the compare between the NTGL bit in the DMAEV register and the TOGGLE bit in the respective RXSx register is ignored during receive operations. In this case, a mismatch of both bits during a receive operation does not stop ADMA operation. If this bit is not set, the ADMA stops in case of a mismatch of the two toggle bits. After reset, this bit is set to 0.

DEN

DMA Enable. This bit enables DMA mode when set. If this bit is reset and the current DMA cycle is completed (or was not yet issued) the DMA transfer is terminated. When the device operates in serial interface mode (MODE1 pin is tied high) DMA mode cannot be enabled, thus setting this bit has no effect. This bit is cleared on reset.

7.2.7 DMA Event Register (DMAEV)

The bits in this register are used with ADMA mode. Bits 0 to 3 may cause an interrupt if not cleared, even if the device is not set to ADMA mode. Until all of these bits are cleared, ADMA mode cannot be initiated. Conversely, ADMA mode is automatically terminated when any of these bits are set.

bit 7	bit 6	bit 5	bit 4	bit 3	bit 2	bit 1	bit 0
Reserved		NTGL	Reserved	DSIZ	DCNT	DERR	DSHLT
-	-	0	-	0	0	-	0
-	-	r	-	CoW	CoW	CoW	CoW

DSHLT

DMA Software Halt. This bit is set when ADMA operations have been halted by firmware. This bit is set only after the DMA engine completes any necessary cleanup operations and returns to Idle state. The following conditions apply:

7.0 Register Set (Continued)

- If the ADMA bit is cleared (but DEN remains set). In this case, the current operation (if any) is completed. This means that any data in the FIFO is either transmitted or transferred to memory by DMA (if receiving). The DSHLT bit is set only after this has occurred. Note that since DEN remains set, it may need to be cleared later. This commonly is done inside the DSHLT interrupt handler.
- If the DEN bit is cleared (ADMA may either remain set, or may be cleared at the same time). This ceases all DMA operations and immediately sets the DSHLT bit. If there is data in the FIFOs, it is retained but not transmitted.
- If the firmware attempts to read the FIFO (if receiving) or write to the FIFO (if transmitting). This ceases all DMA operations and immediately sets the DSHLT bit. The read or write operation may not succeed since this operation is likely to corrupt the FIFO and lose some data.
- If the firmware attempts to read to/write from the corresponding EPCx, TXCx, RXCx, TXSx, or RXSx registers (when DEN and ADMA in the DMACNTRL register are both set). This halts all DMA operations and immediately sets the DSHLT bit. The read or write operation is not effected.

DERR

DMA Error. This bit is set to indicate that a packet has not been received or transmitted correctly. It is also set if the TOGGLE bit in the RXSx/TXSx register does not equal the NTGL bit in the DMAEV register after packet reception/transmission. (Note that this comparison is made before the NTGL bit changes state due to packet transfer).

For receiving, DERR is equivalent to RX_ERR. For transmitting, it is equivalent to TX_DONE (set) and ACK_STAT (not set).

If the AEH bit in the DMA Error Count (DMAERR) register is set, DERR is not set until DMAERRCNT in the DMAERR register is cleared, and another error is detected. Errors are handled as specified in the DMAERR register.

DCNT

DMA Count. This bit is set when the DMA Count (DMACNT) register is 0 (see the DMACNT register for more information).

DSIZ

DMA Size. This bit is only significant for DMA receive operations. It indicates that a packet has been received which is less than the full length of the FIFO. This normally indicates the end of a multi-packet transfer.

NTGL

Next Toggle. This bit determines the toggle state of the next data packet sent (if transmitting), or the expected toggle state of the next data packet (if receiving). This bit is initialized by writing to the DTGL bit of the DMACNTRL register. It then changes state with every packet sent or received on the endpoint presently selected by DSRC2-0. If DTGL write operation occurs simultaneously with the bit update operation, the write takes precedence.

If transmitting, whenever ADMA operations are in progress the DTGL bit overrides the corresponding TOGGLE bit in the TXCx register. In this way, the alternating data toggle occurs correctly on the USB.

Note that there is no corresponding mask bit for this event because it is not used to generate interrupts.

7.2.8 DMA Mask Register (DMAMSK)

Any bit set to 1 in this register enables automatic setting of the DMA bit in the ALTEV register when the respective event in the DMAEV register occurs. Otherwise, setting the DMA bit is disabled. For a description of bits 0 to 3, see the DMAEV register.

bit 7	bit 6	bit 5	bit 4	bit 3	bit 2	bit 1	bit 0
				DSIZ	DCNT	DERR	DSHLT
		-		0	0		0
		-		r/w	r/w	r/w	r/w

7.0 Register Set (Continued)

7.2.9 Mirror Register (MIR)

This is a read only register. Since reading it does not alter the state of the TXSx or RXSx register to which it points, the firmware can freely check the status of the channel.

bit 7	bit 6	bit 5	bit 4	bit 3	bit 2	bit 1	bit 0
STAT							
-							
r							

STAT

Status. This field mirrors the status bits of the transmitter or receiver selected by the DSRC2-0 field in the DMACNTRL register (DMA need not be active or enabled). It corresponds to TXSx or RXSx, respectively.

7.2.10 DMA Count Register (DMACNT)

This register allows a maximum count to be specified for ADMA operations

bit 7	bit 6	bit 5	bit 4	bit 3	bit 2	bit 1	bit 0
DCOUNT7-0							
-							
r/w							

DCOUNT

DMA Count. This field is decremented on completion of a DMA operation until it reaches 0. Then the DCNT bit in the DMA Event register is set, only when the next successful DMA operation is completed. This register does not underflow.

For receive operations, this count decrements when the packet is received successfully, and then transferred to memory via DMA.

For transmit operations, this count decrements when the packet is transferred from memory via DMA, and then transmitted successfully.

DCOUNT should be set as follows: $DCOUNT = (\text{No. of packets to transfer}) - 1$

If a DMACNT write operation occurs simultaneously with the decrement operation, the write takes precedence.

7.2.11 DMA Error Register (DMAERR)

bit 7	bit 6	bit 5	bit 4	bit 3	bit 2	bit 1	bit 0
AEH	DMAERRCNT						
0	0	0	0	0	0	0	0
r/w	r/w						

DMAERRCNT

DMA Error Counter. In conjunction with the automatic error handling feature, this counter defines the maximum number of consecutive bus errors before ADMA mode is stopped. Firmware can set the 7-bit counter to a preset value. Once ADMA is started, the counter decrements from the preset value by 1 every time a bus error is detected. Every successful transaction resets the counter back to the preset value. When ADMA mode is stopped, the counter is also set back to the preset value.

If the counter reaches 0 and another erroneous packet is detected, the DERR bit in the DMA Event register is set. For more information on the effect of setting DERR, see Section 7.2.7. This register cannot underrun.

DMAERRCNT should be set as follows: $DMAERRCNT = 3D$ (Max. no. of allowable transfer attempts) - 1

A write access to this register is only possible when ADMA is inactive. Otherwise, it is ignored. Reading from this register while ADMA is active returns the current counter value. Reading from it while ADMA is inactive returns the preset value. The counter decrements only if AEH is set (automatic error handling activated).

7.0 Register Set (Continued)

AEH

Automatic Error Handling. This bit has two different meanings, depending on the current transaction mode:

- **Non-Isochronous mode**

This mode is used for bulk, interrupt and control transfers. Setting AEH in this mode enables automatic handling of packets containing CRC or bit-stuffing errors.

If this bit is set during transmit operations, the device automatically reloads the FIFO and reschedules the packet to which the host did not return an ACK. If this bit is cleared, automatic error handling ceases.

If this bit is set during receive operations, a packet received with an error (as specified in the DERR bit description in the DMAEV register) is automatically flushed from the FIFO being used so that the packet can be received again. If this bit is cleared, automatic error handling ceases.

- **Isochronous mode**

Setting this bit allows the device to ignore packets received with errors (as specified in the DERR bit description in the DMAMSK register).

If this bit is set during receive operations, the device is automatically flushed and resets the receive FIFO to receive the next packet. The erroneous packet is ignored and not transferred via DMA. If this bit is cleared, automatic error handling ceases.

7.2.12 Wake-Up Register (WKUP)

bit 7	bit 6	bit 5	bit 4	bit 3	bit 2	bit 1	bit 0
FHT	HOS	WKMODE	Reserved	ENUC	ENUSB	PNDUC	PNDUSB
0	0	0	-	1	1	1	1
w/r0	w/r	w/r	-	w/r	w/r	CoW	CoW

PNDUSB

Pending USB Wake-Up. This bit indicates that the device has been woken up by a USB activity. It also signals a pending wake-up interrupt request. The PNDUSB bit must be cleared by the host by writing a 0 to this location. A hardware reset sets this bit.

PNDUC

Pending Microcontroller Wake-Up. This bit indicates that the device has been woken up by a microcontroller access. It also signals a pending wake-up interrupt request. The PNDUC bit must be cleared by the host by writing a 0 to this location. A hardware reset sets this bit.

ENUSB

Enable USB. When set to 1, this bit enables the device to wake up upon detection of USB activity.

ENUC

Enable Microcontroller. When set to 1, this bit enables the device to wake up when the microcontroller accesses the device.

WKMODE

Wake-Up Mode. This bit selects the interval after which the device generates a wake-up interrupt (if enabled) when a valid wake-up event occurs, as follows:

- 0 Generate wake-up interrupt immediately
- 1 Generate wake-up interrupt after a wake-up delay

HOS

Halt On Suspend. When this bit is set, the device enters Halt mode as soon as it is set to Suspend state. Writing a 1 to this location while the node is already in Suspend state is ignored.

FHT

Force Halt. When the node is not attached (NAT in the MCNTRL register is set to 0), setting this bit forces the node into Halt mode. When the node is attached (NAT is set to 1), writing a 1 to this location is ignored.

7.0 Register Set (Continued)

7.2.13 Endpoint Control 0 Register (EPC0)

This register controls mandatory Endpoint Control 0.

bit 7	bit 6	bit 5	bit 4	bit 3	bit 2	bit 1	bit 0
STALL	DEF	Reserved		EP3-0			
0	0	-		0	0	0	0
r/w	r/w	-		r; hardwired to 0			

EP

Endpoint. This field holds the 4-bit endpoint address. For Endpoint 0, these bits are hardwired to 0000_b.

DEF

Default Address. When set, the device responds to the default address regardless of the contents of FAR6-0/EP03-0 fields. When an IN packet is transmitted for the endpoint, the DEF bit is automatically cleared.

This bit aids in the transition from default address to assigned address. The transition from the default address 0000000000_b to an address assigned during bus enumeration may not occur in the middle of the SET_ADDRESS control sequence. This is necessary to complete the control sequence. However, the address must change immediately after this sequence finishes in order to avoid errors when another control sequence immediately follows the SET_ADDRESS command.

On USB reset, the firmware has 10 mS for set-up, and should write 0x80 to the FAR register and 0x00 to the EPC0 register. On receipt of a SET_ADDRESS command, the firmware must write 0x40 to the EPC0 register and 0x80 <assigned_function_address> to the FAR register. It must then queue a zero length IN packet to complete the status phase of the SET_ADDRESS control sequence.

STALL

Setting this bit causes the chip to generate STALL handshakes under the following conditions:

1. The transmit FIFO is enabled and an IN token is received.
2. The receive FIFO is enabled and an OUT token is received.

Note: A SETUP token does not cause a STALL handshake to be generated when this bit is set.

Upon transmitting the STALL handshake, the RX_LAST and the TX_DONE bits in the respective Receive/Transmit Status registers are set.

7.2.14 Transmit Status 0 Register (TXS0)

bit 7	bit 6	bit 5	bit 4	bit 3	bit 2	bit 1	bit 0
Reserved	ACK_STAT	TX_DONE	TCOUNT4-0				
-	0	0	0	0	0	0	0
-	CoR	CoR	r				

TCOUNT

Transmission Count. This bit Indicates the count of empty bytes available in the FIFO. This field is never larger than 8 for Endpoint 0.

TX_DONE

Transmission Done. When set, this bit indicates that a packet has completed transmission. It is cleared when this register is read.

ACK_STAT

Acknowledge Status. This bit indicates the status, as received from the host, of the ACK for the packet previously sent. This bit is to be interpreted when TX_DONE is set to 1. It is set when an ACK is received; otherwise, it remains cleared. This bit is also cleared when this register is read.

7.0 Register Set (Continued)

7.2.15 Transmit Command 0 Register (TXC0)

bit 7	bit 6	bit 5	bit 4	bit 3	bit 2	bit 1	bit 0
Reserved			IGN_IN	FLUSH	TOGGLE	Reserved	TX_EN
-			0	0	0	-	0
-			r/w	r/w HW	r/w	-	r/w HW

TX_EN

Transmission Enable. This bit enables data transmission from the FIFO. It is cleared by the chip after transmitting a single packet, or a STALL handshake, in response to an IN token. It must be set by firmware to start packet transmission. The RX_EN bit in the Receive Command 0 (RXC0) register takes precedence over this bit; i.e. if RX_EN is set, TX_EN bit is ignored until RX_EN is reset.

Zero length packets are indicated by setting this bit without writing any data to the FIFO.

TOGGLE

This bit specifies the PID used when transmitting the packet. A value of 0 causes a DATA0 PID to be generated, while a value of 1 causes a DATA1 PID to be generated. This bit is not altered by the hardware.

FLUSH

Writing a 1 to this bit flushes all data from the control endpoint FIFOs, resets the endpoint to Idle state, clears the FIFO read and write pointer, and then clears itself. If the endpoint is currently using the FIFO0 to transfer data on USB, flushing is delayed until after the transfer is done. This bit is cleared on reset. It is equivalent to the FLUSH bit in the RXC0 register.

IGN_IN

Ignore IN tokens. When this bit is set, the endpoint will ignore any IN tokens directed to its configured address.

7.2.16 Transmit Data 0 Register (TXD0)

bit 7	bit 6	bit 5	bit 4	bit 3	bit 2	bit 1	bit 0
TXFD							
-							
r/w							

TXFD

Transmit FIFO Data Byte. See “Bidirectional Control Endpoint FIFO0 Operation” in Section 6.2.2 for a description of data handling.

The firmware is expected to write only the packet payload data. The PID and CRC16 are created automatically.

7.2.17 Receive Status 0 Register (RXS0)

This is the Receive Status register for the bidirectional Control Endpoint 0. To receive a SETUP packet after receiving a zero length OUT/SETUP packet, there are two copies of this register in hardware. One holds the receive status of a zero length packet, and another holds the status of the next SETUP packet with data. If a zero length packet is followed by a SETUP packet, the first read of this register indicates the status of the zero length packet (with RX_LAST set to 1 and RCOUNT set to 0) and the second read indicates the status of the SETUP packet.

bit 7	bit 6	bit 5	bit 4	bit 3	bit 2	bit 1	bit 0
Reserved	SETUP	TOGGLE	RX_LAST	RCOUNT3-0			
-	0	0	0	0	0	0	0
-	CoR	CoR	CoR	r			

RCOUNT

Receive Count. Indicates the count of bytes presently in the RX FIFO. This field is never larger than 8 for Endpoint 0.

7.0 Register Set (Continued)

RX_LAST

Receive Last Bytes. Indicates that an ACK was sent upon completion of a successful receive operation. This bit is unchanged for zero length packets. It is cleared when this register is read.

TOGGLE

This bit specified the PID used when receiving the packet. A value of 0 indicates that the last successfully received packet had a DATA0 PID, while a value of 1 indicates that this packet had a DATA1 PID. This bit is unchanged for zero length packets. It is cleared when this register is read.

SETUP

This bit indicates that the setup packet has been received. This bit is unchanged for zero length packets. It is cleared when this register is read.

7.2.18 Receive Command 0 Register (RXC0)

bit 7	bit 6	bit 5	bit 4	bit 3	bit 2	bit 1	bit 0
Reserved				FLUSH	IGN_SETUP	IGN_OUT	RX_EN
-				0	0	0	0
-				r/w HW	r/w	r/w	r/w

RX_EN

Receive Enable. OUT packet reception is disabled after every data packet is received, or when a STALL handshake is returned in response to an OUT token. A 1 must be written to this bit to re-enable data reception. Reception of SETUP packets is always enabled. In the case of back-to-back SETUP packets (for a given endpoint) where a valid SETUP packet is received with no other intervening non-SETUP tokens, the Endpoint Controller discards the new SETUP packet and returns an ACK handshake. If any other reasons prevent the Endpoint Controller from accepting the SETUP packet, it must not generate a handshake. This allows recovery from a condition where the ACK of the first SETUP token was lost by the host.

IGN_OUT

Ignore OUT tokens. When this bit is set, the endpoint ignores any OUT tokens directed to its configured address.

IGN_SETUP

Ignore SETUP tokens. When this bit is set, the endpoint ignores any SETUP tokens directed to its configured address.

FLUSH

Writing a 1 to this bit flushes all data from the control endpoint FIFOs, resets the endpoint to Idle state, clears the FIFO read and write pointer, and then clears itself. If the endpoint is currently using FIFO0 to transfer data on USB, flushing is delayed until after the transfer is done. This bit is cleared on reset. This bit is equivalent to FLUSH in the TXC0 register.

7.2.19 Receive Data 0 Register (RXD0)

bit 7	bit 6	bit 5	bit 4	bit 3	bit 2	bit 1	bit 0
RXFD							
-							
r/w							

RXFD

Receive FIFO Data Byte. See "Bidirectional Control Endpoint FIFO0 Operation" in Section 6.2.2 for a description of data handling.

The firmware should expect to read only the packet payload data. The PID and CRC16 are removed from the incoming data stream automatically.

7.0 Register Set (Continued)

7.2.20 Endpoint Control X Register (EPC1 to EPC6)

Each unidirectional endpoint has an EPCx register with the bits defined below.

bit 7	bit 6	bit 5	bit 4	bit 3	bit 2	bit 1	bit 0
STALL	Reserved	ISO	EP_EN	EP3-0			
0	-	0	0	0	0	0	0
r/w	-	r/w	r/w	r/w			

EP

Endpoint. This field holds the 4-bit endpoint address.

EP_EN

Endpoint Enable. When this bit is set, the EP3-0 field is used in address comparison, together with the AD6-0 field in the FAR register. See Section 6.2 for a description. When cleared, the endpoint does not respond to any token on the USB bus.

Note: AD_EN in the FAR register is the global address compare enable for the device. If it is cleared, the device does not respond to any address, regardless of the EP_EN state.

ISO

Isochronous. When this bit is set to 1, the endpoint is isochronous. This implies that no NAK is sent if the endpoint is not ready but enabled; i.e. if an IN token is received and no data is available in the FIFO to transmit, or if an OUT token is received and the FIFO is full since there is no USB handshake for isochronous transfers.

STALL

Setting this bit causes the chip to generate STALL handshakes under the following conditions:

1. The transmit FIFO is enabled and an IN token is received.
2. The receive FIFO is enabled and an OUT token is received.

Setting this bit does not generate a STALL handshake in response to a SETUP token.

7.2.21 Transmit Status X Register (TXS1, TXS2, TXS3)

Each of the three transmit endpoint FIFOs has a Transmit Status register with the bits defined below.

bit 7	bit 6	bit 5	bit 4	bit 3	bit 2	bit 1	bit 0
TX_URUN	ACK_STAT	TX_DONE	TCOUNT4-0				
0	0	0	0	0	0	0	0
CoR	CoR	CoR	r				

TCOUNT

Transmission Count. This bit indicates the count of empty bytes available in the FIFO. If this count is greater than 31, a value of 31 is reported.

TX_DONE

Transmission Done. When set, this bit indicates that the endpoint responded to a USB packet. Three conditions can cause this bit to be set:

1. A data packet completed transmission in response to an IN token with non-ISO operation.
2. The endpoint sent a STALL handshake in response to an IN token
3. A scheduled ISO frame was transmitted or discarded.

This bit is cleared when this register is read.

ACK_STAT

Acknowledge Status. This bit is interpreted when TX_DONE is set. Its function differs depending on whether ISO (ISO in the EPCx register is set) or non-ISO operation (ISO is reset) is used.

For non-ISO operation, this bit indicates the acknowledge status (from the host) about the ACK for the previously sent packet. This bit itself is set when an ACK is received; otherwise, it is cleared.

7.0 Register Set (Continued)

For ISO operation, this bit is set if a frame number LSB match (see “IGN_ISOMSK” bit in Section 7.2.22) occurs, and data was sent in response to an IN token. Otherwise, this bit is reset, the FIFO is flushed and TX_DONE is set.

This bit is also cleared when this register is read.

TX_URUN

Transmit FIFO Underrun. This bit is set if the transmit FIFO becomes empty during a transmission, and no new data is written to the FIFO. If so, the Media Access Controller (MAC) forces a bit stuff error followed by an EOP. This bit is reset when this register is read.

7.2.22 Transmit Command X Register (TXC1, TXC2, TXC3)

Each of the transmit endpoints (1, 3 and 5) has a Transmit Command register with the bits defined below.

bit 7	bit 6	bit 5	bit 4	bit 3	bit 2	bit 1	bit 0
IGN_ISOMSK	TFWL1-0		RFF	FLUSH	TOGGLE	LAST	TX_EN
0	0	0	0	0	0	0	0
r/w	r/w		r/w HW	r/w HW	r/w	r/w HW	r/w HW

TX_EN

Transmission Enable. This bit enables data transmission from the FIFO. It is cleared by the chip after transmitting a single packet or after a STALL handshake in response to an IN token. It must be set by firmware to start packet transmission.

LAST

Setting this bit indicates that the entire packet has been written to the FIFO. This is used especially for streaming data to the FIFO while the actual transmission occurs. If the LAST bit is not set and the transmit FIFO becomes empty during a transmission, a stuff error followed by an EOP is forced on the bus. Zero length packets are indicated by setting this bit without writing any data to the FIFO.

The transmit state machine transmits the payload data, CRC16 and the EOP signal before clearing this bit.

TOGGLE

The function of this bit differs depending on whether ISO (ISO in the EPCx register is set) or non-ISO operation (ISO is reset) is used.

For non-ISO operation, it specifies the PID used when transmitting the packet. A value of 0 causes a DATA0 PID to be generated, while a value of 1 causes a DATA1 PID to be generated.

For ISO operation, this bit and the LSB of the frame counter (FNL0) act as a mask for the TX_EN bit to allow pre-queueing of packets to specific frame numbers; i.e. transmission is enabled only if bit 0 in the FNL register is set to TOGGLE. If an IN token is not received while this condition is true, the contents of the FIFO are flushed with the next SOF. If the endpoint is set to ISO, data is always transferred with a DATA0 PID.

This bit is not altered by hardware.

FLUSH

Writing a 1 to this bit flushes all data from the corresponding transmit FIFO, resets the endpoint to Idle state, and clears both the FIFO read and write pointers. If the MAC is currently using the FIFO to transmit, data is flushed after the transmission is complete. After data flushing, this bit is reset by hardware.

RFF

Refill FIFO. Setting the LAST bit automatically saves the Transmit Read Pointer (TXRP) to a buffer. When the RFF bit is set, the buffered TXRP is reloaded into the TXRP. This allows the user to repeat the last transaction if no ACK was received from the host. If the MAC is currently using the FIFO to transmit, TXRP is reloaded only after the transmission is complete. After reload, this bit is reset by hardware.

TFWL

Transmit FIFO Warning Limit. These bits specify how many more bytes can be transmitted from the respective FIFO before an underrun condition occurs. If the number of bytes remaining in the FIFO is equal to or less than the selected warning limit, the TXWARN bit in the FWEV register is set. To avoid interrupts caused by setting this bit while the FIFO is being filled before a transmission begins, TXWARN is only set when transmission from the endpoint is enabled (TX_ENx in the TXCx register is set). See Table 8.

7.0 Register Set (Continued)

Table 8. Set Transmit FIFO Warning Limit

TFWL		Bytes Remaining in FIFO
1	0	
0	0	TFWL disabled
0	1	≤ 4
1	0	≤ 8
1	1	≤ 16

IGN_ISOMSK

Ignore ISO Mask. This bit has an effect only if the endpoint is set to be isochronous. If set, this bit disables locking of specific frame numbers with the alternate function of the TOGGLE bit. Thus data is transmitted upon reception of the next IN token. If reset, data is only transmitted when FNL0 matches TOGGLE. This bit is cleared on reset.

7.2.23 Transmit Data X Register (TXD1, TXD2, TXD3)

Each transmit FIFO has one Transmit Data register with the bits defined below.

bit 7	bit 6	bit 5	bit 4	bit 3	bit 2	bit 1	bit 0
TXFD							
-							
w							

TXFD

Transmit FIFO Data Byte. See “Transmit Endpoint FIFO Operation (TXFIFO1, TXFIFO2, TXFIFO3)” in Section 6.2.2 for a description of endpoint FIFO data handling. The firmware is expected to write only the packet payload data. PID and CRC16 are inserted automatically in the transmit data stream.

7.2.24 Receive Status X Register (RXS1, RXS2, RXS3)

Each receive endpoint pipe (2, 4 and 6) has one Receive Status register with the bits defined below. To allow a SETUP packet to be received after a zero length OUT packet is received, hardware contains two copies of this register. One holds the receive status of a zero length packet, and another holds the status of the next SETUP packet with data. If a zero length packet is followed by a SETUP packet, the first read of this register indicates the zero length packet status, and the second read, the SETUP packet status.

bit 7	bit 6	bit 5	bit 4	bit 3	bit 2	bit 1	bit 0
RX_ERR	SETUP	TOGGLE	RX_LAST	RCOUNT3-0			
0	0	0	0	0	0	0	0
CoR	CoR	CoR HW	CoR	r			

RCOUNT

Receive Count. This bit indicates the count of bytes presently in the endpoint receive FIFO. If this count is greater than 15, a value of 15 is reported.

RX_LAST

Receive Last. This bit indicates that an ACK was sent upon completion of a successful receive operation. This bit is cleared when this register is read.

TOGGLE

The function of this bit differs depending on whether ISO (ISO in the EPCx register is set) or non-ISO operation (ISO is reset) is used.

For non-ISO operation, a value of 0 indicates that the last successfully received packet had a DATA0 PID, while a value of 1 indicates that this packet had a DATA1 PID.

7.0 Register Set (Continued)

For ISO operation, this bit reflects the LSB of the frame number (FNL0) after a packet was successfully received for this endpoint.

This bit is reset to 0 by reading the RXSx register.

SETUP

This bit indicates that the setup packet has been received. It is cleared when this register is read.

RX_ERR

Receive Error. When set, this bit indicates a media error, such as bit-stuffing or CRC. If this bit is set, the firmware must flush the respective FIFO.

7.2.25 Receive Command X Register (RXC1, RXC2, RXC3)

Each of the receive endpoints (2, 4 and 6) has one Receive Command register with the bits defined below.

bit 7	bit 6	bit 5	bit 4	bit 3	bit 2	bit 1	bit 0
Reserved	RFWL1-0		Reserved	FLUSH	IGN_SETUP	Reserved	RX_EN
-	0	0	-	0	0	-	0
-	r/w		-	r/w	r/w	-	r/w

RX_EN

Receive Enable. OUT packet cannot be received after every data packet is received, or when a STALL handshake is returned in response to an OUT token. This bit must be written with a 1 to re-enable data reception. SETUP packets can always be received. In the case of back-to-back SETUP packets (for a given endpoint) where a valid SETUP packet has been received with no other intervening non-SETUP tokens, the receive state machine discards the new SETUP packet and returns an ACK handshake. If, for any other reason, the receive state machine cannot accept the SETUP packet, no HANDSHAKE should be generated.

IGN_SETUP

Ignore SETUP Tokens. When this bit is set, the endpoint ignores any SETUP tokens directed to its configured address.

FLUSH

Writing a 1 to this bit flushes all data from the corresponding receive FIFO, resets the endpoint to Idle state, and resets both the FIFO read and write pointers. If the MAC is currently using the FIFO to receive data, flushing is delayed until after receiving is completed.

RFWL1-0

Receive FIFO Warning Limit. These bits specify how many more bytes can be received to the respective FIFO before an overrun condition occurs. If the number of empty bytes remaining in the FIFO is equal to or less than the selected warning limit, the RXWARN bit in the FWEV register is set.

Table 9. Set Receive FIFO Warning Limit

RFWL Bits		Bytes Remaining in FIFO
1	0	
0	0	RFWL disabled
0	1	≤ 4
1	0	≤ 8
1	1	≤ 16

7.0 Register Set (Continued)

7.2.26 Receive Data X Register (RXD1, RXD2, RXD3)

Each of the three Receive Endpoint FIFOs has one Receive Data register with the bits defined below.

bit 7	bit 6	bit 5	bit 4	bit 3	bit 2	bit 1	bit 0
RXFD							
-							
r							

RXFD

Receive FIFO Data Byte. See "Receive Endpoint FIFO Operation (RXFIFO1, RXFIFO2, RXFIFO3)" in Section 6.2.2 for a description of Endpoint FIFO data handling.

The firmware should expect to read only the packet payload data. The PID and CRC16 are terminated by the receive state machine.

7.3 REGISTER MAP

Table 10 lists all device registers, their addresses and their abbreviations.

Table 10. USBN9603/4 Memory Map

Address	Register Mnemonic	Register Name
0x00	MCNTRL	Main Control
0x01	CCONF	Clock Configuration
0x02		Reserved
0x03	RID	Revision Identifier
0x04	FAR	Function Address
0x05	NFSR	Node Functional State
0x06	MAEV	Main Event
0x07	MAMSK	Main Mask
0x08	ALTEV	Alternate Event
0x09	ALMSK	Alternate Mask
0x0A	TXEV	Transmit Event
0x0B	TXMSK	Transmit Mask
0x0C	RXEV	Receive Event
0x0D	RXMSK	Receive Mask
0x0E	NAKEV	NAK Event
0x0F	NAKMSK	NAK Mask
0x10	FWEV	FIFO Warning Event
0x11	FWMSK	FIFO Warning Mask
0x12	FNH	Frame Number High Byte
0x13	FNL	Frame Number Low Byte
0x14	DMACNTRL	DMA Control
0x15	DMAEV	DMA Event
0x16	DMAMSK	DMA Mask
0x17	MIR	Mirror

7.0 Register Set (Continued)

Address	Register Mnemonic	Register Name
0x18	DMACNT	DMA Count
0x19	DMAERR	DMA Error Count
0x1A		Reserved
0x1B	WKUP	Wake-Up
0x1C - 0x1F		Reserved
0x20	EPC0	Endpoint Control 0
0x21	TXD0	Transmit Data 0
0x22	TXS0	Transmit Status 0
0x23	TXC0	Transmit Command 0
0x24		Reserved
0x25	RXD0	Receive Data 0
0x26	RXS0	Receive Status 0
0x27	RXC0	Receive Command 0
0x28	EPC1	Endpoint Control 1
0x29	TXD1	Transmit Data 1
0x2A	TXS1	Transmit Status 1
0x2B	TXC1	Transmit Command 1
0x2C	EPC2	Endpoint Control 2
0x2D	RXD1	Receive Data 1
0x2E	RXS1	Receive Status 1
0x2F	RXC1	Receive Command 1
0x30	EPC3	Endpoint Control 3
0x31	TXD2	Transmit Data 2
0x32	TXS2	Transmit Status 2
0x33	TXC2	Transmit Command 2
0x34	EPC4	Endpoint Control 4
0x35	RXD2	Receive Data 2
0x36	RXS2	Receive Status 2
0x37	RXC2	Receive Command 2
0x38	EPC5	Endpoint Control 5
0x39	TXD3	Transmit Data 3
0x3A	TXS3	Transmit Status 3
0x3B	TXC3	Transmit Command 3
0x3C	EPC6	Endpoint Control 6
0x3D	RXD3	Receive Data 3
0x3E	RXS3	Receive Status 3
0x3F	RXC3	Receive Command 3

8.0 Device Characteristics

8.1 ABSOLUTE MAXIMUM RATINGS

Absolute maximum ratings indicate limits beyond which damage to the device may occur.

Supply Voltage	-0.5V to +7.0V
DC Input Voltage	-0.5V to $V_{CC} + 0.5V$
DC Output Voltage	-0.5V to $V_{CC} + 0.5V$
Storage Temperature	-65°C to +150°C
Lead Temperature (Soldering 10 seconds)	260°C
ESD Rating ¹	4.5 KV

1. Human body model; 100 pF discharged through a 1.5 K Ω resistor

8.2 DC ELECTRICAL CHARACTERISTICS

(3.0V < V_{CC} < 5.5V, 0°C < T_A < +70°C, unless otherwise specified)

Symbol	Parameter	Conditions	Min	Typ	Max	Units
Operating Ratings						
V_{CC}	Supply Voltage ¹		3.0	5.0	5.5	V
I_{CC1}	Operating Supply Current			30	40	mA
I_{CC2}	Standby Supply Current ²			5	10	mA
I_{CCQ}	Halt Current: 3.3V Operation ³			1	2	μ A
	Halt Current: 5V Operation ¹			250	400	μ A
T_{amb}	Operating Temperature Range		0		+70	°C
USB Signals						
V_{DI}	Differential Input Sensitivity	(D+) - (D-)	-0.2		0.2	V
V_{CM}	Differential Common Mode Range		0.8		2.5	V
V_{SE}	Single Ended Receiver Threshold		0.8		2.0	V
V_{OL}	Output Low Voltage	$R_L = 1.5K$ to 3.6V			0.3	V
V_{OH}	Output High Voltage		2.8			V
I_{OZ}	Tri-state Data Line Leakage	$0V < V_{IN} < 3.3V$	-10		10	μ A
C_{TRN}	Transceiver Capacitance				20	pF
Digital Input/Output Signals (RESET, MODE, CLKOUT, AD0-AD7, WR, RD, A0)						
V_{OH}	Output High Voltage	$I_{OH} = -6$ mA ($V_{CC} = 5V$) $I_{OH} = -4$ mA ($V_{CC} = 3.3V$)	2.4			V
V_{OL}	Output Low Voltage	$I_{OL} = 6$ mA			0.4	V
V_{IH}	Input High Voltage		2.0			V

8.0 Device Characteristics (Continued)

Symbol	Parameter	Conditions	Min	Typ	Max	Units
V_{IL}	Input Low Voltage				0.8	V
I_{IL}	Input Low Current	$V_{IN} = GND$			-10	μA
I_{IH}	Input High Current	$V_{IN} = V_{CC}$			10	μA
I_{OZ}	Tri-state Leakage	$V_{OUT} = V_{CC}$ or GND	-10		10	μA
Oscillator Input/Output Signals (XTALIN, XTALOUT)						
V_{IH}	Input High Switching Level				1.8	V
V_{IL}	Input Low Switching Level				1.0	V
C_{XIN}	Input Capacitance ⁴				4.0	pF
C_{XOUT}	Output Capacitance				4.0	pF
Voltage Regulator (3.3V)						
V_O	Output Voltage ⁵		3.0		3.6	V

1. The internal voltage regulator is enabled.
2. CLKOUT is not driven and the device is not accessed.
3. The internal voltage regulator is disabled.
4. Not tested. Guaranteed by design.
5. The internal voltage regulator is intended to power only the internal transceivers and one external pull-up. An external de-coupling capacitor is connected to this pin.

8.3 AC ELECTRICAL CHARACTERISTICS

($3.0V < V_{CC} < 5.5V$, $0^\circ C < TA < +70^\circ C$, unless otherwise specified)

Symbol	Parameter	Conditions ^{1 2}	Min	Typ	Max	Units
Full Speed Signaling (D+, D-)						
T_R	Rise Time	$C_L = 50pF$	4		20	nS
T_F	Fall Time	$C_L = 50pF$	4		20	nS
T_{RFM}	Rise / Fall Time Matching (T_R / T_F)	$C_L = 50pF$	90		110	%
V_{CRS}	Output Signal Crossover Voltage	$C_L = 50pF$	1.3		2.0	V
Z_{DRV}	Driver Output Impedance (Single Ended)	$C_L = 50pF$	28		43	Ω
Clock Out Characteristics (CLKOUT)						
T_R	Output Rise Time	$C_L = 50pF$			10	nS
T_F	Output Fall Time	$C_L = 50pF$			10	nS
T_{CYCLE}	Output Duty Cycle	$F_{out} < 48MHz$	45		55	%

1. Testing is centered around 50 W, not 45 W +/- 15% as specified in USB spec. rev 1.1.
2. Waveforms are measured from 10% to 90%.

8.0 Device Characteristics (Continued)

Note: CKI in the following tables refers to the internal clock of the device and not to the signal frequency applied at XIN.

8.4 PARALLEL INTERFACE TIMING (MODE1-0 = 00_B)

($3.0V < V_{CC} < 5.5V$, $0^{\circ}C < T_A < +70^{\circ}C$, unless otherwise specified)

Symbol	Parameter	Conditions	Min	Typ	Max	Units
t_{AS}	Address Setup Time	$C_L = 50 \text{ pF}$	0			nS
t_{AH}	Address Hold Time	$C_L = 50 \text{ pF}$	0			nS
t_{RW}	Read Pulse Width ¹	$C_L = 50 \text{ pF}$	1/CKI			nS
t_{RC}	Read Cycle Time ^{2 3}	$C_L = 50 \text{ pF}$	3/MCLK			nS
t_{RDV}	Data Output Valid after Read Low	$C_L = 50 \text{ pF}$		20	30	nS
t_{RDH}	Data Output Hold after Read High	$C_L = 50 \text{ pF}$	2			nS
t_{WW}	Write Pulse Width ¹	$C_L = 50 \text{ pF}$	1/CKI			nS
t_{WC}	Write Cycle Time ^{2 3}	$C_L = 50 \text{ pF}$	3/MCLK			nS
t_{DS}	Data Input Setup Time	$C_L = 50 \text{ pF}$	25			nS
t_{DH}	Data Input Hold Time	$C_L = 50 \text{ pF}$	8			nS

1. Clock Internal: CKI = 48 MHz on this device
2. Memory Clock: MCLK = CKI/4 = 12 MHz
3. Time until next read or write occurs

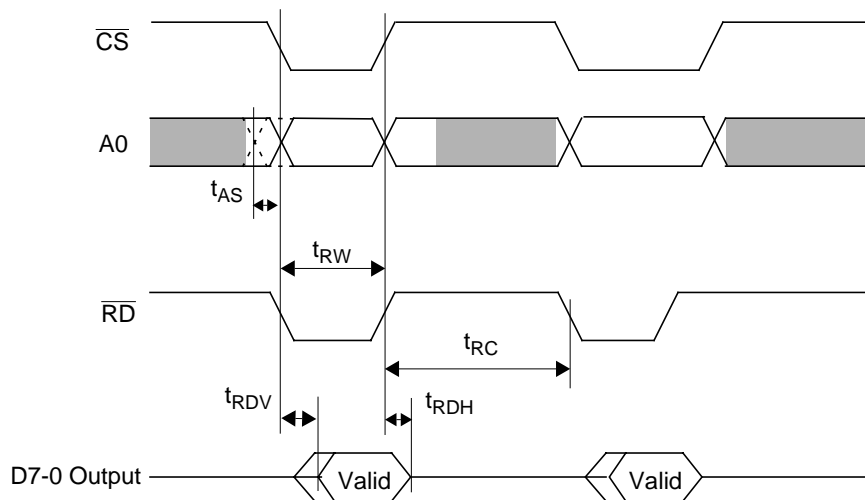

**Figure 25. Non-Multiplexed Mode Read Timing
(Consecutive Read Cycles Shown)**

Note: The setup time t_{AS} is defined relative to the first transition of either \overline{CS} or \overline{RD} . All three signals may switch at the same time.

8.0 Device Characteristics (Continued)

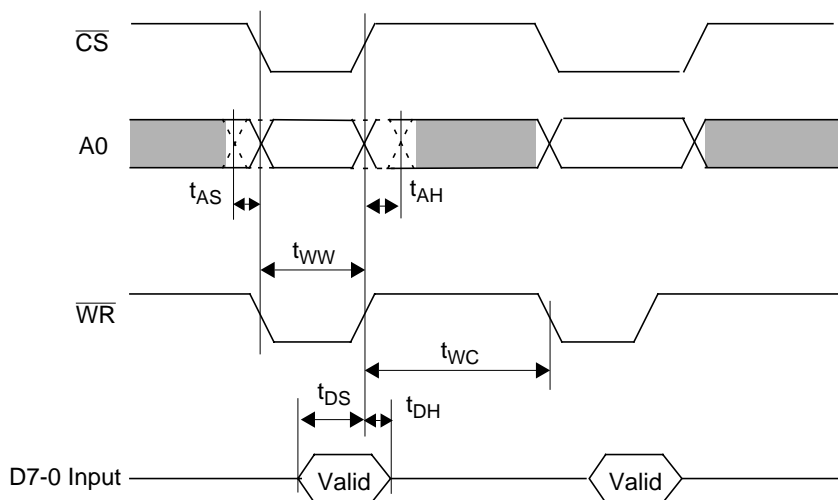

**Figure 26. Non-Multiplexed Mode Write Timing
(Consecutive Write Cycles Shown)**

Note: The setup and hold times t_{AS} and t_{AH} are defined relative to the first transition of either CS or WR. All three signals may switch at the same time.

8.5 PARALLEL INTERFACE TIMING (MODE1-0 = 01_B)

($3.0V < V_{CC} < 5.5V$, $0^{\circ}C < T_A < +70^{\circ}C$, unless otherwise specified)

Symbol	Parameter	Conditions	Min	Typ	Max	Units
t_{AH}	ALE High Time ¹	$C_L = 50 \text{ pF}$	1/CKI			nS
t_{CLAL}	Chip Select Low to ALE Low	$C_L = 50 \text{ pF}$	1/CKI			nS
t_{AVAL}	Address Valid to ALE Low	$C_L = 50 \text{ pF}$	10			nS
t_{AHAL}	Address Hold after ALE Low	$C_L = 50 \text{ pF}$	10			nS
t_{ALRH}	ALE Low to RD High ²	$C_L = 50 \text{ pF}$	3/MCLK			nS
t_{RDLV}	Read Low to Data Valid	$C_L = 50 \text{ pF}$		20	30	nS
t_{RHDZ}	Data Hold after Read High	$C_L = 50 \text{ pF}$	2		15	nS
t_{RL}	Read Pulse Width	$C_L = 50 \text{ pF}$	1/CKI			nS
t_{WHAH}	Write High to next ALE High	$C_L = 50 \text{ pF}$	3/MCLK			nS
t_{WHCH}	Write High to CS High	$C_L = 50 \text{ pF}$	10			nS
t_{WL}	Write Pulse Width	$C_L = 50 \text{ pF}$	1/CKI			nS
t_{DSWH}	Data Setup to WR High	$C_L = 50 \text{ pF}$	25			nS
t_{DHW}	Data Hold after WR High	$C_L = 50 \text{ pF}$	2			nS

1. Clock Internal: CKI = 48 MHz on this device

2. Memory Clock: MCLK = CKI/4 = 12 MHz

8.0 Device Characteristics (Continued)

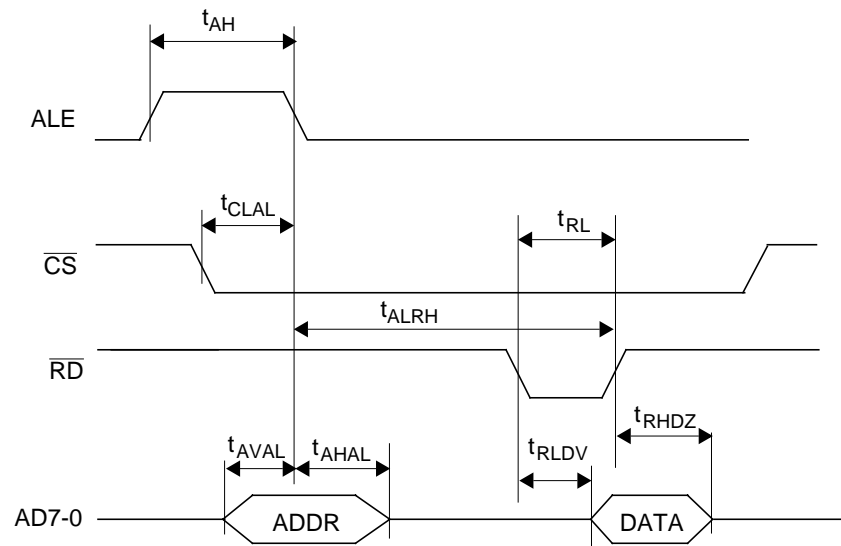

Figure 27. Multiplexed Mode Interface Read Timing

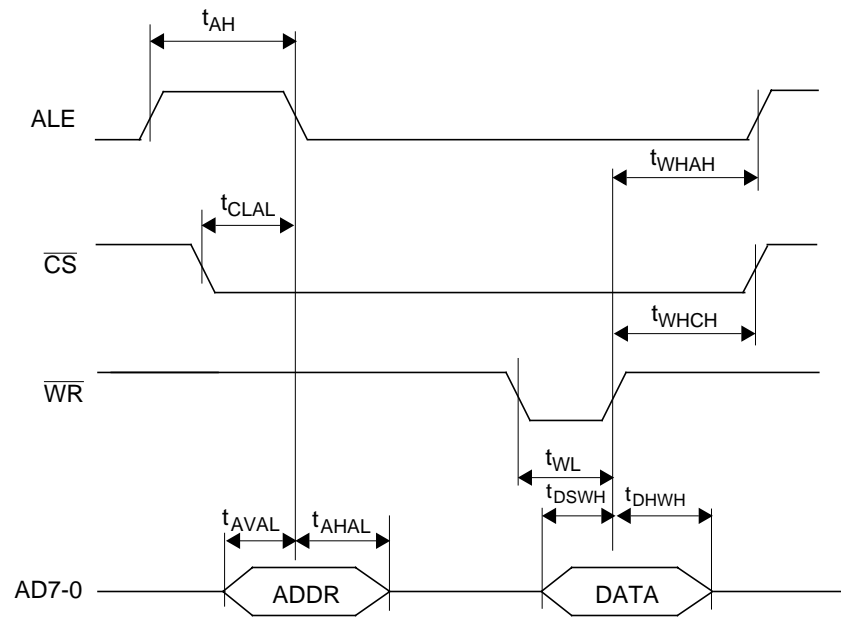

Figure 28. Multiplexed Mode Interface Write Timing

8.0 Device Characteristics (Continued)

8.6 DMA SUPPORT TIMING

($3.0V < V_{CC} < 5.5V$, $0^{\circ}C < T_A < +70^{\circ}C$, unless otherwise specified)

Symbol	Parameter	Conditions	Min	Typ	Max	Units
t_{RHAL}	Request High to ACK Low	$C_L = 50 \text{ pF}$	0			nS
t_{ALWL}	ACK Low to Write Low	$C_L = 50 \text{ pF}$	0			nS
t_{WW}	Write Pulse Width	$C_L = 50 \text{ pF}$	$1/CKI$			nS
t_{WRL}	Write High to Request Low	$C_L = 50 \text{ pF}$			$2/MCLK$	nS
t_{DWR}	DMA Write Recovery ¹	$C_L = 50 \text{ pF}$			$2/MCLK$	nS
t_{ALRL}	ACK low to Read Low	$C_L = 50 \text{ pF}$	0			nS
t_{RW}	Read Pulse Width	$C_L = 50 \text{ pF}$	$1/CKI$			nS
t_{RRL}	Read High to Request Low	$C_L = 50 \text{ pF}$			$2/MCLK$	nS
t_{DRR}	DMA Read Recovery ¹	$C_L = 50 \text{ pF}$			$2/MCLK$	nS

1. If DMA transfer is not interrupted by read or write. If the transfer is interrupted, two additional MCLK cycles are used.

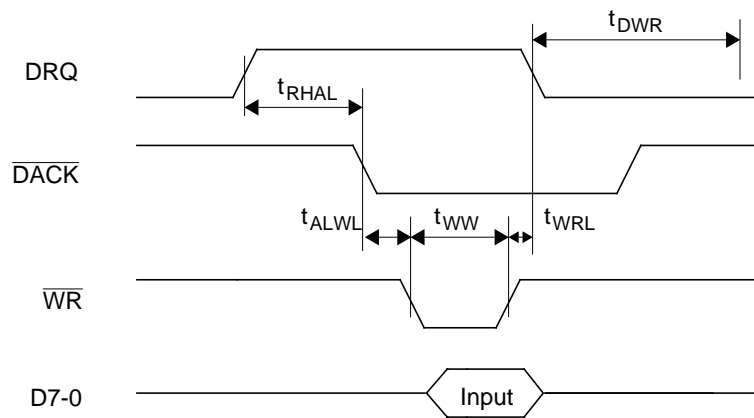

Figure 29. DMA Write to USBN9603/4

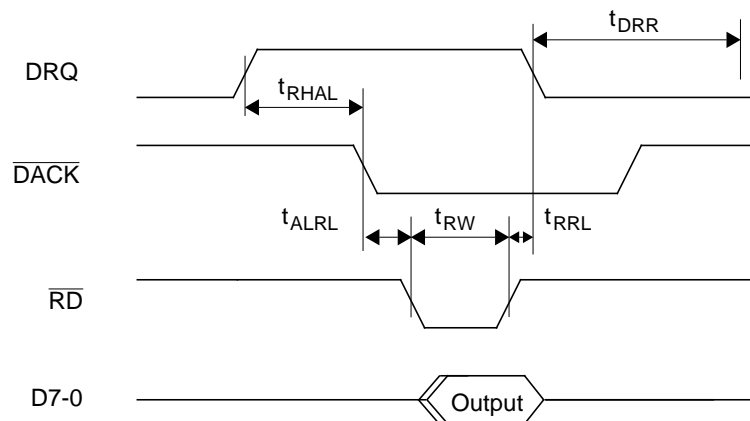

Figure 30. DMA Read from USBN9603/4

8.0 Device Characteristics (Continued)

8.7 MICROWIRE INTERFACE TIMING (MODE1-0 = 10_B)

Symbol	Parameter	Condition	Min	Typ	Max	Units
t_{SKC}	SK Cycle Time ¹	$C_L = 50 \text{ pF}$	4/MCLK			nS
t_{CC}	Time between two consecutive 8 clock cycles ¹	$C_L = 50 \text{ pF}$	4/MCLK			nS
t_{SIH}	Serial Input Hold Time	$C_L = 50 \text{ pF}$	3/MCLK			nS
t_{SOV}	Serial Output Valid Time	$C_L = 50 \text{ pF}$			3/MCLK	nS

1. Memory Clock: MCLK = CKI/4 = 12 MHz

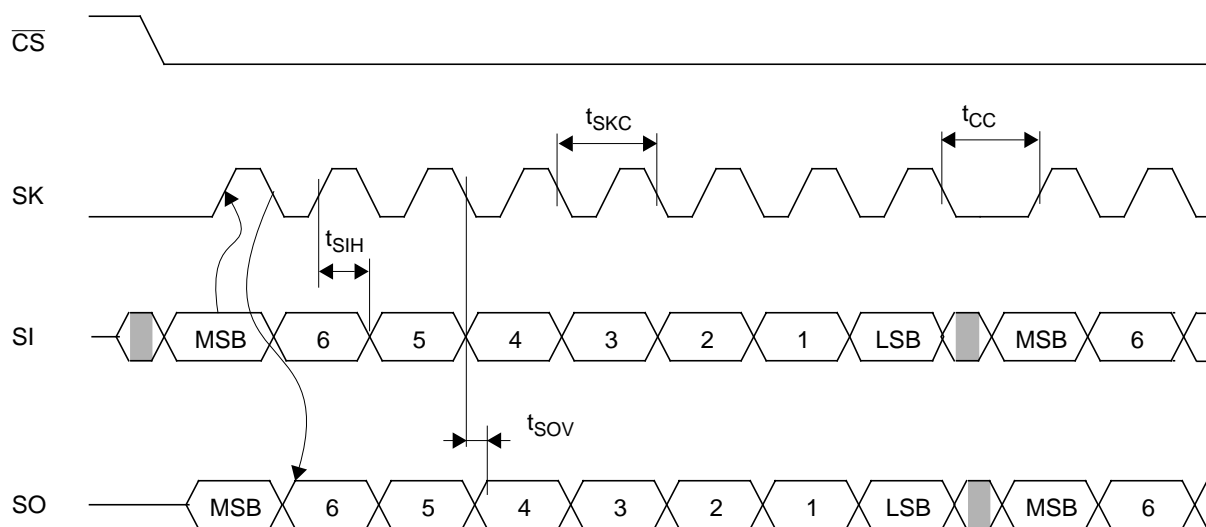

Note: The first eight SKs shift out the current contents of the Shift register.

Figure 31. MICROWIRE Interface Timing

Physical Dimensions

inches (millimeters) unless otherwise noted

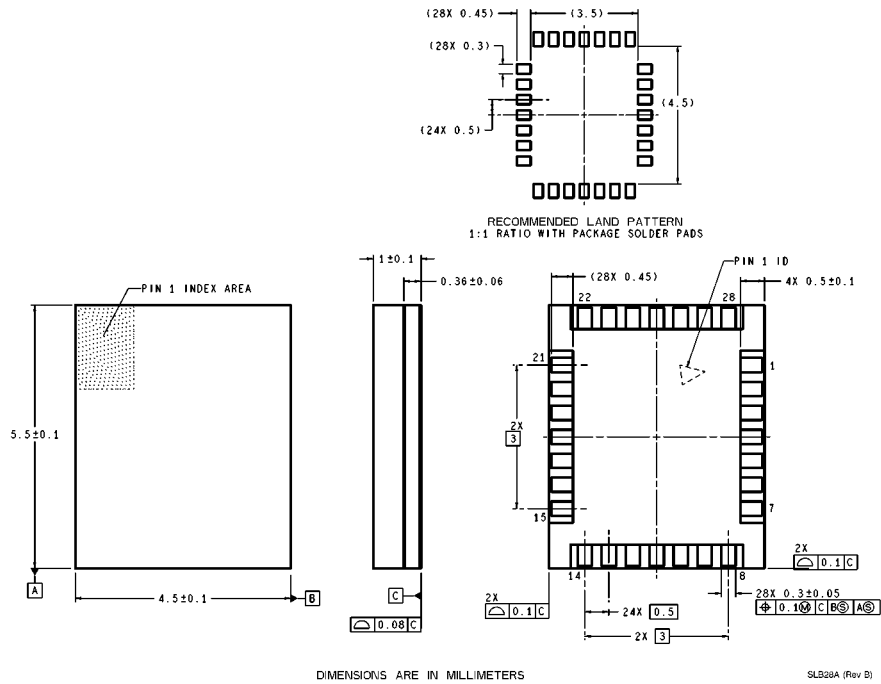

Laminate Substrate Based Package
Order Number USBN9603/4SLB
See NS Package Number SLB28AA

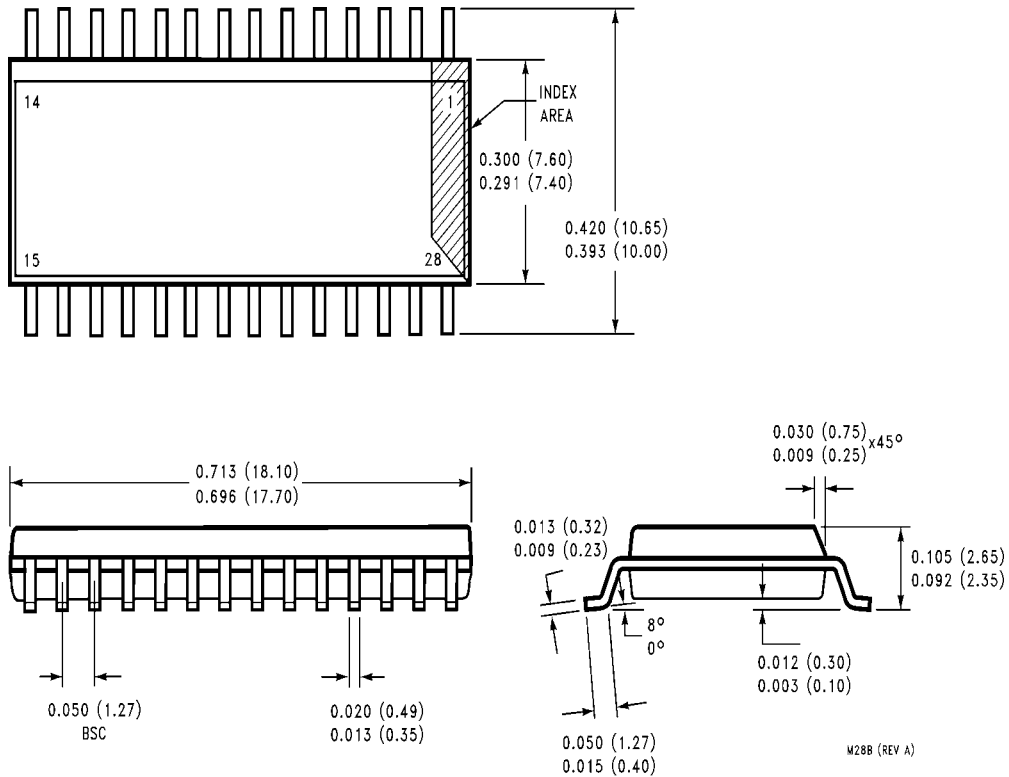

Molded SO Wide Body Package (WM)
Order Number USBN9603/4-28M
See NS Package Number M28B

LIFE SUPPORT POLICY

NATIONAL'S PRODUCTS ARE NOT AUTHORIZED FOR USE AS CRITICAL COMPONENTS IN LIFE SUPPORT DEVICES OR SYSTEMS WITHOUT THE EXPRESS WRITTEN APPROVAL OF THE PRESIDENT AND GENERAL COUNCIL OF NATIONAL SEMICONDUCTOR CORPORATION. As used herein:

1. Life support devices or systems are devices or systems which, (a) are intended for surgical implant into the body, or (b) support or sustain life, and whose failure to perform, when properly used in accordance with instructions for use provided in the labeling, can be reasonably expected to result in a significant injury to the user.
2. A critical component is any component of a life support device or system whose failure to perform can be reasonably expected to cause the failure of the life support device or system, or to affect its safety or effectiveness.



National Semiconductor Corporation, Americas
Tel: 1-800-272-9959
Fax: 1-800-737-7018
Email: support@nsc.com

National Semiconductor Europe
Fax: +49 (0) 1 80-530 85 86
Email: europe.support@nsc.com
Deutsch Tel: +49 (0) 69 9508 6208
English Tel: +44 (0) 870 24 0 2171
Français Tel: +33 (0) 1 41 91 8790

National Semiconductor Asia Pacific
Tel: 65-2544466
Fax: 65-2504466
Email: ap.support@nsc.com

National Semiconductor Japan Ltd.
Tel: 81-3-5639-7560
Fax: 81-3-5639-7507
Email: nsj.crc@jksmtp.nsc.com