



**5V/3.3V 128Kx8 CMOS SRAM (Revolutionary pinout)**

**Features**

- AS7C1025 (5V version)
- AS7C31025 (3.3V version)
- Industrial and commercial temperatures
- Organization: 131,072 words × 8 bits
- High speed
  - 12/15/20 ns address access time
  - 3/4/5 ns output enable access time
- Low power consumption: ACTIVE
  - 715 mW (AS7C1025) / max @ 12 ns (5V)
  - 360 mW (AS7C31025) / max @ 12 ns (3.3V)

- Low power consumption: STANDBY
  - 27.5 mW (AS7C1025) / max CMOS (5V)
  - 1.8 mW (AS7C31025) / max CMOS (3.3V)
- 2.0V data retention
- Easy memory expansion with  $\overline{CE}$ ,  $\overline{OE}$  inputs
- Center power and ground
- TTL/LVTTL-compatible, three-state I/O
- JEDEC-standard packages
  - 32-pin, 300 mil SOJ
  - 32-pin, 400 mil SOJ
  - 32-pin TSOP II
- ESD protection  $\geq 2000$  volts
- Latch-up current  $\geq 200$  mA

**Logic block diagram**

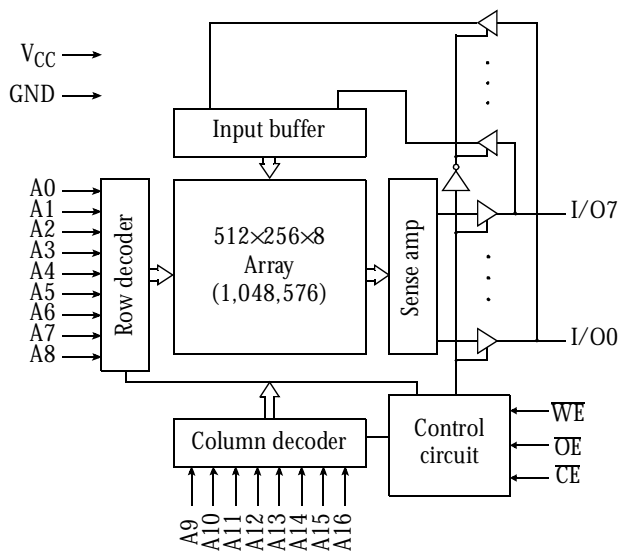

**Pin arrangement**

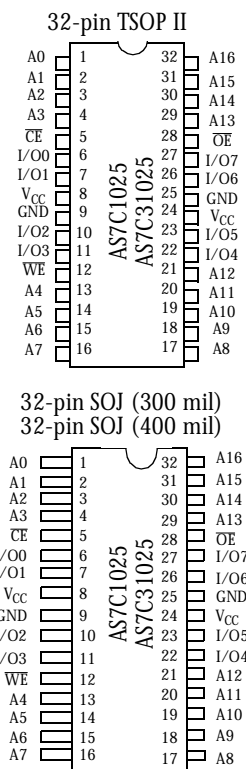

**Selection guide**

		AS7C1025-12 AS7C31025-12	AS7C1025-15 AS7C31025-15	AS7C1025-20 AS7C31025-20	Unit
Maximum address access time		12	15	20	ns
Maximum output enable access time		3	4	5	ns
Maximum operating current	AS7C1025	130	85	80	mA
	AS7C31025	100	85	80	mA
Maximum CMOS standby current	AS7C1025	5	5	5	mA
	AS7C31025	5	5	5	mA

Shaded areas contain advance information.



## Functional description

The AS7C1025 and AS7C31025 are high-performance CMOS 1,048,576-bit Static Random Access Memory (SRAM) devices organized as 131,072 words  $\times$  8 bits. They are designed for memory applications where fast data access, low power, and simple interfacing are desired.

Equal address access and cycle times ( $t_{AA}$ ,  $t_{RC}$ ,  $t_{WC}$ ) of 12/15/20 ns with output enable access times ( $t_{OE}$ ) of 3/4/5 ns are ideal for high-performance applications. The chip enable input  $\overline{CE}$  permits easy memory and expansion with multiple-bank memory systems.

When  $\overline{CE}$  is high the devices enter standby mode. The standard AS7C1025 is guaranteed not to exceed 27.5 mW power consumption in standby mode, and typically requires only 5 mW. Both devices also offer 2.0V data retention.

A write cycle is accomplished by asserting write enable ( $\overline{WE}$ ) and chip enable ( $\overline{CE}$ ). Data on the input pins I/O0-I/O7 is written on the rising edge of  $\overline{WE}$  (write cycle 1) or  $\overline{CE}$  (write cycle 2). To avoid bus contention, external devices should drive I/O pins only after outputs have been disabled with  $\overline{OE}$  ( $\overline{WE}$ ).

A read cycle is accomplished by asserting output enable ( $\overline{OE}$ ) and chip enable ( $\overline{CE}$ ), with write enable ( $\overline{WE}$ ) high. The chips drive I/O pins with the data word referenced by the input address. When either chip enable or output enable is inactive, or write enable is active, output drivers stay in high-impedance mode.

All chip inputs and outputs are TTL-compatible, and operation is from a single 5V supply (AS7C1025) or 3.3V supply (AS7C31025). The AS7C1025 and AS7C31025 are packaged in common industry standard packages.

## Absolute maximum ratings

Parameter	Device	Symbol	Min	Max	Unit
Voltage on $V_{CC}$ relative to GND	AS7C1025	$V_{t1}$	-0.50	+7.0	V
	AS7C31025	$V_{t1}$	-0.50	+5.0	V
Voltage on any pin relative to GND		$V_{t2}$	-0.50	$V_{CC} + 0.5$	V
Power dissipation		$P_D$	-	1.0	W
Storage temperature (plastic)		$T_{stg}$	-65	+150	$^{\circ}C$
Ambient temperature with $V_{CC}$ applied		$T_{bias}$	-55	+125	$^{\circ}C$
DC current into outputs (low)		$I_{OUT}$	-	20	mA

NOTE: Stresses greater than those listed under Absolute Maximum Ratings may cause permanent damage to the device. This is a stress rating only and functional operation of the device at these or any other conditions outside those indicated in the operational sections of this specification is not implied. Exposure to absolute maximum rating conditions for extended periods may affect reliability.

## Truth table

$\overline{CE}$	$\overline{WE}$	$\overline{OE}$	Data	Mode
H	X	X	High Z	Standby ( $I_{SB}$ , $I_{SB1}$ )
L	H	H	High Z	Output disable ( $I_{CC}$ )
L	H	L	$D_{OUT}$	Read ( $I_{CC}$ )
L	L	X	$D_{IN}$	Write ( $I_{CC}$ )

Key: X = Don't Care, L = Low, H = High



**Recommended operating conditions**

Parameter	Device	Symbol	Min	Nominal	Max	Unit
Supply voltage	AS7C1025	$V_{CC}$	4.5	5.0	5.5	V
	AS7C31025	$V_{CC}$	3.0	3.3	3.6	V
Input voltage	AS7C1025	$V_{IH}$	2.2	-	$V_{CC} + 0.5$	V
	AS7C31025	$V_{IH}$	2.0	-	$V_{CC} + 0.5$	V
		$V_{IL}^{\dagger}$	-0.5	-	0.8	V
Ambient operating temperature	commercial	$T_A$	0	-	70	°C
	industrial	$T_A$	-40	-	85	°C

<sup>†</sup> $V_{IL}$  min = -3.0V for pulse width less than  $t_{RC}/2$ .

**DC operating characteristics (over the operating range)**

Parameter	Sym	Test conditions	Device	-12		-15		-20		Unit
				Min	Max	Min	Max	Min	Max	
Input leakage current	$ I_{LI} $	$V_{CC} = \text{Max}, V_{IN} = \text{GND to } V_{CC}$		-	1	-	1	-	1	$\mu\text{A}$
Output leakage current	$ I_{LO} $	$V_{CC} = \text{Max}, \overline{CE} = V_{IH}, V_{out} = \text{GND to } V_{CC}$		-	1	-	1	-	1	$\mu\text{A}$
Operating power supply current	$I_{CC}$	$\overline{CE} = V_{IL}, f = f_{\text{Max}}, I_{OUT} = 0 \text{ mA}$	AS7C1025	-	130	-	120	-	110	mA
			AS7C31025	-	100	-	85	-	80	
Standby power supply current	$I_{SB}$	$\overline{CE} = V_{IH}, f = f_{\text{Max}}, f_{OUT} = 0$	AS7C1025	-	50	-	40	-	40	mA
			AS7C31025	-	50	-	40	-	40	
Standby power supply current	$I_{SB1}$	$\overline{CE} \geq V_{CC} - 0.2\text{V}, V_{IN} \leq 0.2\text{V}$ or $V_{IN} \geq V_{CC} - 0.2\text{V}, f = 0, f_{OUT} = 0$	AS7C1025	-	5	-	5	-	5	mA
			AS7C31025	-	5	-	5	-	5	
Output voltage	$V_{OL}$	$I_{OL} = 8 \text{ mA}, V_{CC} = \text{Min}$		-	0.4	-	0.4	-	0.4	V
	$V_{OH}$	$I_{OH} = -4 \text{ mA}, V_{CC} = \text{Min}$		2.4	-	2.4	-	2.4	-	V

Shaded areas contain advance information.

**Capacitance ( $f = 1 \text{ MHz}, T_a = 25 \text{ }^\circ\text{C}, V_{CC} = \text{NOMINAL}$ )**

Parameter	Symbol	Signals	Test conditions	Max	Unit
Input capacitance	$C_{IN}$	A, $\overline{CE}$ , WE, OE	$V_{IN} = 0\text{V}$	5	pF
I/O capacitance	$C_{I/O}$	I/O	$V_{IN} = V_{OUT} = 0\text{V}$	7	pF



Read cycle (over the operating range)

Parameter	Symbol	-12		-15		-20		Unit	Notes
		Min	Max	Min	Max	Min	Max		
Read cycle time	$t_{RC}$	12	-	15	-	20	-	ns	
Address access time	$t_{AA}$	-	12	-	15	-	20	ns	3
Chip enable ( $\overline{CE}$ ) access time	$t_{ACE}$	-	12	-	15	-	20	ns	3
Output enable ( $\overline{OE}$ ) access time	$t_{OE}$	-	3	-	4	-	5	ns	
Output hold from address change	$t_{OH}$	3	-	3	-	3	-	ns	5
$\overline{CE}$ to output in low Z	$t_{CLZ}$	0	-	0	-	0	-	ns	4, 5
$\overline{CE}$ Low to output in high Z	$t_{CHZ}$	-	3	-	4	-	5	ns	4, 5
$\overline{OE}$ Low to output in low Z	$t_{OLZ}$	0	-	0	-	0	-	ns	4, 5
$\overline{OE}$ High to output in high Z	$t_{OHZ}$	-	3	-	4	-	5	ns	4, 5
Power up time	$t_{PU}$	0	-	0	-	0	-	ns	4, 5
Power down time	$t_{PD}$	-	12	-	15	-	20	ns	4, 5

Key to switching waveforms



Read waveform 1 (address controlled)

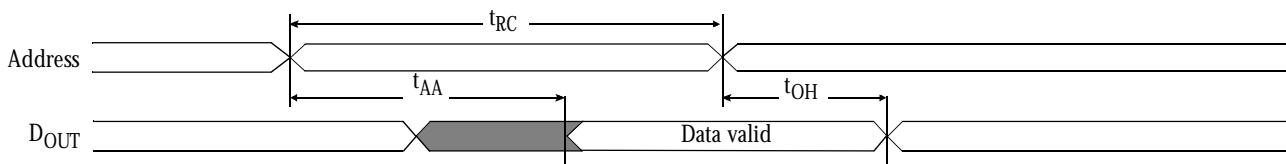

Read waveform 2 ( $\overline{CE}$  and  $\overline{OE}$  controlled)

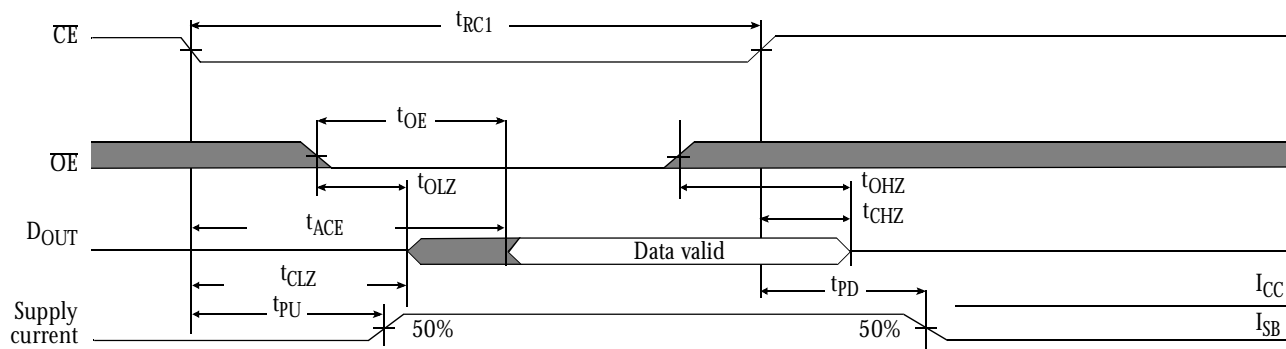



Write cycle (over the operating range)

Parameter	Symbol	-12		-15		-20		Unit	Notes
		Min	Max	Min	Max	Min	Max		
Write cycle time	$t_{WC}$	12	–	15	–	20	–	ns	
Chip enable ( $\overline{CE}$ ) to write end	$t_{CW}$	8	–	12	–	12	–	ns	
Address setup to write end	$t_{AW}$	8	–	12	–	12	–	ns	
Address setup time	$t_{AS}$	0	–	0	–	0	–	ns	
Write pulse width	$t_{WP}$	8	–	9	–	12	–	ns	
Address hold from end of write	$t_{AH}$	0	–	0	–	0	–	ns	
Data valid to write end	$t_{DW}$	6	–	8	–	12	–	ns	
Data hold time	$t_{DH}$	0	–	0	–	0	–	ns	4, 5
Write enable to output in high Z	$t_{WZ}$	–	5	–	5	–	5	ns	4, 5
Output active from write end	$t_{OW}$	3	–	3	–	3	–	ns	4, 5

Shaded areas contain advance information.

Write waveform 1 ( $\overline{WE}$  controlled)

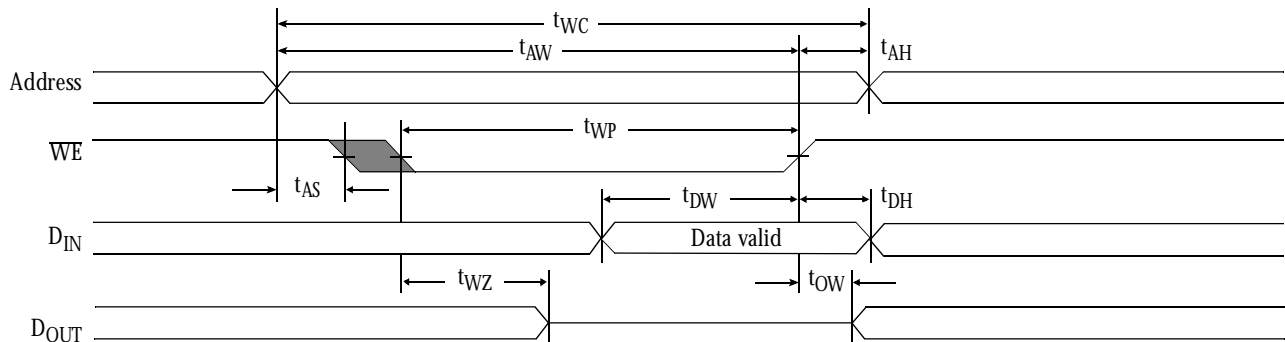

Write waveform 2 ( $\overline{CE}$  controlled)

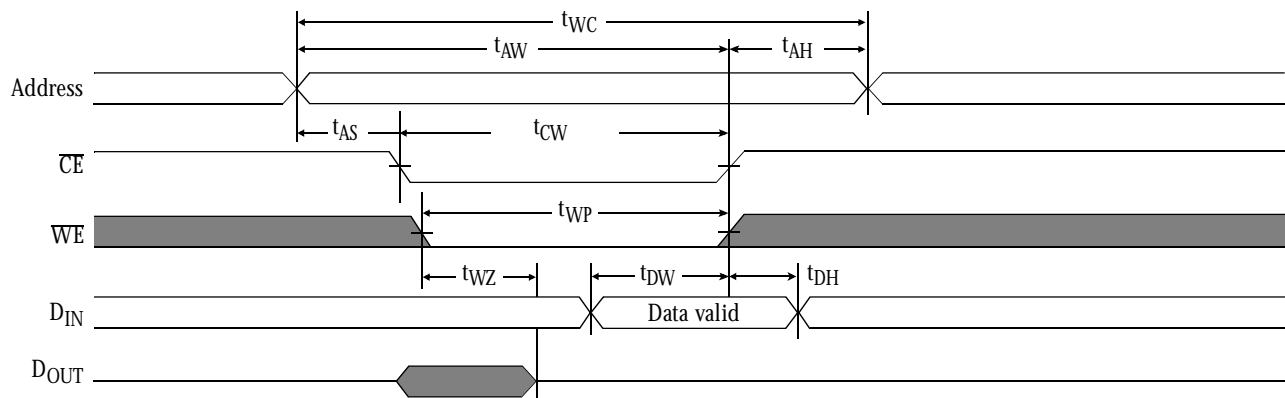



**Data retention characteristics (over the operating range)**

Parameter	Symbol	Test conditions	Min	Max	Unit
$V_{CC}$ for data retention	$V_{DR}$	$V_{CC} = 2.0V$ $\overline{CE} \geq V_{CC} - 0.2V$ $V_{IN} \geq V_{CC} - 0.2V$ or $V_{IN} \leq 0.2V$	2.0	-	V
Data retention current	$I_{CCDR}$		-	500	$\mu A$
Chip enable to data retention time	$t_{CDR}$		0	-	ns
Operation recovery time	$t_R$		$t_{RC}$	-	ns
Input leakage current	$ I_{LI} $		-	1	$\mu A$

**Data retention waveform**

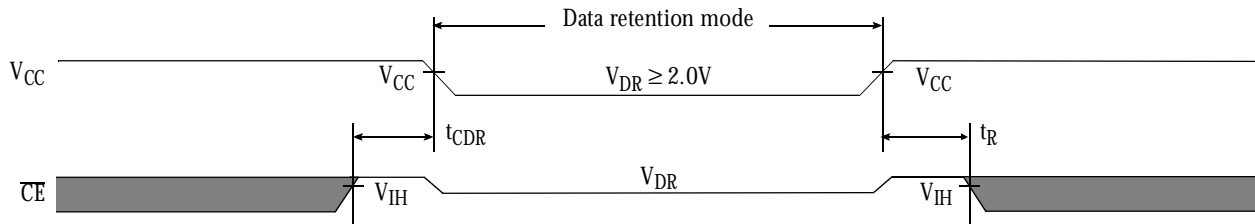

**AC test conditions**

- 5V output load: see Figure B or Figure C.
- Input pulse level: GND to 3.0V. See Figure A.
- Input rise and fall times: 2 ns. See Figure A.
- Input and output timing reference levels: 1.5V.

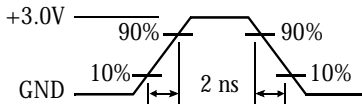

Figure A: Input pulse

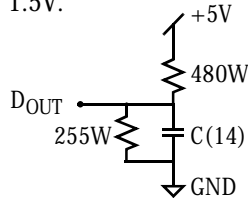

Figure B: 5V Output load

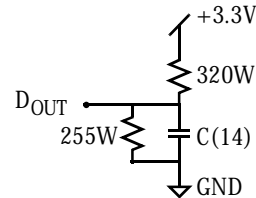
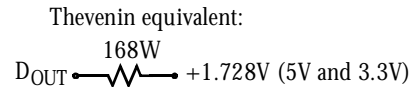

Figure C: 3.3V Output load

**Notes**

- 1 During  $V_{CC}$  power-up, a pull-up resistor to  $V_{CC}$  on  $\overline{CE}$  is required to meet  $I_{SB}$  specification.
- 2 This parameter is sampled, but not 100% tested.
- 3 For test conditions, see AC Test Conditions, Figures A, B, and C.
- 4  $t_{CLZ}$  and  $t_{CHZ}$  are specified with  $CL = 5pF$ , as in Figure C. Transition is measured  $\pm 500mV$  from steady-state voltage.
- 5 This parameter is guaranteed, but not 100% tested.
- 6  $\overline{WE}$  is High for read cycle.
- 7  $\overline{CE}$  and  $\overline{OE}$  are Low for read cycle.
- 8 Address valid prior to or coincident with  $\overline{CE}$  transition Low.
- 9 All read cycle timings are referenced from the last valid address to the first transitioning address.
- 10  $\overline{CE}$  or  $\overline{WE}$  must be High during address transitions. Either  $\overline{CE}$  or  $\overline{WE}$  asserting high terminates a write cycle.
- 11 All write cycle timings are referenced from the last valid address to the first transitioning address.
- 12 NA.
- 13 2V data retention applies to commercial temperature operating range only.
- 14  $C = 30pF$ , except all high Z and low Z parameters, where  $C = 5pF$ .



Typical DC and AC characteristics

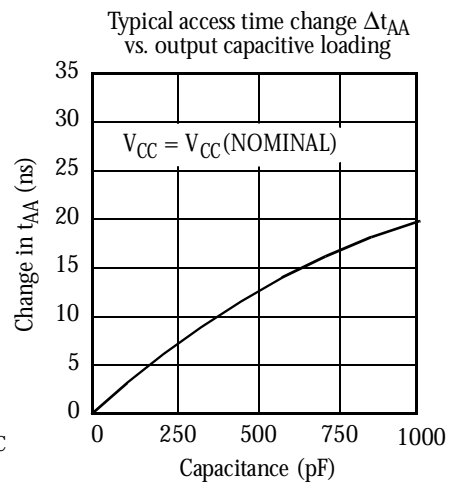
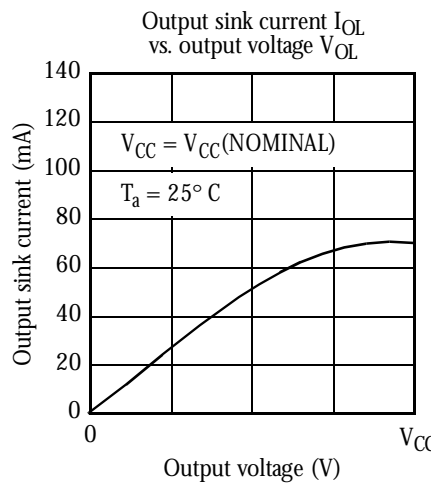
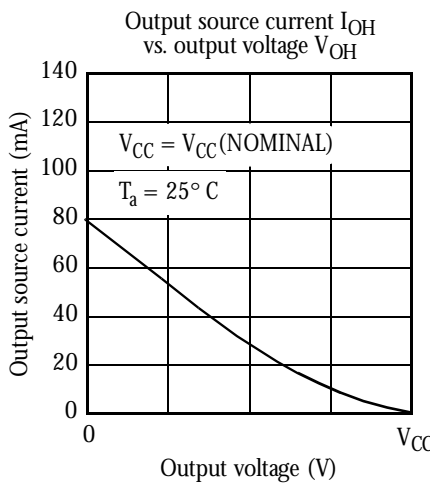
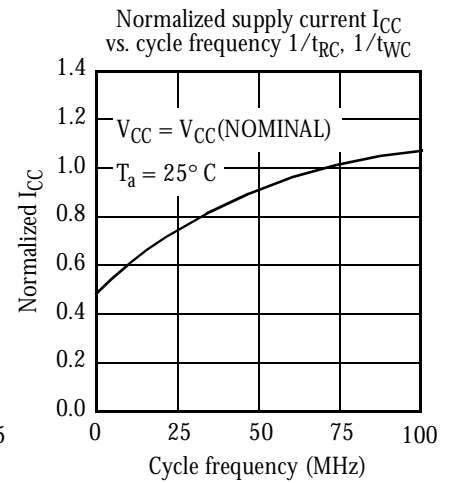
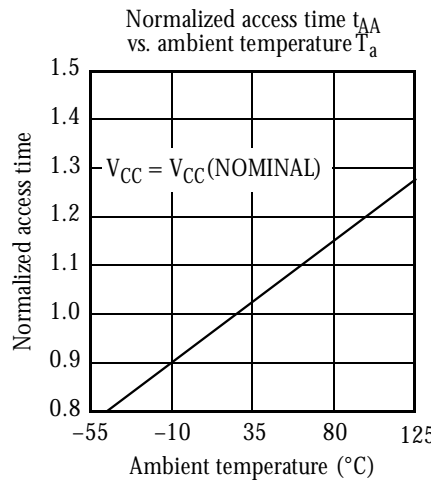
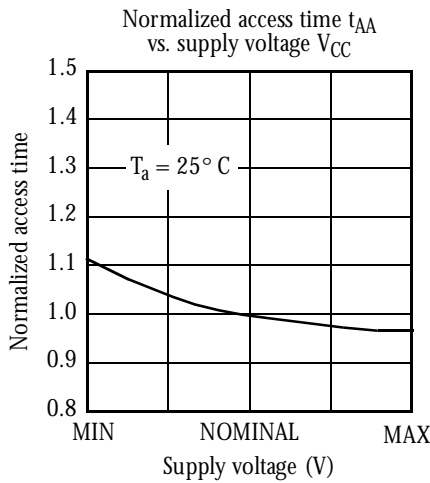
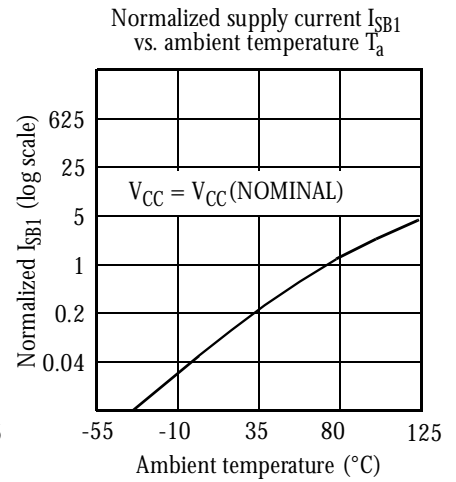
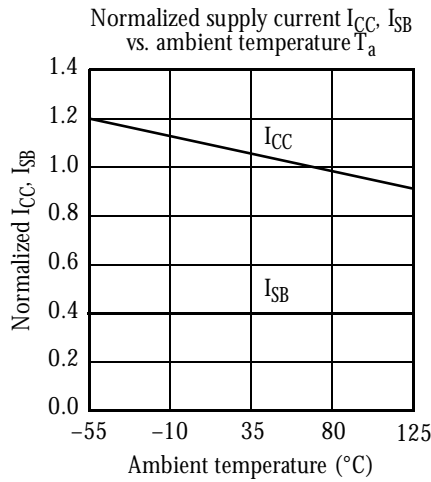
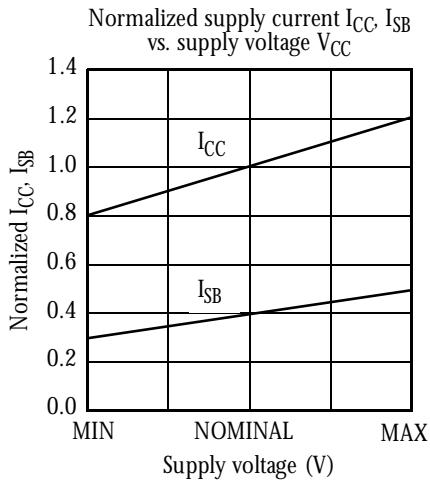



Package dimensions

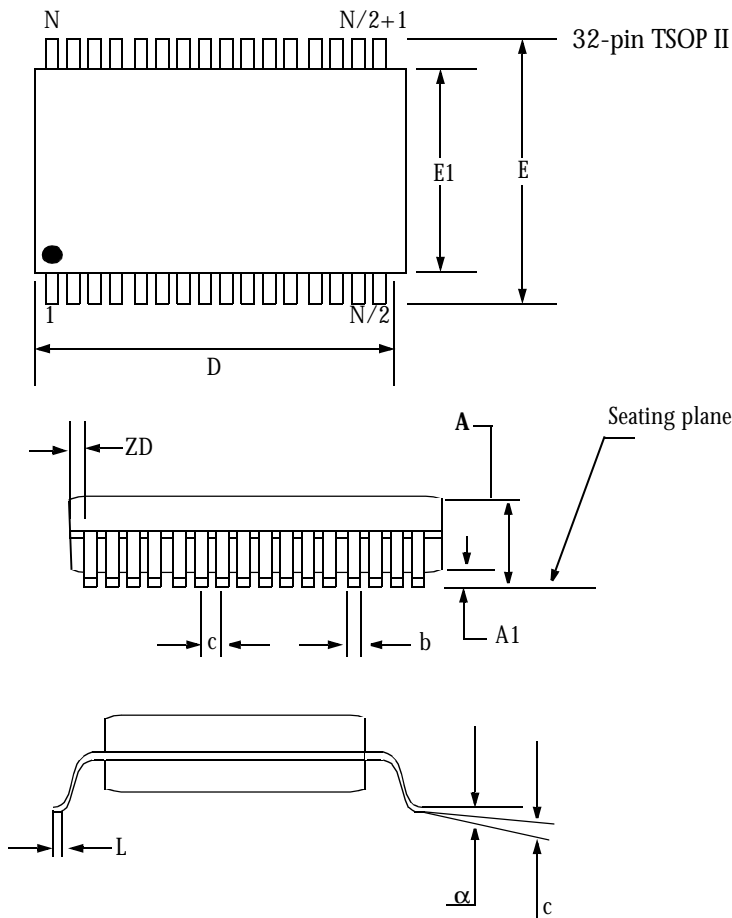

Symbol	32-pin TSOP II (mil)	
	Min	Max
A	-	1.2
A1	0.05	0.15
b	0.3	0.52
C	0.12	0.21
D	20.82	21.08
E1	10.03	10.29
E	11.56	11.96
e	1.27 BSC	
L	0.40	0.60
ZD	0.95 REF.	
$\alpha$	0°	5°

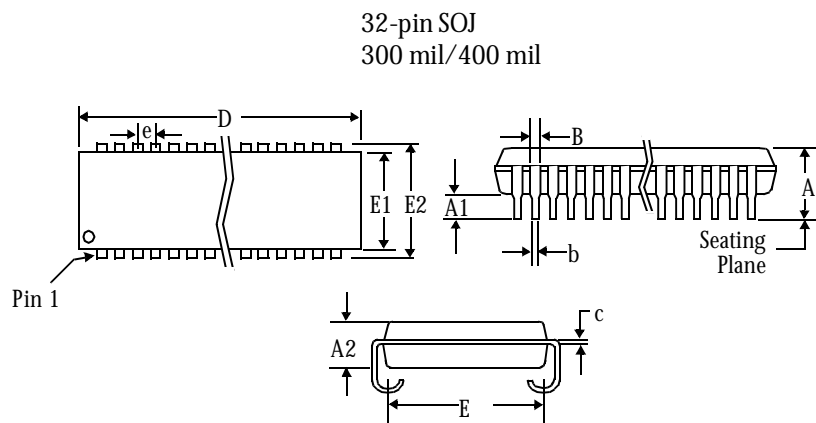

Symbol	32-pin SOJ 300 mil		32-pin SOJ 400 mil	
	Min	Max	Min	Max
A	-	0.145	-	0.145
A1	0.025	-	0.025	-
A2	0.086	0.105	0.086	0.115
B	0.026	0.032	0.026	0.032
b	0.014	0.020	0.015	0.020
c	0.006	0.013	0.007	0.013
D	0.820	0.830	0.820	0.830
E	0.250	0.275	0.360	0.380
E1	0.292	0.305	0.395	0.405
E2	0.330	0.340	0.435	0.445



## Ordering codes

Package \ Access time	Voltage	Temperature	12 ns	15 ns	20 ns
sTSOP II	5V	Commercial	AS7C1025-12TC	AS7C1025-15TC	AS7C1025-20TC
		Industrial	AS7C1025-12TI	AS7C1025-15TI	AS7C1025-20TI
	3.3V	Commercial	AS7C31025-12TC	AS7C31025-15TC	AS7C31025-20TC
		Industrial	AS7C31025-12TI	AS7C31025-15TI	AS7C31025-20TI
300-mil SOJ	5V	Commercial	AS7C1025-12TJC	AS7C1025-15TJC	AS7C1025-20TJC
		Industrial	AS7C1025-12TJI	AS7C1025-15TJI	AS7C1025-20TJI
	3.3V	Commercial	AS7C31025-12TJC	AS7C31025-15TJC	AS7C31025-20TJC
		Industrial	AS7C31025-12TJI	AS7C31025-15TJI	AS7C31025-20TJI
400-mil SOJ	5V	Commercial	AS7C1025-12JC	AS7C1025-15JC	AS7C1025-20JC
		Industrial	AS7C1025-12JI	AS7C1025-15JI	AS7C1025-20JI
	3.3V	Commercial	AS7C31025-12JC	AS7C31025-15JC	AS7C31025-20JC
		Industrial	AS7C31025-12JI	AS7C31025-15JI	AS7C31025-20JI

## Part numbering system

AS7C	X	1025	-XX	X	X
SRAM prefix	Blank=5V CMOS 3=3.3V CMOS	Device number	Access time	Package: T = TSOP II J = SOJ	Temperature range C = Commercial, 0°C to 70°C I = Industrial, -40°C to 85°C